

Front Suspension:

Camber: _____ °
Total Toe: _____ °
Ride Height: _____
Arm Type: _____
Tower Type: _____
Caster Block Insert: _____ °
Kick-Up Angle: _____ °
Wheel Hex: _____

Notes:

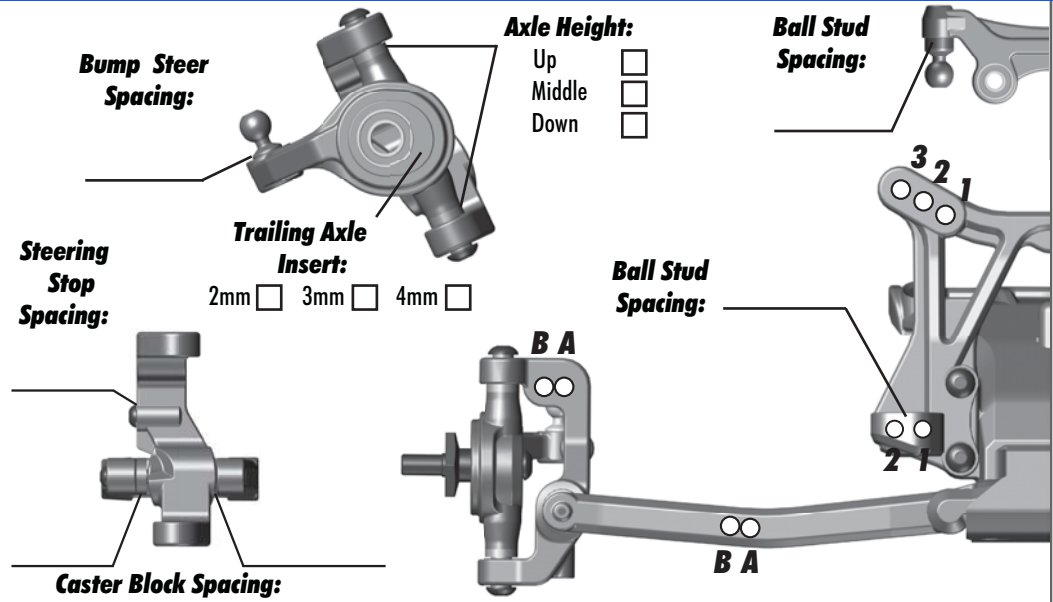

Rear Suspension:

Camber: _____ °
Ride Height: _____
Wheel Hex: _____
Hub Spacing: Forward Middle Back

Notes:

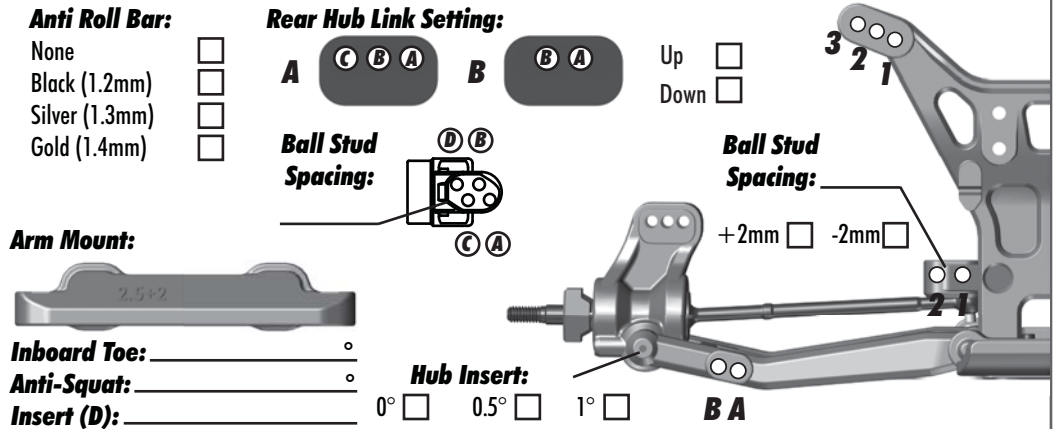

Electronics:

Radio: _____ **Servo:** _____
EPA: Throttle: _____ % **Brake:** _____ %
ESC: _____
ESC Settings: _____
Motor: _____
Wind: _____ **Timing:** _____
Pinion: _____ **Spur:** _____
Battery: _____
Battery Position: _____

Drivetrain:

Differential: Ball Gear
Gearbox: 3 Gears 4 Gears
Notes: _____

Slipper Clutch:

Type: _____
of Pads: _____
Notes: _____

Shocks:

	Front	Rear
Piston:		
Oil:		
Spring:		
Limiters:		
Cup Offset:		
Stroke:		
Free Length:		
Notes:		

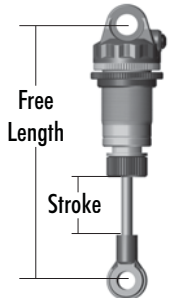

Track Info:

Size: Small Medium Large Extra Large
Surfaces: Dirt Carpet AstroTurf Multi Surface
Traction: Low Medium High Very High
Moisture: Dry Damp Wet
Condition: Indoor Outdoor Dusty Hard Packed
 Bumpy Grooved Smooth Loamy

Temperature: Ambient: _____ Track: _____

Notes:

Tires:

_____ :F - Tires - R:
 _____ :F - Compound - R:
 _____ :F - Insert - R:
 _____ :F - Wheel - R:
 _____ :F - Notes - R:

Body & Wing:

Body: _____
Wing: _____
Wing Angle: 0° 3° 6°
Notes: _____

Race Results:

Qualify: _____ **Main:** _____
Finish: _____ **TQ:**
Best Lap Time: _____

Vehicle Comments:

Total Vehicle Weight: _____