

Front Suspension:

- Camber:** _____ °
- Total Toe:** _____ °
- Ride Height:** _____
- Arm Type:** _____
- Tower Type:** _____
- Caster Block Insert:** _____ °
- Kick-Up Angle:** _____ °

Notes:

Bump Steer Spacing:



Trailing Axle Insert:
2mm 3mm 4mm

Axle Height:
Up
Middle
Down

Ball Stud Spacing:



Steering Stop Spacing:

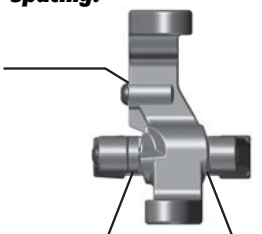

Ball Stud Spacing:

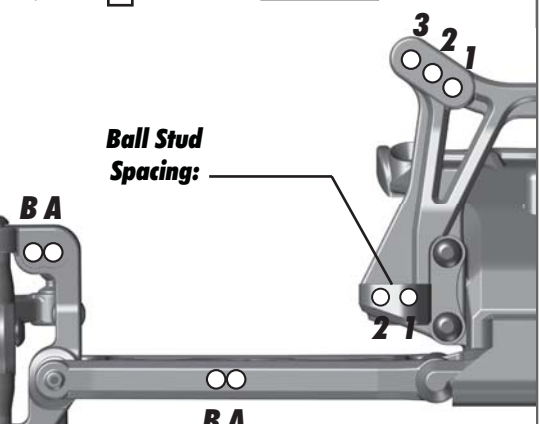

Caster Block Spacing:



Rear Suspension:

- Camber:** _____ °
- Ride Height:** _____
- Hub Spacing:**
Forward Middle Back

Notes:

Anti Roll Bar:
None
Black (1.2mm)
Silver (1.3mm)
Gold (1.4mm)

Rear Hub Link Setting:



Ball Stud Spacing:

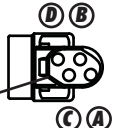

Up
Down

Arm Mount:



Hub Insert:
0° 0.5° 1°

Ball Stud Spacing:

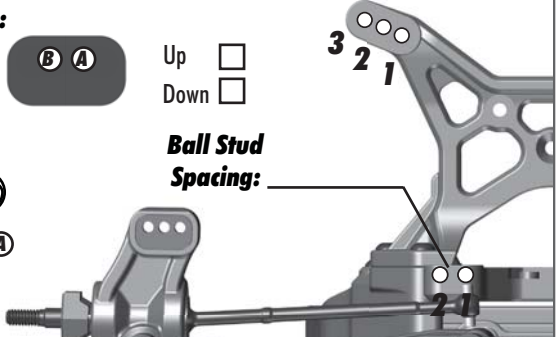

Inboard Toe: _____ °

Anti-Squat: _____ °

Electronics:

- Radio:** _____ **Servo:** _____
- EPA: Throttle:** _____ % **Brake:** _____ %
- ESC:** _____
- ESC Settings:** _____
- Motor:** _____
- Wind:** _____ **Timing:** _____
- Pinion:** _____ **Spur:** _____
- Battery:** _____
- Battery Position:** _____

Drivetrain:

- Differential:**
Ball:
Setting: _____
Gear:
Oil: _____
- Slipper Clutch:**
Type: _____
of Pads: _____
Notes: _____

Shocks:

	Front	Rear
Piston:		
Oil:		
Spring:		
Limiters:		
Cup Offset:		
Stroke:		
Free Length:		
Notes:		



Track Info:

- Size:** Small Medium Large Extra Large
- Surfaces:** Dirt Carpet AstroTurf Multi Surface
- Traction:** Low Medium High Very High
- Moisture:** Dry Damp Wet
- Condition:** Indoor Outdoor Dusty Hard Packed
Bumpy Grooved Smooth Loamy

Temperature: Ambient: _____ Track: _____

Notes:

Tires:

- _____ **:F - Tires - R:** _____
- _____ **:F - Compound - R:** _____
- _____ **:F - Insert - R:** _____
- _____ **:F - Wheel - R:** _____
- _____ **:F - Notes - R:** _____

Body & Wing:

- Body:** _____
- Wing:** _____
- Wing Angle:** 0° 3° 6°
- Notes:** _____

Race Results:

- Quality:** _____ **Main:** _____
- Finish:** _____ **TQ:**
- Best Lap Time:** _____

Vehicle Comments:

Total Vehicle Weight: _____