

Front Suspension:

Ride Height:
Camber:
Toe:
Anti-Roll Bar:
Wheelbase Shim:
Wheel Hex:
Caster Block:
7° <input type="checkbox"/> 10° <input type="checkbox"/> 13° <input type="checkbox"/>
Notes:

Axle Height:

+3

+2

+1

0

Arm Mount A:

LRC HRC 1° 0.5°



Arm Mount B:

LRC HRC 1° 0.5°

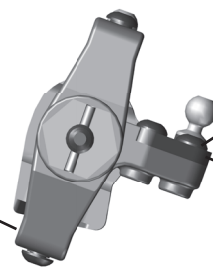

Bump Steer Spacing:

Ball Stud Spacing:

Steering Plate:

Ball Stud Spacing:

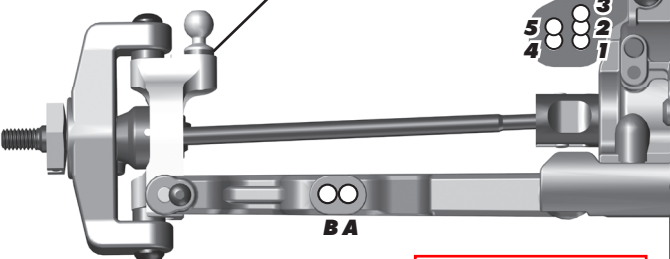

V2 RACK

Rear Suspension:

Ride Height:
Camber:
Anti-Roll Bar:
Wheelbase Shim:
Wheel Hex:
Hub Spacing:
Forward <input type="checkbox"/> Middle <input type="checkbox"/> Back <input type="checkbox"/>
Gearbox Shim: Yes <input type="checkbox"/> No <input type="checkbox"/>
Chassis Brace: Short <input type="checkbox"/> Long <input type="checkbox"/>
Notes:

Arm Mount C:

LRC HRC 1° 0.5°



Arm Mount D:

LRC HRC 1° 0.5°



Rear Hub Link Setting:

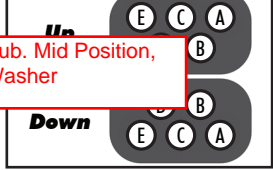

Alloy Hub, Mid Position, 3mm Washer

Rear Shock Mount Spaced Forward 4mm

Rear Camber Link in Front of Rear Tower

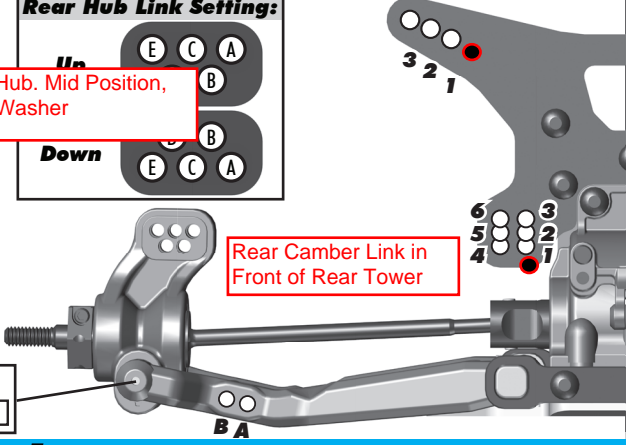

Hub Insert:

+3 +2 +1 0

Electronics:

Radio:	Servo:
EPA: Throttle: % Brake: %	
ESC:	
ESC Settings:	
Motor:	
Wind:	Timing:
Pinion:	Spur:
Battery:	
Battery Position:	

Differential:

Front Fluid:
Gears: Plastic <input type="checkbox"/> Metal <input type="checkbox"/>
Center Fluid:
Gears: Plastic <input type="checkbox"/> Metal <input type="checkbox"/>
Rear Fluid:
Gears: Plastic <input type="checkbox"/> Metal <input type="checkbox"/>
Slipper Clutch:
Type:
of Pads:

Shocks:

	Front	Rear
Piston:		
Fluid:		
Spring:		
Limiters:		
Stroke:		
Eyelet Length:		
Cup Offset:		
Notes:		



Track Info:

Size: Small <input type="checkbox"/> Medium <input type="checkbox"/> Large <input type="checkbox"/> Extra Large <input type="checkbox"/>
Surface: Dirt <input type="checkbox"/> Carpet <input type="checkbox"/> Astroturf <input type="checkbox"/> Multi Surface <input type="checkbox"/>
Traction: Low <input type="checkbox"/> Medium <input type="checkbox"/> High <input type="checkbox"/> Very High <input type="checkbox"/>
Moisture: Dry <input type="checkbox"/> Damp <input type="checkbox"/> Wet <input type="checkbox"/>
Condition: Indoor <input type="checkbox"/> Outdoor <input type="checkbox"/> Dusty <input type="checkbox"/> Hard Packed <input type="checkbox"/>
Bumpy <input type="checkbox"/> Grooved <input type="checkbox"/> Smooth <input type="checkbox"/> Loamy <input type="checkbox"/>
Temperature: Ambient: _____ Track: _____
Notes:

Tires:

Front Tires:
Front Compound:
Front Insert:
Rear Tires:
Rear Compound:
Rear Insert:
Wheel (F/R):
Notes:

Body, Wing, Weight:

Body:
Wing:
Wing Angle: 0° <input type="checkbox"/> 3° <input type="checkbox"/> 6° <input type="checkbox"/>
Chassis Weights:
None <input type="checkbox"/> 15g <input type="checkbox"/> 30g <input type="checkbox"/> Other <input type="checkbox"/>
Other Weights:
Total Vehicle Weight:

Vehicle Comments:

Notes: