

RACE

TRACK

NAME

CITY / COUNTRY

CONTACT

DATE

QUALIFYING POSITION	BEST LAPTIME /sec	FINAL POSITION	RACE LENGTH /min
<input type="text"/>	<input type="text"/>	<input type="text"/>	<input type="text"/>

TRACK

TRACK SURFACE CARPET ASPHALT

TRACK LAYOUT TECHNICAL MIXED FAST

TRACTION LOW MEDIUM HIGH

CENTER SHOCK ABSORBER

SPRING OIL /cSt REBOUND /%

PISTON 2 HOLES 3 HOLES

HOLES DIAMETER /ø 1.1mm 1.2mm 1.3mm

SIDE SHOCK

OIL /cSt

FRONT	TIRES	REAR
<input type="text"/>	TIRES <input type="text"/>	<input type="text"/>
<input type="text"/>	ADDITIVE <input type="text"/>	<input type="text"/>
<input type="text"/>	ADDITIVE TIMING <input type="text"/>	<input type="text"/>
FRONT LEFT <input type="text"/>	ADDITIVE TREATED AREA <input type="text"/>	REAR LEFT <input type="text"/>
FRONT RIGHT <input type="text"/>		REAR RIGHT <input type="text"/>

DIFF SETTING

LOOSE MEDIUM TIGHT

GEARING

PINION /T SPUR GEAR /T FINAL DRIVE RATIO

ELECTRONICS

MOTOR

SPEEDO

BATTERIES

BODY

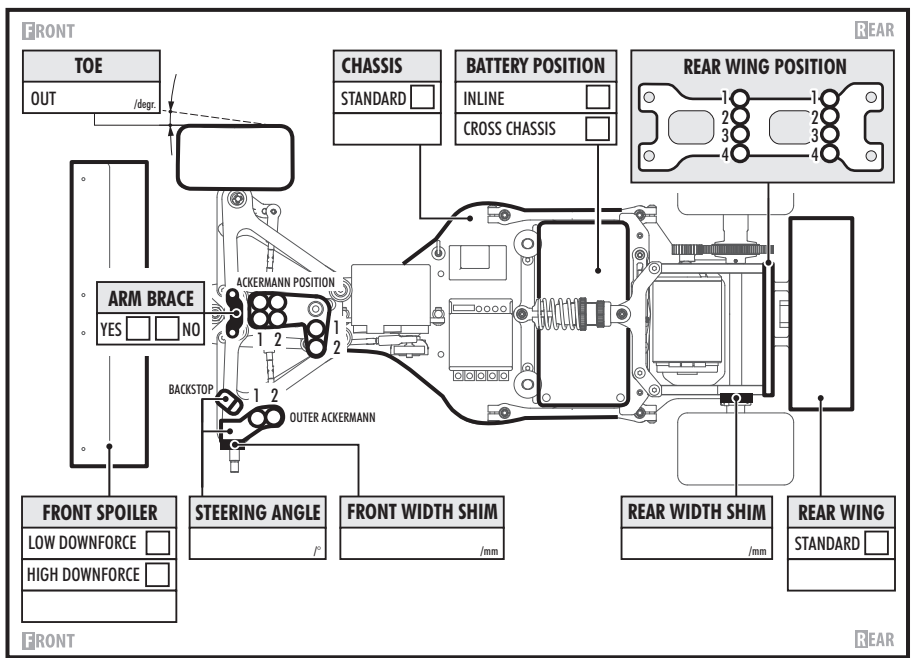
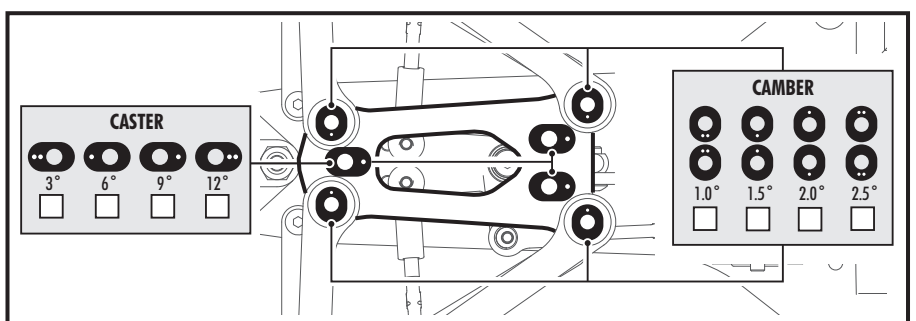
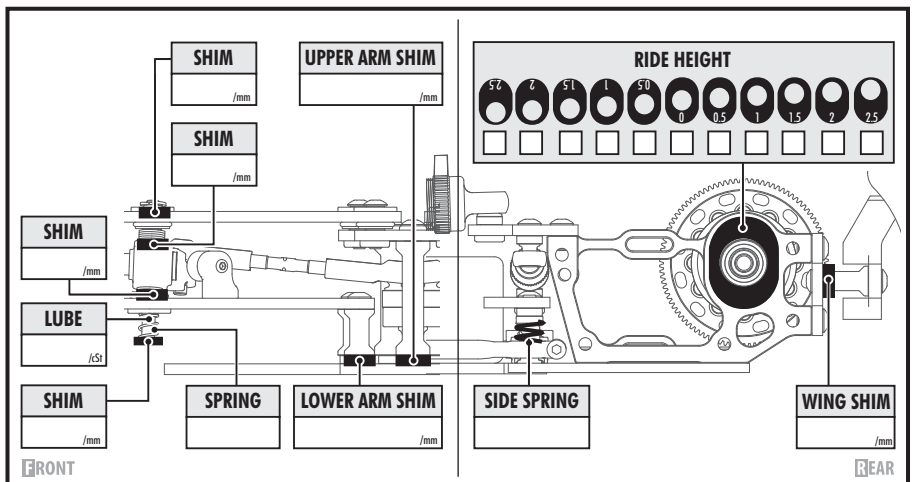
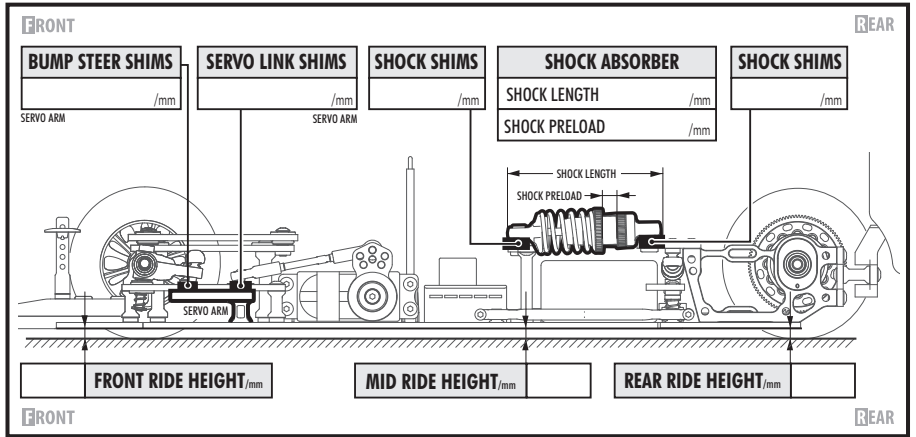

COMMENTS