

RACE	ETS Round 2
TRACK	Muelheim Kaerlich

NAME	Jan Ratheisky
CITY / COUNTRY	M?lheim K?rlich, Germany
CONTACT	j.ratheisky@gmail.com

DATE	08/02/2015
------	------------

QUALIFYING POSITION	BEST LAPTIME /sec	FINAL POSITION	RACE LENGTH /min
1	x	1	5

TRACK		
TRACK SURFACE	<input checked="" type="checkbox"/> CARPET	<input type="checkbox"/> ASPHALT
TRACK LAYOUT	<input type="checkbox"/> TECHNICAL	<input checked="" type="checkbox"/> MIXED
TRACTION	<input type="checkbox"/> LOW	<input checked="" type="checkbox"/> MEDIUM

CENTER SHOCK ABSORBER		
SPRING	OIL /cSt	REBOUND /%
2.2	550	50
PISTON		HOLES DIAMETER /ø
<input type="checkbox"/> 2 HOLES	<input checked="" type="checkbox"/> 3 HOLES	<input type="checkbox"/> 1.1mm
		<input checked="" type="checkbox"/> 1.2mm
		<input type="checkbox"/> 1.3mm

SIDE SHOCK	
OIL /cSt	550

FRONT	TIRES	REAR
Ride	TIRES	Ride
Hudy	ADDITIVE	Hudy
30	ADDITIVE TIMING	20
FRONT LEFT	ADDITIVE TREATED AREA	REAR LEFT
FRONT RIGHT		REAR RIGHT

DIFF SETTING		
<input type="checkbox"/>	<input type="checkbox"/>	<input checked="" type="checkbox"/>
LOOSE	MEDIUM	TIGHT

GEARING		
PINION /T	SPUR GEAR /T	FINAL DRIVE RATIO
38	96	2.52

ELECTRONICS	
MOTOR	Handout
SPEEDO	Handout
BATTERIES	LRP Shorty

BODY
Xray original

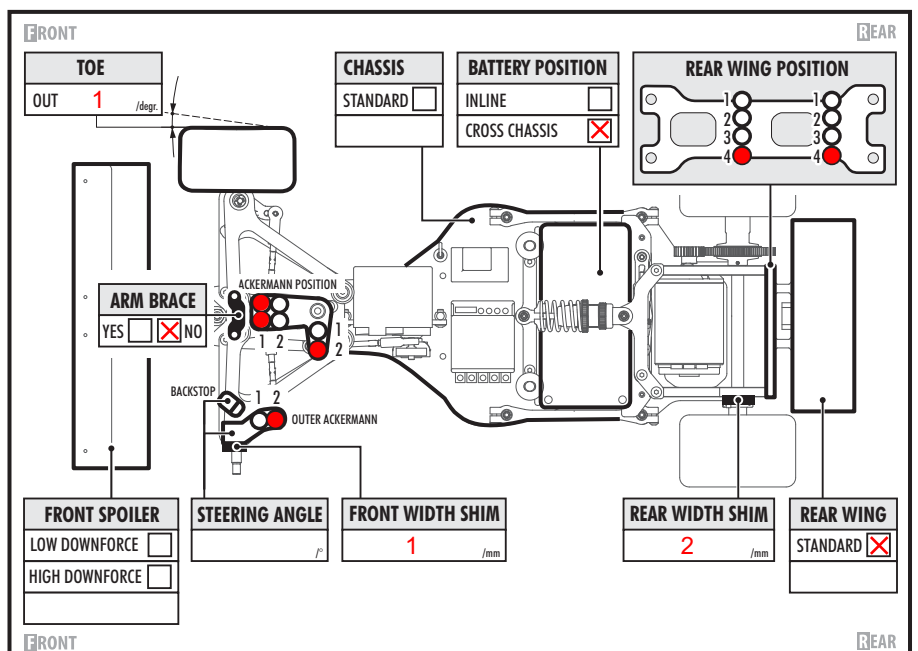
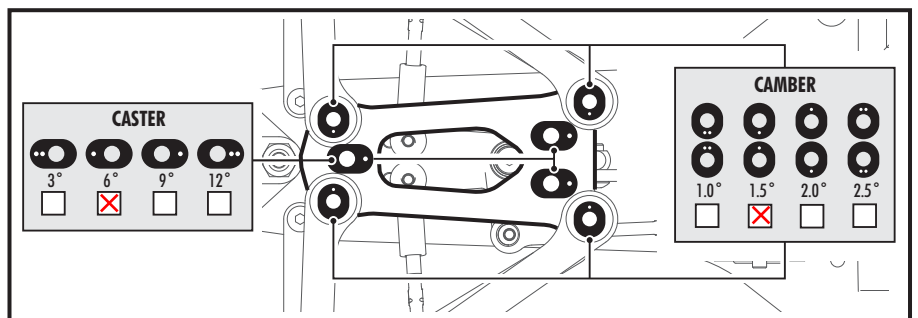
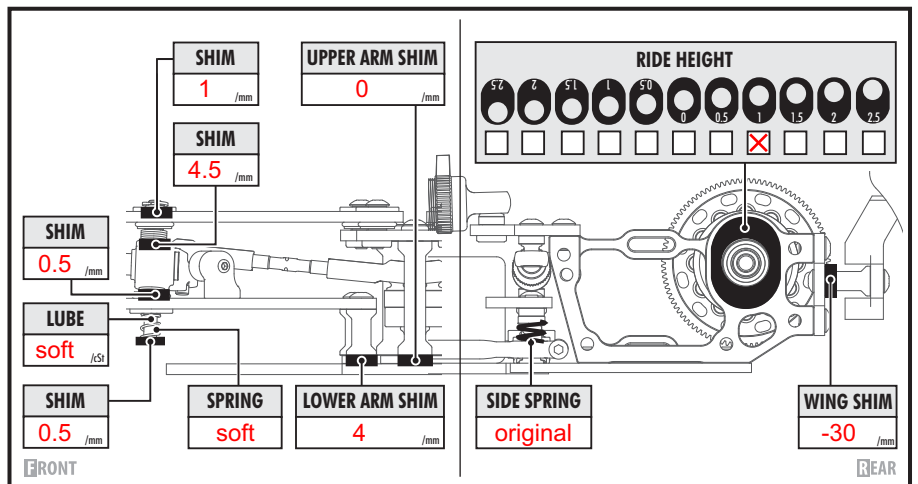
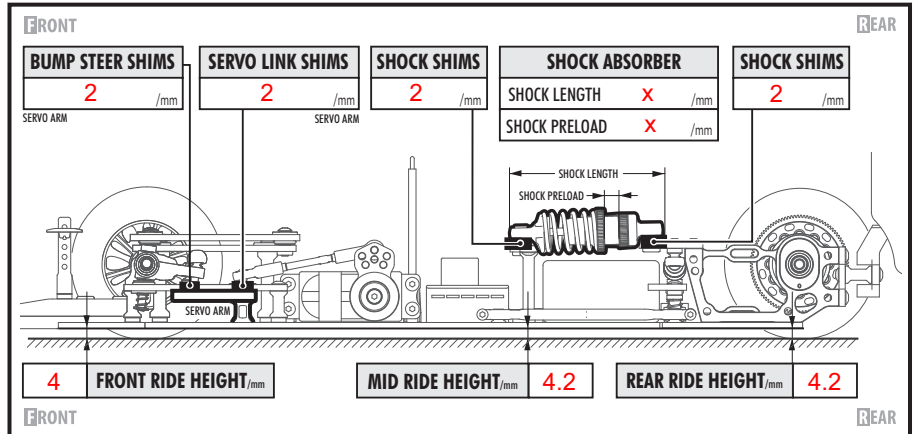

COMMENTS
Rear Wing - Lower Wing cutted and mounted in fron of the carbon holder 2mm Antidive mounted at the rear upper carbon wishbone