

SET-UP SHEET

RACE	ETS Luxemburg starting setup
TRACK	Luxemburg

NAME	Jan Ratheisky
CITY / COUNTRY	Luxembourg, Luxembourg
CONTACT	j.ratheisky@gmail.com

DATE	31/05/2015
------	------------

QUALIFYING POSITION	BEST LAPTIME /sec	FINAL POSITION	RACE LENGTH /min
X	X	X	X

TRACK	
TRACK SURFACE	<input type="checkbox"/> CARPET <input checked="" type="checkbox"/> ASPHALT
TRACK LAYOUT	<input type="checkbox"/> TECHNICAL <input checked="" type="checkbox"/> MIXED <input type="checkbox"/> FAST
TRACTION	<input type="checkbox"/> LOW <input checked="" type="checkbox"/> MEDIUM <input type="checkbox"/> HIGH

CENTER SHOCK ABSORBER		
SPRING	OIL /cSt	REBOUND /%
2.2	450	50
PISTON		HOLES DIAMETER /ø
<input type="checkbox"/> 2 HOLES <input checked="" type="checkbox"/> 3 HOLES	<input type="checkbox"/> 1.1mm <input type="checkbox"/> 1.2mm <input checked="" type="checkbox"/> 1.3mm	

SIDE SHOCK	
OIL /cSt	450

FRONT	TIRES	REAR
Ride	TIRES	Ride
Hudy	ADDITIVE	Hudy
60	ADDITIVE TIMING	60
FRONT LEFT	FRONT RIGHT	REAR LEFT
	ADDITIVE TREATED AREA	

DIFF SETTING	
<input type="checkbox"/>	<input checked="" type="checkbox"/>
LOOSE	TIGHT

GEARING		
PINION /T	SPUR GEAR /T	FINAL DRIVE RATIO
40	88	2.2

ELECTRONICS	
MOTOR	Handout
SPEEDO	Handout
BATTERIES	LRP 2900 LCG

BODY	
Xray	

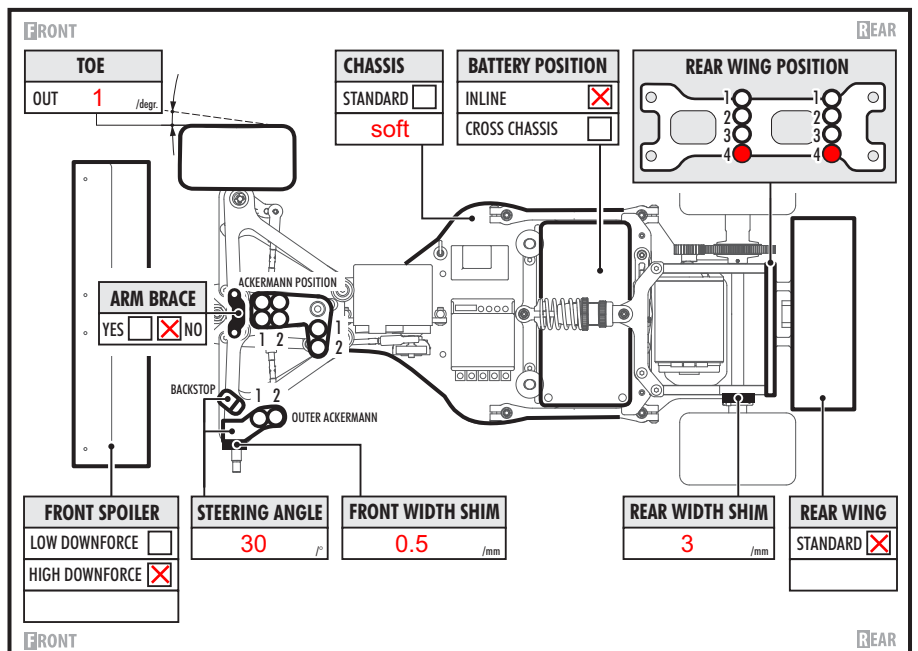
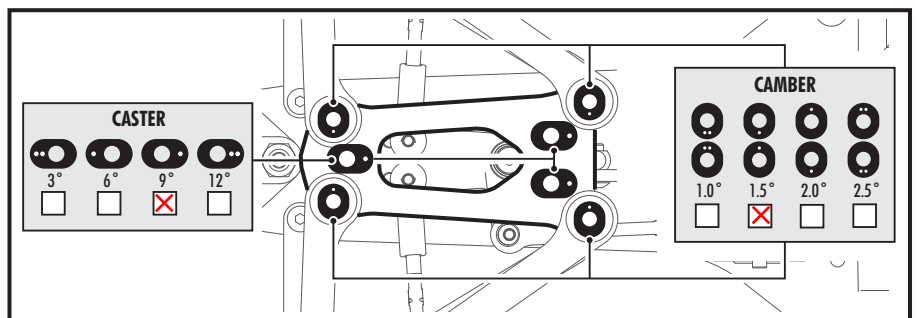
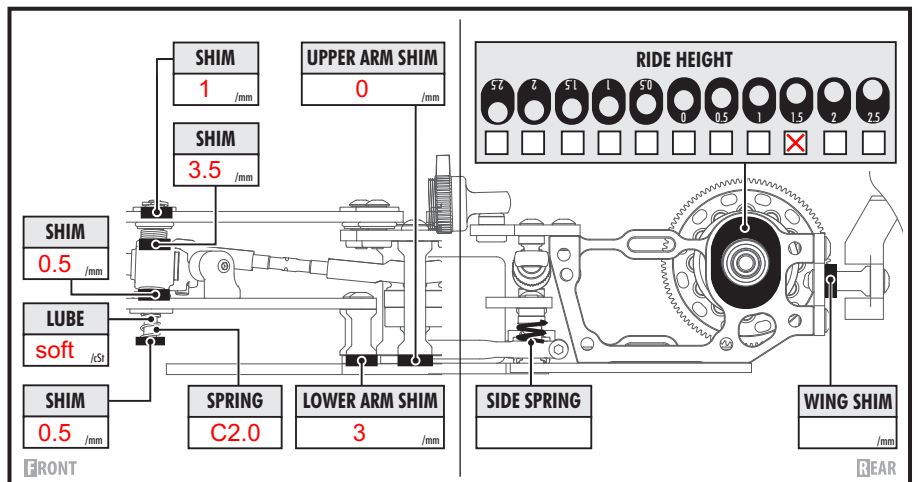
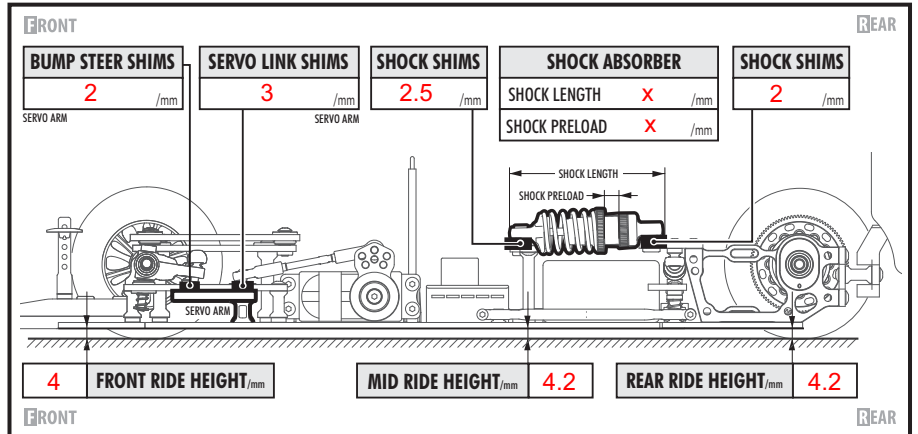

COMMENTS	
----------	--