

SET-UP SHEET

XRAY X1

RACE	2015 ACT Titles
TRACK	Kambah

NAME	Corey Broadstock
CITY / COUNTRY	Canberra, Australia
CONTACT	corey.broadstock93@gmail.com

DATE	31/03/2015
------	------------

QUALIFYING POSITION	BEST LAPTIME /sec	FINAL POSITION	RACE LENGTH /min
3	19.3	1	6

TRACK		
TRACK SURFACE	<input type="checkbox"/> CARPET	<input checked="" type="checkbox"/> ASPHALT
TRACK LAYOUT	<input type="checkbox"/> TECHNICAL	<input type="checkbox"/> MIXED
		<input checked="" type="checkbox"/> FAST
TRACTION	<input checked="" type="checkbox"/> LOW	<input type="checkbox"/> MEDIUM
		<input type="checkbox"/> HIGH

CENTER SHOCK ABSORBER		
SPRING	OIL /cSt	REBOUND /%
2.2	500	0
PISTON		
<input type="checkbox"/> 2 HOLES	<input type="checkbox"/> 3 HOLES	
HOLES DIAMETER /ø		
<input type="checkbox"/> 1.1mm	<input checked="" type="checkbox"/> 1.2mm	<input type="checkbox"/> 1.3mm

SIDE SHOCK	
OIL /cSt	350

FRONT	TIRES	REAR
Pit Medium (573)	TIRES	Ride R1
MR33	ADDITIVE	MR33
30m +	ADDITIVE TIMING	30m +
FRONT LEFT		REAR LEFT
FRONT RIGHT		REAR RIGHT
	ADDITIVE TREATED AREA	

DIFF SETTING		
<input type="checkbox"/>	<input type="checkbox"/>	<input checked="" type="checkbox"/>
LOOSE	MEDIUM	TIGHT

GEARING		
PINION /T	SPUR GEAR /T	FINAL DRIVE RATIO
34	96	

ELECTRONICS	
MOTOR	Muchmore Fleta ZX 21.5t
SPEEDO	Nosram Comet HD
BATTERIES	Muchmore 4600

BODY	
	Xray X1

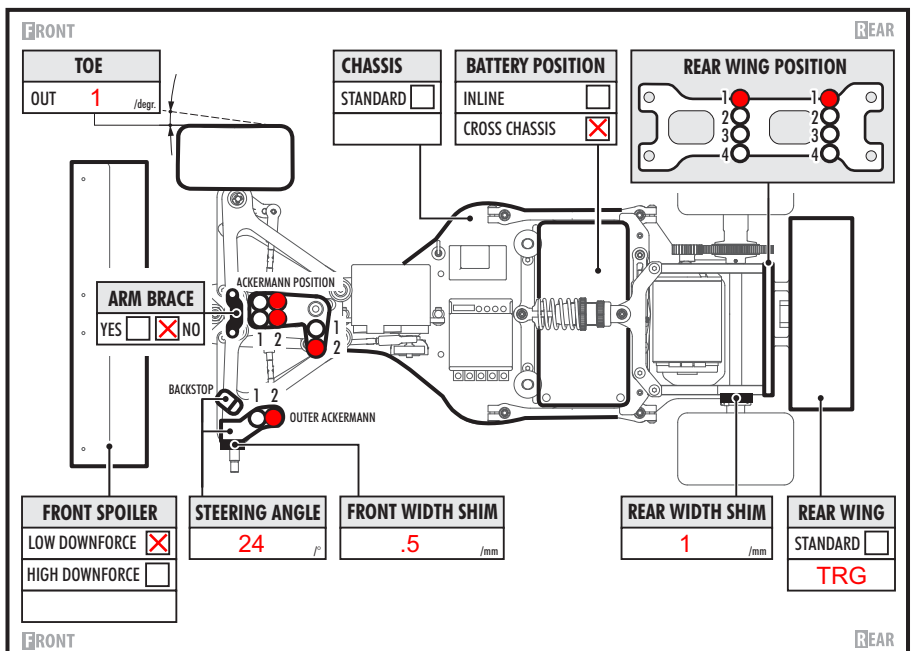
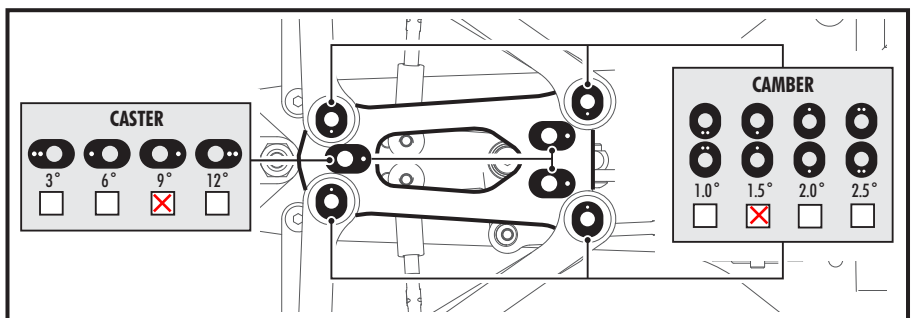
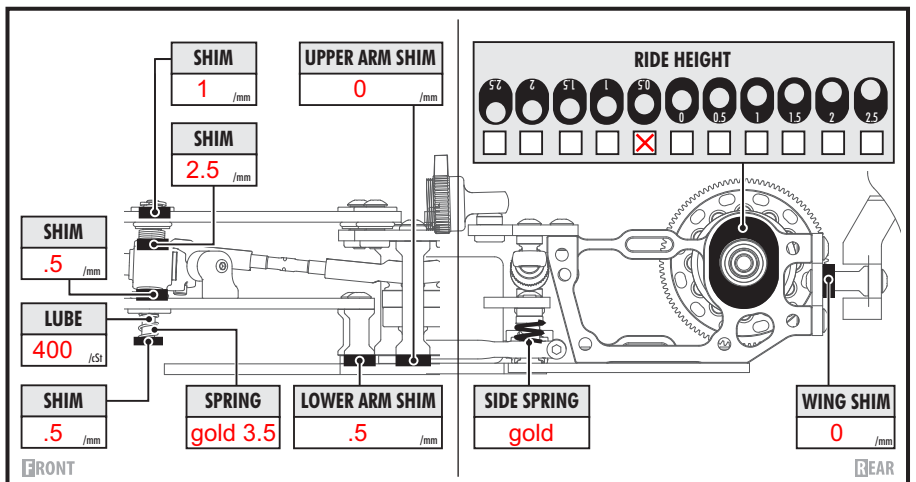
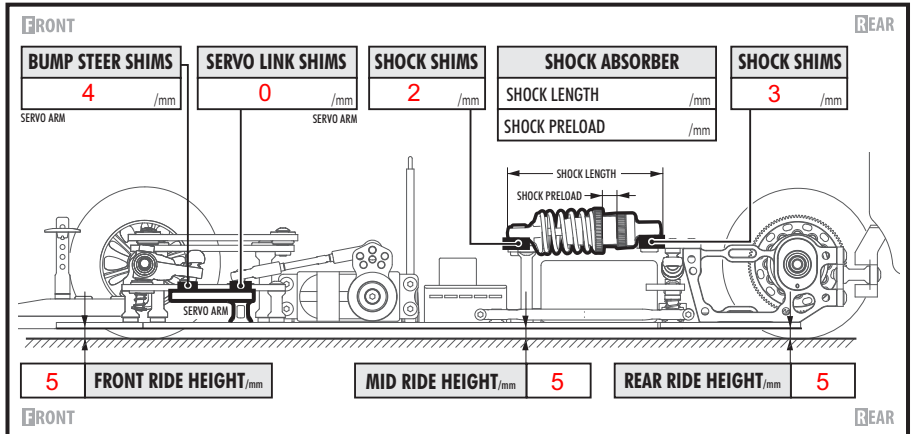

COMMENTS	T4 shock conversion using shaft from kit shock. 4 hole piston
----------	---