



1/10 LUXURY ELECTRIC TOURING CAR

1/10  
2016

MADE IN EUROPE

INSTRUCTION MANUAL

WORLD VICE-CHAMPION

45x USA NATIONAL CHAMPION

EUROPEAN CHAMPION Modified

3x EUROPEAN CHAMPION Stock

16x CAR OF THE YEAR

car action Reader's Choice Award

300+ NATIONAL CHAMPION TITLES

ITS SNOWBURD Nationals WINNER

2016 INTERNATIONAL INDOOR CHAMPION 03-08-17-08-09-15\*

6x DHI CUP WINNER

11x LET TOM WINNER

3x TITE CHAMPION

19x ETS ELKIND TOURING SERIES WINNER

4x ETS ELKIND TOURING SERIES SEASON STOCK WINNER

7x EUROPEAN CHAMPION Junior



## BEFORE YOU START

The T4 is a high-competition, high-quality, 1/10-scale touring car intended for persons aged 16 years and older with previous experience building and operating RC model racing cars. This is not a toy; it is a precision racing model. This model racing car is not intended for use by beginners, inexperienced customers, or by children without direct supervision of a responsible, knowledgeable adult. If you do not fulfill these requirements, please return the kit in unused and unassembled form back to the shop where you have purchased it.

Before building and operating your T4, **YOU MUST** read through all of the operating instructions and instruction manual and fully understand them to get

## CUSTOMER SUPPORT

We have made every effort to make these instructions as easy to understand as possible. However, if you have any difficulties, problems, or questions, please do not hesitate to contact the XRAY support team at [info@teamxray.com](mailto:info@teamxray.com). Also, please visit our Web site at [www.teamxray.com](http://www.teamxray.com) to find the latest updates, set-up information, option parts, and many other goodies. We pride ourselves on taking excellent care of our customers.

You can join thousands of XRAY fans and enthusiasts in our online community at:

[www.teamxray.com](http://www.teamxray.com)

**Failure to follow these instructions will be considered as abuse and/or neglect.**

## SAFETY PRECAUTIONS

Contains:

LEAD (CAS 7439-92-1) ANTIMONY (CAS 7440-36-0)

WARNING: This product contains a chemical known to the state of California to cause cancer and birth defects or other reproductive harm.

CAUTION: CANCER HAZARD

Contains lead, a listed carcinogen. Lead is harmful if ingested. Wash thoroughly after using. DO NOT use product while eating, drinking or using tobacco products. May cause chronic effects to gastrointestinal tract, CNS, kidneys, and blood. MAY CAUSE BIRTH DEFECTS.

When building, using and/or operating this model always wear protective glasses and gloves.

Take appropriate safety precautions prior to operating this model. You are responsible for this model's assembly and safe operation! Please read the instruction manual before building and operating this model and follow all safety precautions. Always keep the instruction manual at hand for quick reference, even after completing the assembly. Use only genuine and original authentic XRAY parts for maximum performance. Using any third party parts on this model will void guaranty immediately.

## IMPORTANT NOTES - GENERAL

- This product is not suitable for children under 16 years of age without the direct supervision of a responsible and knowledgeable adult.
- Carefully read all manufacturers warnings and cautions for any parts used in the construction and use of your model.
- Assemble this kit only in places away from the reach of very small children.
- First-time builders and users should seek advice from people who have building experience in order to assemble the model correctly and to allow the model to reach its performance potential.
- Exercise care when using tools and sharp instruments.
- Take care when building, as some parts may have sharp edges.
- Keep small parts out of reach of small children. Children must not be allowed to put any parts in their mouth, or pull vinyl bag over their head.
- Read and follow instructions supplied with paints and/or cement, if used (not included in kit).
- Immediately after using your model, do NOT touch equipment on the model such as the motor and speed controller, because they generate high temperatures. You may seriously burn yourself seriously touching them.
- Follow the operating instructions for the radio equipment at all times.
- Do not put fingers or any objects inside rotating and moving parts, as this may cause damage or serious injury as your finger, hair, clothes, etc. may get caught.
- Be sure that your operating frequency is clear before turning on or running your model, and never share the same frequency with somebody else at the same time. Ensure that others are aware of the operating frequency you are using and when you are using it.
- Use a transmitter designed for ground use with RC cars. Make sure that no one else is using the same frequency as yours in your operating area. Using the same frequency at the same time, whether it is driving, flying or sailing, can cause loss of control of the RC model, resulting in a serious accident.
- Always turn on your transmitter before you turn on the receiver in the car. Always turn off the receiver before turning your transmitter off.

the maximum enjoyment and prevent unnecessary damage. Read carefully and fully understand the instructions before beginning assembly.

Make sure you review this entire manual, download and use set-up book from the web, and examine all details carefully. If for some reason you decide The T4 is not what you wanted or expected, **do not continue any further**. Your hobby dealer cannot accept your T4 kit for return or exchange after it has been partially or fully assembled.

Contents of the box may differ from pictures. In line with our policy of continuous product development, the exact specifications of the kit may vary without prior notice.

### XRAY Europe

K Vystavisku 6992  
91101 Trenčín  
Slovakia, EUROPE  
Phone: 421-32-7401100  
Fax: 421-32-7401109  
E-mail: [info@teamxray.com](mailto:info@teamxray.com)

### XRAY USA

RC America, 2030 Century Center Blvd #15  
Irving, TX 75062  
USA  
Phone: (800) 519-7221 \* (214) 744-2400  
Fax: (214) 744-2401  
E-mail: [xray@rcamerica.com](mailto:xray@rcamerica.com)

Improper operation may cause personal and/or property damage. XRAY and its distributors have no control over damage resulting from shipping, improper construction, or improper usage. XRAY assumes and accepts no responsibility for personal and/or property damages resulting from the use of improper building materials, equipment and operations. By purchasing any item produced by XRAY, the buyer expressly warrants that he/she is in compliance with all applicable federal, state and local laws and regulation regarding the purchase, ownership and use of the item. The buyer expressly agrees to indemnify and hold harmless XRAY for all claims resulting directly or indirectly from the purchase, ownership or use of the product. By the act of assembling or operating this product, the user accepts all resulting liability. If the buyer is not prepared to accept this liability, then he/she should return this kit in new, unassembled, and unused condition to the place of purchase.

- Keep the wheels of the model off the ground when checking the operation of the radio equipment.
- Disconnect the battery pack before storing your model.
- When learning to operate your model, go to an area that has no obstacles that can damage your model if your model suffers a collision.
- Remove any sand, mud, dirt, grass or water before putting your model away.
- If the model behaves strangely, immediately stop the model, check and clear the problem.
- To prevent any serious personal injury and/or damage to property, be responsible when operating all remote controlled models.
- The model car is not intended for use on public places and roads or areas where its operation can conflict with or disrupt pedestrian or vehicular traffic.
- Because the model car is controlled by radio, it is subject to radio interference from many sources that are beyond your control. Since radio interference can cause momentary loss of control, always allow a safety margin in all directions around the model in order to prevent collisions.
- Do not use your model:
  - Near real cars, animals, or people that are unaware that an RC car is being driven.
  - In places where children and people gather
  - In residential districts and parks
  - In limited indoor spaces
  - In wet conditions
  - In the street
  - In areas where loud noises can disturb others, such as hospitals and residential areas.
  - At night or anytime your line of sight to the model may be obstructed or impaired in any way.

To prevent any serious personal injury and/or damage to property, please be responsible when operating all remote controlled models.

## **IMPORTANT NOTES - ELECTRICAL**

- Insulate any exposed electrical wiring (using heat shrink tubing or electrical tape) to prevent dangerous short circuits. Take maximum care in wiring, connecting and insulating cables. Make sure cables are always connected securely. Check connectors for if they become loose. And if so, reconnect them securely. Never use R/C models with damaged wires. A damaged wire is extremely dangerous, and can cause short-circuits resulting in fire. Please have wires repaired at your local hobby shop.
- Low battery power will result in loss of control. Loss of control can occur due to a weak battery in either the transmitter or the receiver. Weak running battery may also result in an out of control car if your car's receiver power is supplied by the running battery. Stop operation immediately if the car starts to slow down.
- When not using RC model, always disconnect and remove battery.
- Do not disassemble battery or cut battery cables. If the running battery short-circuits, approximately 300W of electricity can be discharged, leading to fire or burns. Never disassemble battery or cut battery cables.
- Use a recommended charger for the receiver and transmitter batteries and follow the instructions correctly. Over-charging, incorrect charging, or using inferior chargers can cause the batteries to become dangerously hot.

## **R/C & BUILDING TIPS**

- Make sure all fasteners are properly tightened. Check them periodically.
- Make sure that chassis screws do not protrude from the chassis.
- For the best performance, it is very important that great care is taken to ensure the free movement of all parts.
- Clean all ball-bearings so they move very easily and freely.
- Tap or pre-thread the plastic parts when threading screws.
- Self-tapping screws cut threads into the parts when being tightened. Do not use excessive force when tightening the self-tapping screws because you may strip out the thread in the plastic. We recommended you stop tightening a screw when you feel some resistance.
- Ask your local hobby shop for any advice.

## **WARRANTY**

XRAY guarantees this model kit to be free from defects in both material and workmanship within 30 days of purchase. The total monetary value under warranty will in no case exceed the cost of the original kit purchased. This warranty does not cover any components damaged by use or modification or as a result of wear. Part or parts missing from this kit must be reported within 30 days of purchase. No part or parts will be sent under warranty without proof of purchase. Should you find a defective or missing part, contact the local distributor. Service and customer support will be provided through local hobby store where you have purchased the kit, therefore make sure to purchase any XRAY products at your local hobby store. This model racing car is considered to be a high-performance racing vehicle. As such this vehicle will be used in an extreme range of conditions and situations, all which may cause premature wear or failure of any component. XRAY has no control over usage of vehicles once they leave the dealer, therefore XRAY can only offer warranty against all manufacturer's defects in materials, workmanship, and assembly at point of sale and before use. No warranties are expressed or implied that cover damage caused by what is considered normal use, or cover or imply how long any model cars' components or electronic components will last before requiring replacement.

Due to the high performance level of this model car you will need to periodically maintain and replace consumable components. Any and all warranty coverage will not cover replacement of any part or component damaged by neglect, abuse, or improper or unreasonable use. This includes but is not limited to

## **QUALITY CERTIFICATE**

XRAY MODEL RACING CARS uses only the highest quality materials, the best compounds for molded parts and the most sophisticated manufacturing processes of TQM (Total Quality Management). We guarantee that all parts of a newly-purchased kit are manufactured with the highest regard to quality. However, due to the many factors inherent in model racecar competition, we cannot guarantee

Recharge battery when necessary. Continual recharging may damage battery and, in the worst case, could build up heat leading to fire. If battery becomes extremely hot during recharging, please ask your local hobby shop for check and/or repair and/or replacement.

- Regularly check the charger for potential hazards such as damage to the cable, plug, casing or other defects. Ensure that any damage is rectified before using the charger again. Modifying the charger may cause short-circuit or overcharging leading to a serious accident. Therefore do not modify the charger.
- Always unplug charger when recharging is finished.
- Do not recharge battery while battery is still warm. After use, battery retains heat. Wait until it cools down before charging.
- Do not allow any metal part to short circuit the receiver batteries or other electrical/electronic device on the model.
- Immediately stop running if your RC model gets wet as may cause short circuit.
- Please dispose of batteries responsibly. Never put batteries into fire.

Please support your local hobby shop. We at XRAY Model Racing Cars support all local hobby dealers. Therefore we ask you, if at all possible, to purchase XRAY products at your hobby dealer and give them your support like we do. If you have difficulty finding XRAY products, please check out [www.teamxray.com](http://www.teamxray.com) to get advice, or contact us via email at [info@teamxray.com](mailto:info@teamxray.com), or contact the XRAY distributor in your country.

damage from crashing, chemical and/or water damage, excessive moisture, improper or no maintenance, or user modifications which compromise the integrity of components. Warranty will not cover components that are considered consumable on RC vehicles. XRAY does not pay nor refund shipping on any component sent to XRAY or its distributors for warranty. XRAY reserves the right to make the final determination of the warranty status of any component or part.

### **Limitations of Liability**

XRAY makes no other warranties expressed or implied. XRAY shall not be liable for any loss, injury or damages, whether direct, indirect, special, incidental, or consequential, arising from the use, misuse, or abuse of this product and/or any product or accessory required to operate this product. In no case shall XRAY's liability exceed the monetary value of this product.

**Take adequate safety precautions prior to operating this model. You are responsible for this model's assembly and safe operation.**

**Disregard of the any of the above cautions may lead to accidents, personal injury, or property damage. XRAY MODEL RACING CARS assumes no responsibility for any injury, damage, or misuse of this product during assembly or operation, nor any addictions that may arise from the use of this product.**

**All rights reserved.**

any parts once you start racing the car. Products which have been worn out, abused, neglected or improperly operated will not be covered under warranty. We wish you enjoyment of this high-quality and high-performance RC car and wish you best success on the track!

**In line with our policy of continuous product development, the exact specifications of the kit may vary. In the unlikely event of any problems with your new kit, you should contact the model shop where you purchased it, quoting the part number.**

**We do reserve all rights to change any specification without prior notice. All rights reserved.**

# SYMBOLS USED

|                           |  |   |   |   |                               |                          |                               |
|---------------------------|--|---|---|---|-------------------------------|--------------------------|-------------------------------|
| <b>Part bags used</b><br> | <b>Assemble in the specified order</b><br> | <b>Assemble left and right sides the same way</b><br> | <b>Pay attention here</b><br>                 | <b>Assemble as many times as specified (here twice)</b><br> | <b>Apply thread lock</b><br>  | <b>Apply CA glue</b><br> | <b>Apply oil</b><br>          |
| <b>Scale</b><br>          | <b>Apply grease</b><br>                    | <b>Optional parts</b><br>                             | <b>Ensure smooth non-binding movement</b><br> | <b>Tighten screw gently</b><br>                             | <b>Completed assembly</b><br> | <b>Detail</b><br>        | <b>Follow Set-Up Book</b><br> |

# TOOLS REQUIRED

|   |  |  |                        |   |  |                                    |
|---|--|--|------------------------|---|--|------------------------------------|
| <b>HUDY TOOLS: Allen: 1.5mm, 2.0mm, 3.0mm, Socket: 5.5mm, 7.0mm</b><br> | <b>Combination Pliers (HUDY #189020)</b><br> | <b>Side Cutters (HUDY #189010)</b><br> | <b>Hobby Knife</b><br> | <b>Turnbuckle Wrench 4mm (HUDY #181040)</b><br> | <b>Reamer (HUDY #107600) or (HUDY #107601)</b><br> | <b>Scissors (HUDY #188990)</b><br> |
|---|--|--|------------------------|---|--|------------------------------------|

# EQUIPMENT INCLUDED

|   |   |
|---|---|
| <b>XRAY Premium Silicone Oil 400cSt (#359240) Oil 2000cSt (#359302)</b><br> | <b>Graphite Grease (HUDY #106210)</b><br> |
|---|---|

# NOT INCLUDED

|                          | <p>To ensure that you always have access to the most up-to-date version of the XRAY Set-up Book, XRAY will now be offering only the digital online version at our Web site at <a href="http://www.teamxray.com">www.teamxray.com</a>. By offering this online version instead of including a hardcopy printed version in kits, you will always be assured of having the most current updated version.</p> | <table border="1"> <thead> <tr> <th colspan="2">SAMPLE OF OPTIONAL PARTS</th> </tr> </thead> <tbody> <tr> <td>#30XXXX</td> <td>OPTION 1</td> </tr> <tr> <td>#30XXXX</td> <td>OPTION 2</td> </tr> <tr> <td>#30XXXX</td> <td>OPTION 3</td> </tr> </tbody> </table> | SAMPLE OF OPTIONAL PARTS |  | #30XXXX | OPTION 1 | #30XXXX | OPTION 2 | #30XXXX | OPTION 3 | <p>XRAY offers wide range of optional tuning parts which are listed in a table like this. Please refer to the exploded view of each main section to verify which part is included in the kit while all other parts are available only as an optional part and must be purchased separately.</p> |
|--------------------------|---|--|--------------------------|--|---------|----------|---------|----------|---------|----------|---|
| SAMPLE OF OPTIONAL PARTS |   |  |                          |  |         |          |         |          |         |          |   |
| #30XXXX                  | OPTION 1  |  |                          |  |         |          |         |          |         |          |   |
| #30XXXX                  | OPTION 2  |  |                          |  |         |          |         |          |         |          |   |
| #30XXXX                  | OPTION 3  |  |                          |  |         |          |         |          |         |          |   |

# EQUIPMENT REQUIRED

|                            |                         |                           |  |  |   |
|----------------------------|-------------------------|---------------------------|--|--|---|
| <b>Transmitter</b><br>     | <b>Receiver</b><br>     | <b>Steering Servo</b><br> | <b>Electric Motor &amp; Pinion Gear and Setscrew</b><br> | <b>Bearing Oil (HUDY #106230)</b><br>                  | <b>Speed Controller</b><br>                 |
| <b>190mm Bodyshell</b><br> | <b>LiPo Battery</b><br> | <b>Lexan™ Paint</b><br>   | <b>Battery Charger</b><br>                               | <b>Fibre Tape (HUDY #107870) Double-sided Tape</b><br> | <b>Wheels &amp; Tires &amp; Inserts</b><br> |

# COLOR INDICATIONS

At the beginning of each section is an exploded view of the parts to be assembled. There is also a list of all the parts and part numbers that are related to the assembly of that section.

The part descriptions are color-coded to make it easier for you to identify the source of a part. Here are what the different colors mean:

Style A - indicates parts that are included in the bag marked for the section.

STYLE B - indicates parts that are included in the box.

STYLE C - indicates parts that are already assembled from previous steps.

# CHASSIS PREPARATION

To protect and seal edges of graphite parts, sand edges smooth and then apply CA glue.

Do this for: chassis edges, countersunk holes, and shock towers.

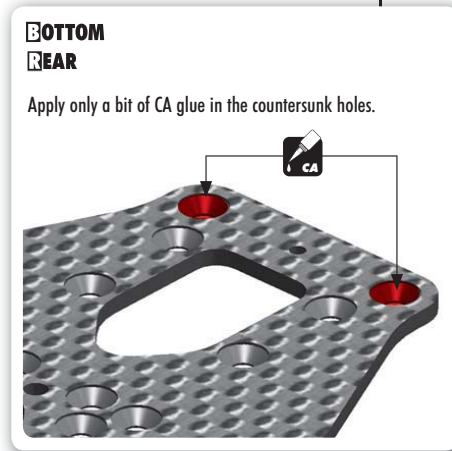
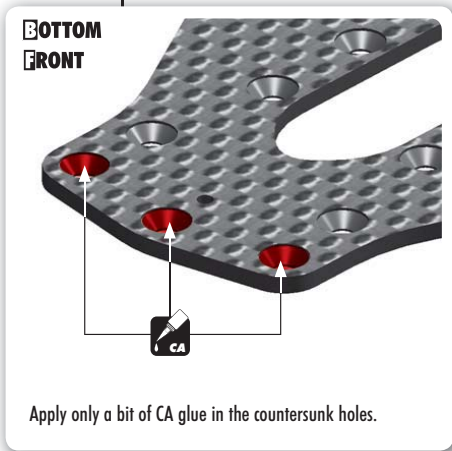
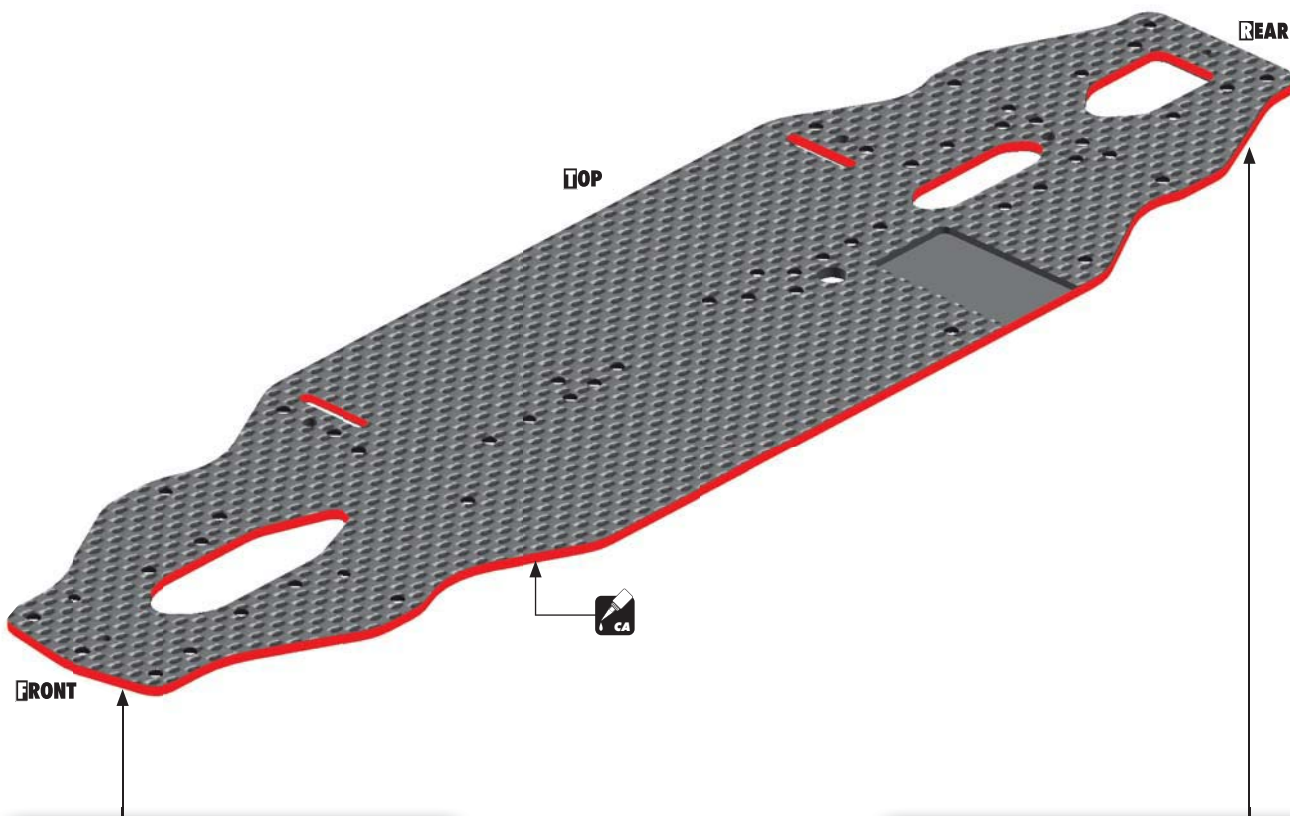



# 1. GEAR DIFFERENTIAL & FRONT SOLID AXLE

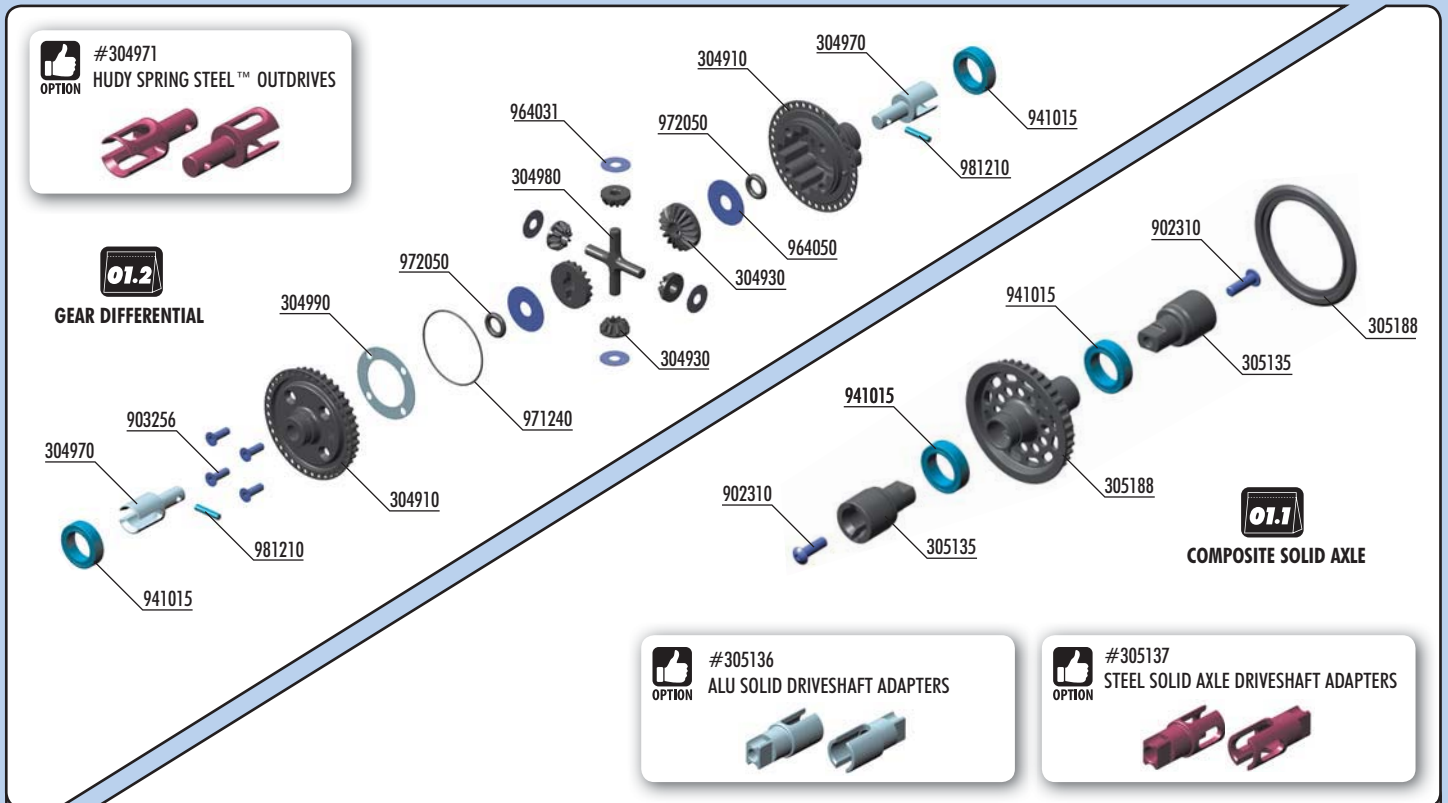

**BAG**

**01.1**

**01.2**

- 30 4900 XRAY GEAR DIFFERENTIAL - SET
- 30 4910 COMPOSITE GEAR DIFF CASE & COVER
- 30 4930 COMPOSITE GEAR DIFF BEVEL & SATELLITE GEARS (2+4)
- 30 4970 ALU GEAR DIFF OUTDRIVE ADAPTER - 7075 T6 (2)
- 30 4980 COMPOSITE GEAR DIFF CROSS PIN
- 30 4990 DIFF GASKET (4)
- 30 5105 XRAY MULTI-DIFF T3/T4 LiPo (OPTION)
- 30 5135 COMPOSITE SOLID AXLE DRIVESHAFT ADAPTERS (2)
- 30 5188 COMPOSITE SOLID AXLE 38T - SET

- 90 2310 HEX SCREW SH M3x10 (10)
- 90 3256 HEX SCREW SFH M2.5x6 (10)
- 94 1015 HIGH-SPEED BALL-BEARING 10x15x4 RUBBER SEALED (2)
- 96 4031 WASHER S 3.5x10x0.2 (10)
- 96 4050 WASHER S 5x15x0.3 (10)
- 97 1240 SILICONE O-RING 24x0.7 (10)
- 97 2050 SILICONE O-RING 5x2 (10)
- 98 1210 PIN 2x10 (10)

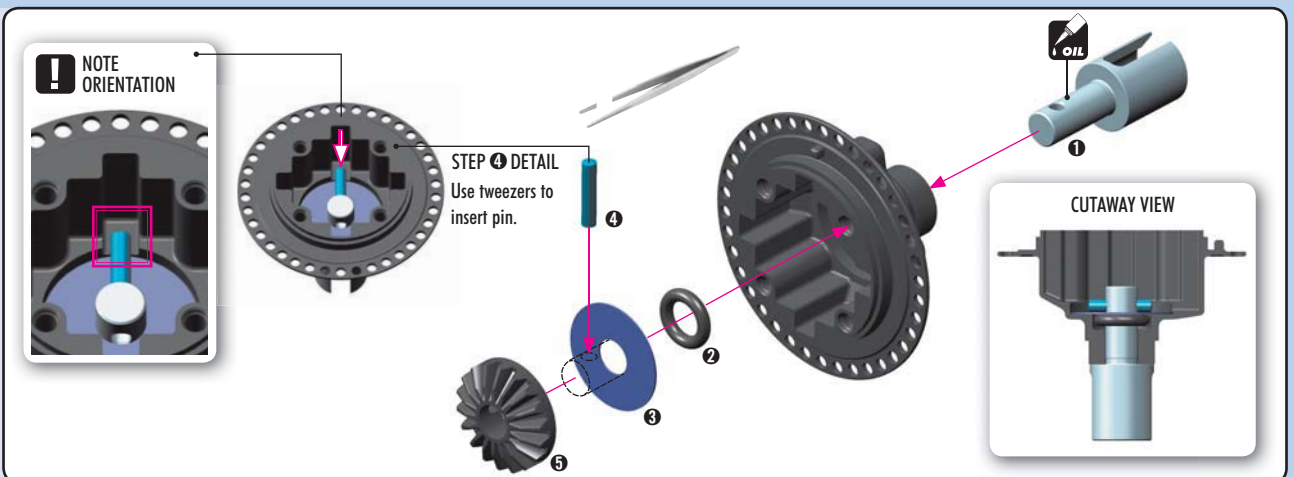
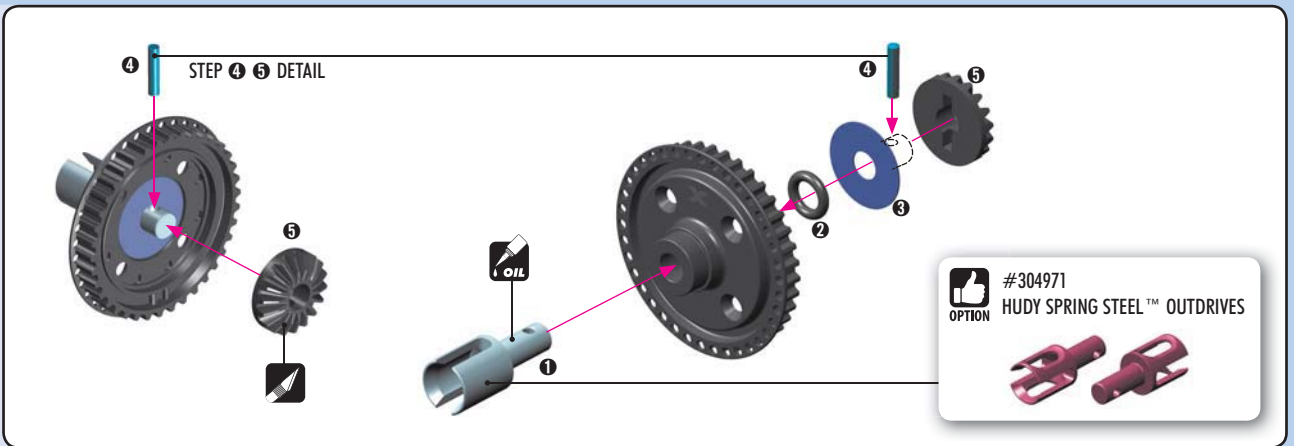

# 1. GEAR DIFFERENTIAL & FRONT SOLID AXLE

964031  
S 3.5x10x0.2

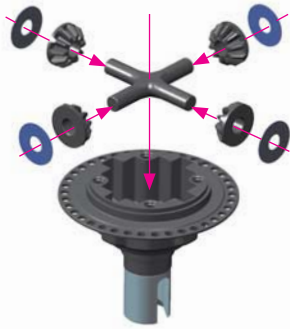

**OIL**

**TIP**



Fill differential up to the top of the diff pin. DO NOT fill the diff to the top of the housing.

TO ENSURE YOU HAVE THE SAME AMOUNT OF OIL FROM REBUILD TO REBUILD, DO THE FOLLOWING:



7.90g

#107865  
HUDY Ultimate Digital Pocket  
Scale 300g ± 0.01g



9.20g

1 Put the diff (without oil) on the scale and check the weight (approximately 7.90g)

$$7.9g + 1.3g = 9.2g$$

2 Slowly pour oil into the diff and watch the weight. Add 1.3g of oil into the diff. The approximate weight of the diff including oil is 9.20g.

**TIP**

## TIPS FOR DIFFERENTIALS

**TIP**

### LOW-TRACTION

1000cSt (HUDY #106410)  
2000cSt (HUDY #106420)

### MEDIUM-TRACTION

2000cSt (HUDY #106420)  
3000cSt (HUDY #106430)  
5000cSt (HUDY #106450)

### HIGH-TRACTION

5000cSt (HUDY #106450)  
6000cSt (HUDY #106460)  
7000cSt (HUDY #106470)  
8000cSt (HUDY #106480)  
9000cSt (HUDY #106490)  
10000cSt (HUDY #106510)

### SUPER HIGH-TRACTION

10000cSt (HUDY #106510)  
15000cSt (HUDY #106515)  
20000cSt (HUDY #106520)

### NOTE

Softer oil increases rear traction, harder oil increases on-power steering and stability. It is important not to use soft oils in high-traction conditions as this would not increase traction, but would make the car loose as the car would become too twitchy.

However, if the oil is too soft, it could generate the same effect like the car has no traction. Therefore it is very important to choose the correct oil very carefully. We suggest to using softer oil first, then try harder oil to better understand the effect on the car's behavior at the track. Choose the oil accordingly.

### TIP TIPS FOR FRONT DIFFERENTIAL

To increase on-power steering and cornering speed, the gear diff can also be used in the front. **NOTE:** If you use the gear diff in the front, we recommend using optional #304971 HUDY Spring Steel™ outrives because the stress on the outrives in the front is much higher than in the rear.

### USE THESE OILS FOR FRONT DIFFERENTIAL

500,000 cSt (HUDY #106650)  
1,000,000 cSt (HUDY #106692)

To make the front differential tighter, you can use cleaning gum instead of oil.

### IMPORTANT!

Using cleaning gum instead of oil in the gear differential can lead to gear breakage because the gears are working under dry conditions.

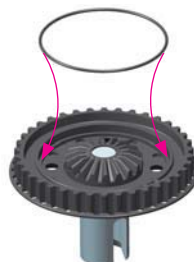
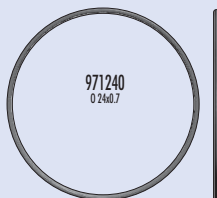

**!**

After disassembling the gear diff the large O-ring may have an increased size and may be more difficult to re-install. We recommend either inserting the old O-ring carefully in the diff cover, or replacing the old O-ring with a new O-ring if the old one cannot be made to fit properly.

# 1. GEAR DIFFERENTIAL & FRONT SOLID AXLE



**BOTTOM**

**NOTE ORIENTATION**

**DETAIL**

Tighten the screws equally but do NOT tighten them completely.

Finish tightening in this order.



BEARING OIL (HUDY #106230)

BEARING OIL (HUDY #106230)

## COMPOSITE FRONT SOLID AXLE



BEARING OIL (HUDY #106230)

BEARING OIL (HUDY #106230)

| FRONT & REAR AXLES |                                 |
|--------------------|---------------------------------|
| #304900            | GEAR DIFFERENTIAL               |
| #305188            | COMPOSITE SOLID AXLE 38T PULLEY |

**CUTAWAY VIEW**

**#305137**  
OPTION STEEL SOLID AXLE DRIVESHAFT ADAPTERS

**#305136**  
OPTION ALU SOLID DRIVESHAFT ADAPTERS





## 2. CENTRAL TRANSMISSION

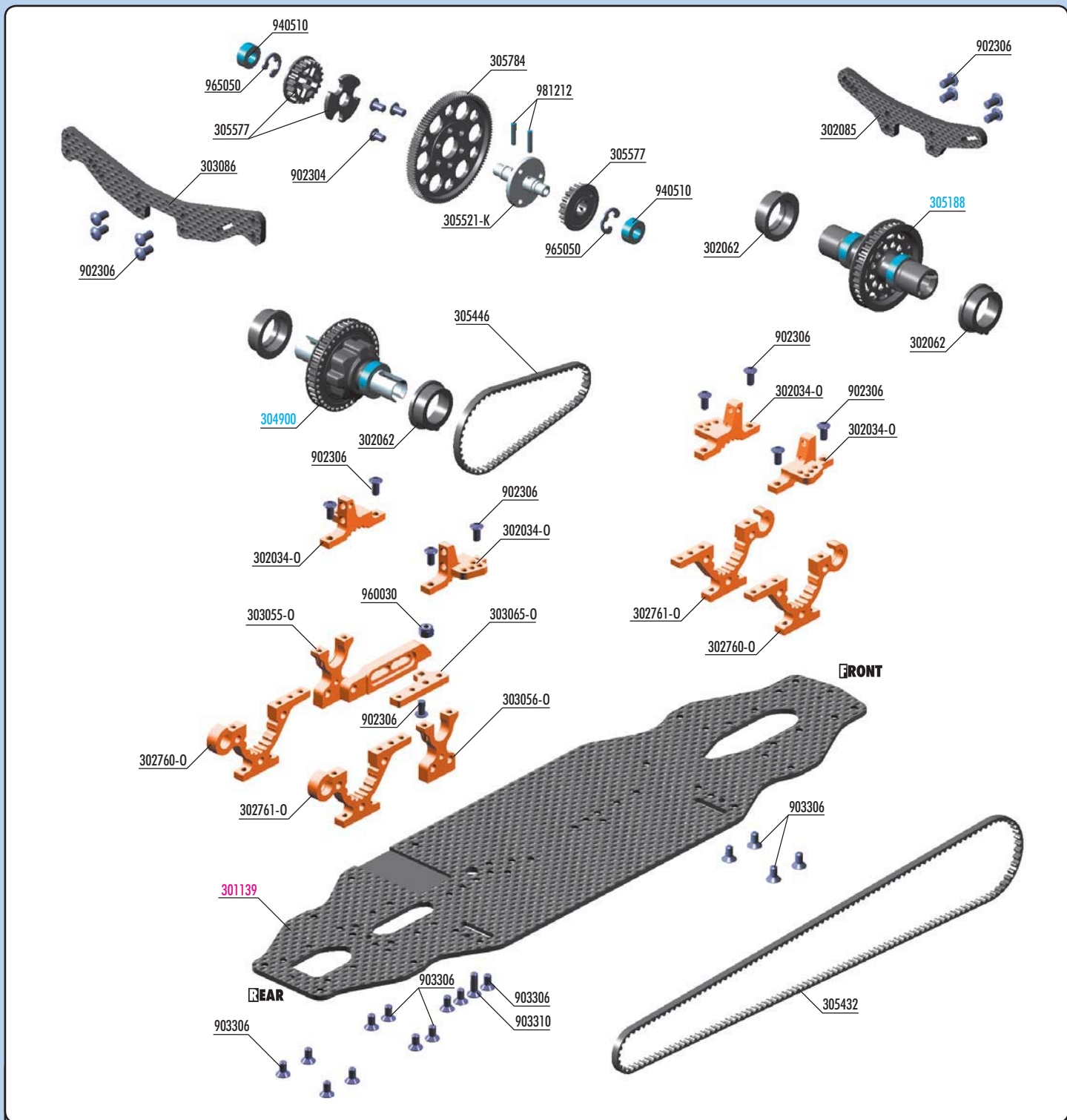

BAG

02

- |           |   |         |                                     |
|-----------|---|---------|-------------------------------------|
| 30 2034-0 | T4 ALU UPPER CLAMP WITH 5 ADJ. ROLL-CENTERS (L + R) - ORANGE    | 30 5874 | OFFSET SPUR GEAR 104T / 64 (OPTION) |
| 30 2062   | T4 COMPOSITE ADJUSTMENT BALL-BEARING HUB (4)                    | 30 5876 | OFFSET SPUR GEAR 106T / 64 (OPTION) |
| 30 2085   | T4 SHOCK TOWER FRONT 3.0MM GRAPHITE                             | 30 5878 | OFFSET SPUR GEAR 108T / 64 (OPTION) |
| 30 2760-0 | T4'15 ALU LOWER ADJUSTMENT BULKHEAD - FRONT R / REAR L - ORANGE | 30 5880 | OFFSET SPUR GEAR 110T / 64 (OPTION) |
| 30 2761-0 | T4'15 ALU LOWER ADJUSTMENT BULKHEAD - FRONT L / REAR R - ORANGE | 30 5882 | OFFSET SPUR GEAR 112T / 64 (OPTION) |
| 30 3055-0 | T4'15 ALU MOTOR MOUNT - ORANGE                                  | 30 5884 | OFFSET SPUR GEAR 114T / 64 (OPTION) |
| 30 3056-0 | T4 ALU LAYSHAFT BULKHEAD CLOSED L/R - ORANGE                    | 90 2304 | HEX SCREW SH M3x4 - STAINLESS (10)  |
| 30 3065-0 | T4'16 ALU MOTOR MOUNT PLATE - ORANGE                            | 90 2306 | HEX SCREW SH M3x6 (10)              |
| 30 3086   | T4 SHOCK TOWER REAR 3.0MM GRAPHITE                              | 90 3306 | HEX SCREW SFH M3x6 (10)             |
| 30 5432   | HIGH-PERFORMANCE KEVLAR DRIVE BELT FRONT 3 x 513 MM             | 90 3310 | HEX SCREW SFH M3x10 (10)            |
| 30 5446   | HIGH-PERFORMANCE KEVLAR DRIVE BELT REAR 3 x 189 MM              | 96 0030 | HEX SCREW SFH M3x10 (10)            |
| 30 5521-K | ALU SOLID LAYSHAFT - BLACK                                      | 96 5050 | E-CLIP 5 (10)                       |
| 30 5577   | COMPOSITE FIXED PULLEY 20T (2)                                  | 98 1212 | PIN 2x12 (10)                       |
| 30 5778   | OFFSET SPUR GEAR 78T / 48 (OPTION)                              |         |                                     |
| 30 5781   | OFFSET SPUR GEAR 81T / 48 (OPTION)                              | 30 4900 | XRAY GEAR DIFFERENTIAL - SET        |
| 30 5784   | SPUR GEAR 84T / 48  | 30 5188 | COMPOSITE SOLID AXLE 38T - SET      |
| 30 5862   | OFFSET SPUR GEAR 92T / 64 (OPTION)                              |         |                                     |
| 30 5866   | OFFSET SPUR GEAR 96T / 64 (OPTION)                              | 30 1139 | T4'16 CHASSIS 2.2MM GRAPHITE        |
| 30 5870   | OFFSET SPUR GEAR 100T / 64 (OPTION)                             |         |                                     |

# 2. CENTRAL TRANSMISSION

**902306**  
SH M3x6

**903306**  
SFH M3x6

**903310**  
SFH M3x10

**960030**  
N M3

**NOTE ORIENTATION**

Do not tighten fully !

REAR

FRONT

Do not tighten fully

It is not necessary to use these screws. The screws are used for motor mount flex setting.

SH M3x6

**NOTE ORIENTATION**

**IMPORTANT!**

Tighten screws in order indicated.

M3 nut must always be tightened fully. When tightening the nut, use pliers.

**902304**  
SH M3x4

**965050**  
CS

**981212**  
P 2x12

1.

2.

3.

**SPUR GEARS 48P**

|         |                            |
|---------|----------------------------|
| #305778 | OFFSET SPUR GEAR 78T / 48P |
| #305781 | OFFSET SPUR GEAR 81T / 48P |
| #305784 | SPUR GEAR 84T / 48P        |

**SPUR GEARS 64P**

|         |                             |
|---------|-----------------------------|
| #305862 | OFFSET SPUR GEAR 92T / 64P  |
| #305866 | OFFSET SPUR GEAR 96T / 64P  |
| #305870 | OFFSET SPUR GEAR 100T / 64P |
| #305874 | OFFSET SPUR GEAR 104T / 64P |
| #305876 | OFFSET SPUR GEAR 106T / 64P |
| #305878 | OFFSET SPUR GEAR 108T / 64P |
| #305880 | OFFSET SPUR GEAR 110T / 64P |
| #305882 | OFFSET SPUR GEAR 112T / 64P |
| #305884 | OFFSET SPUR GEAR 114T / 64P |

**Note orientation only when using XRAY OFFSET spur gears.**

**CUTAWAY VIEW**

**SET-UP BOOK**

GEARING ADJUSTMENT

**940510**  
BB 5x10x4

**NOTE ORIENTATION**

BEARING OIL (HUDY #106230)

Short belt

Long belt

LONGER

SHORTER

FRONT

REAR

NOTE ORIENTATION

**NOTE ORIENTATION**



## 2. CENTRAL TRANSMISSION

### FRONT BELT TENSION ADJUSTMENT

Front diff **upper** position provides **more steering** but provides **less front traction**.

Front diff **lower** position provides **more front traction** but makes the car **push more on power**.

Recommended for **medium-high** grip tracks and technical tracks.

Recommended for **low traction** tracks.

FRONT

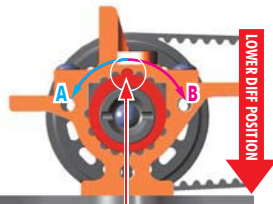
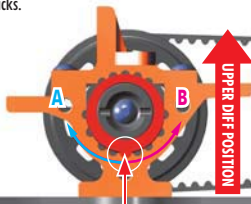

**INITIAL POSITION FOR CARPET**  
Place tab in this **BOTTOM NOTCH**

**INITIAL POSITION FOR ASPHALT**  
Place tab in this **TOP NOTCH**

**TO LOOSEN FRONT BELT:** Rotate both front nylon hubs in arrow direction **A**

**TO TIGHTEN FRONT BELT:** Rotate both front nylon hubs in arrow direction **B**

### REAR BELT TENSION ADJUSTMENT

Rear diff **upper** position provides **more on-power steering** but makes the rear slightly **more loose**.

Rear diff **lower** position provides **more rear traction**, mainly **on-power traction** and makes the car **more stable in the chicanes**, but makes the car **push more on power**.

Recommended for **medium-high traction** tracks.

Recommended for **low-medium** traction tracks.

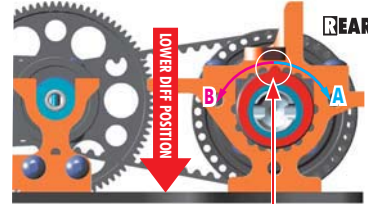
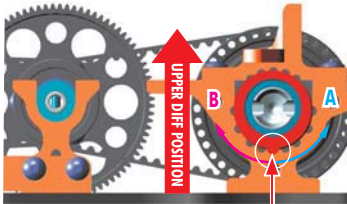

**INITIAL POSITION FOR CARPET**  
Place tab in this **BOTTOM NOTCH**

**INITIAL POSITION FOR ASPHALT**  
Place tab in this **TOP NOTCH**

**TO LOOSEN REAR BELT:** Rotate both rear nylon hubs in arrow direction **A**

**TO TIGHTEN REAR BELT:** Rotate both rear nylon hubs in arrow direction **B**

### #303071 BELT TENSIONER

OPTION

May be used when the front belt becomes worn and loose. Belt tensioner is **NOT** included in the kit and must be purchased separately.

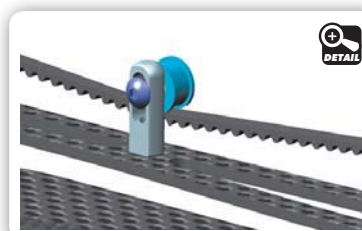
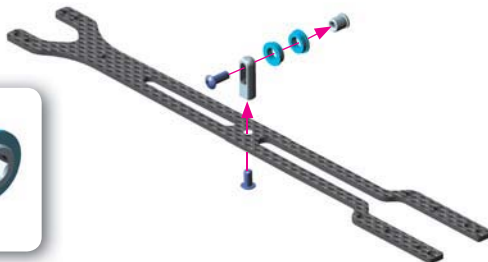

DETAIL



902306  
SH M3x6

L=R

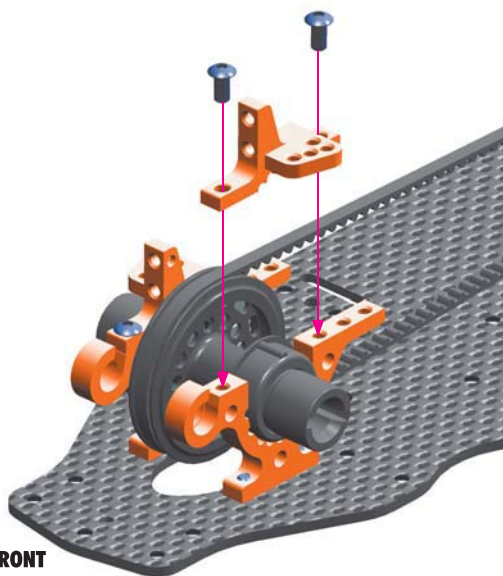

FRONT

L=R

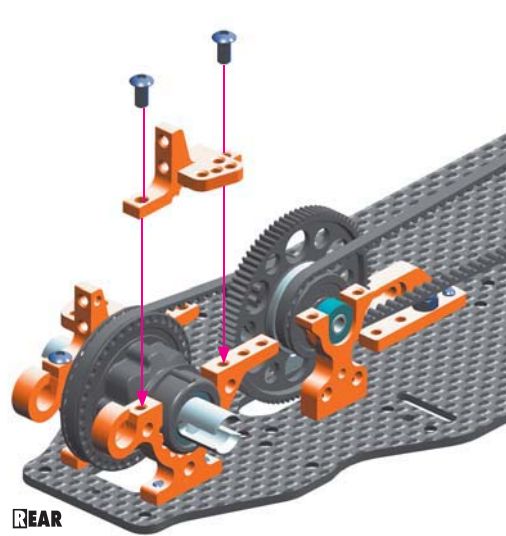

REAR



902306  
SH M3x6

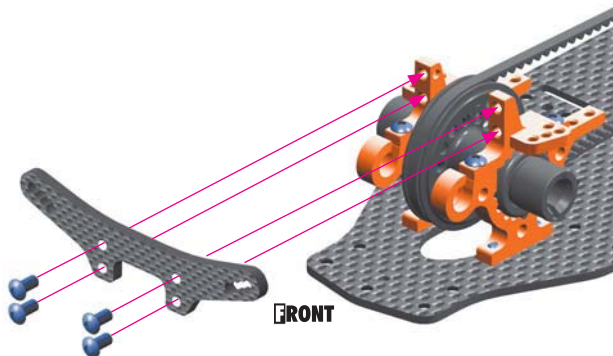

FRONT

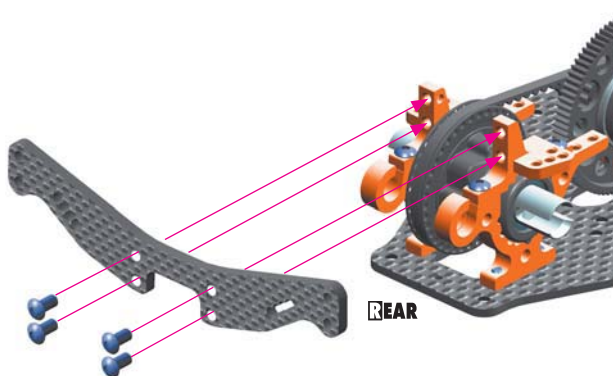

REAR

# 3. FRONT & REAR SUSPENSION

**#307217**  
TITAN SUSPENSION PIVOT PIN (2)  
OPTION

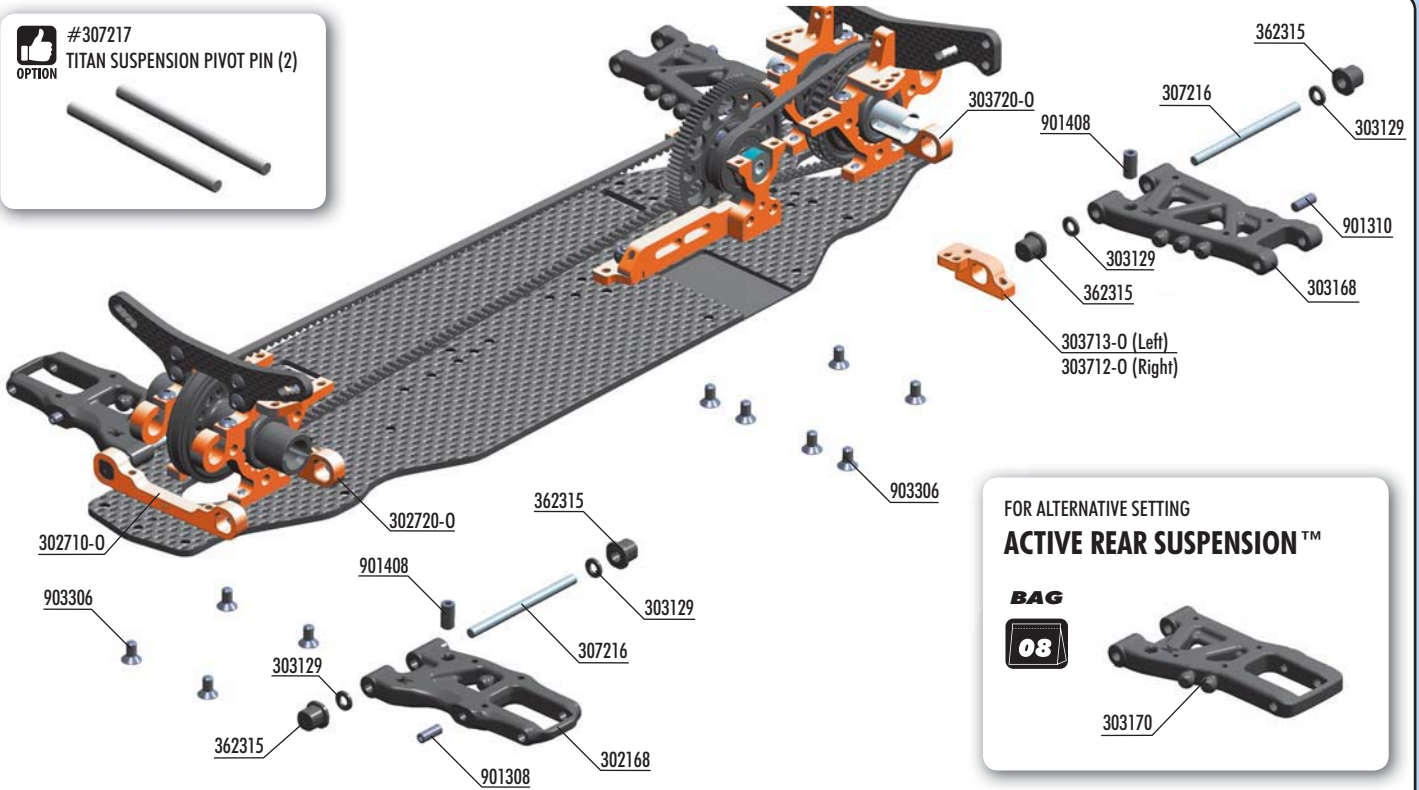

FOR ALTERNATIVE SETTING  
**ACTIVE REAR SUSPENSION™**

**BAG**



For better stability and to make the car easier to drive, optional #302190 and #303190 graphite stiffeners may be used. Using only 4 screws, the graphite stiffener can be installed or removed which would completely change the characteristics of the car. Stiffeners may be used independently at front and/or rear. **IMPORTANT!** Install/remove stiffeners equally on left & right sides.

**#30 2190**  
GRAPHITE FRONT LOWER ARM PLATE 1.6MM (2)

**2x** **L=R** 2.5x6mm

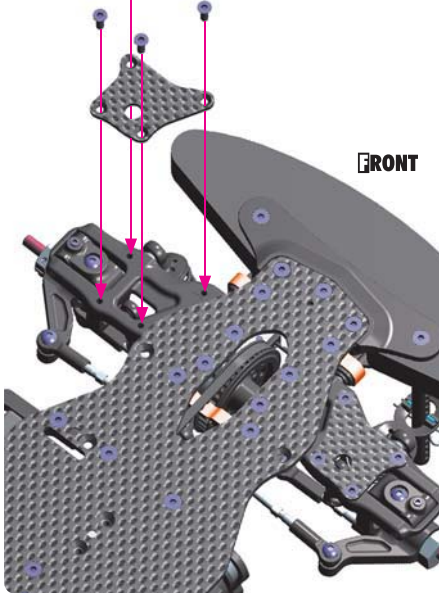

**#30 3190**  
GRAPHITE REAR LOWER ARM PLATE 1.6MM (2)

**2x** **L=R** 2.5x6mm

**STANDARD REAR SUSPENSION**

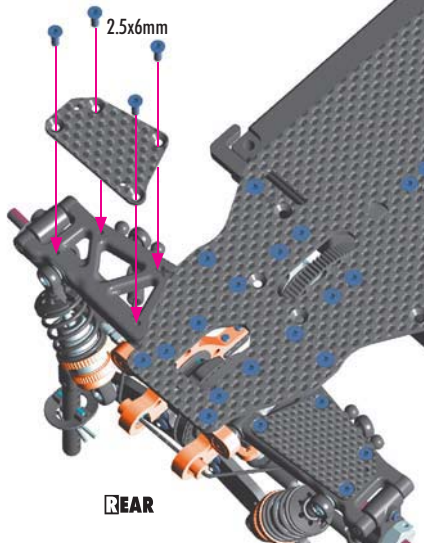

**#30 3192**  
ARS GRAPHITE REAR LOWER ARM PLATE 1.6MM (2)

**2x** **L=R** 2.5x6mm

**ACTIVE REAR SUSPENSION™**

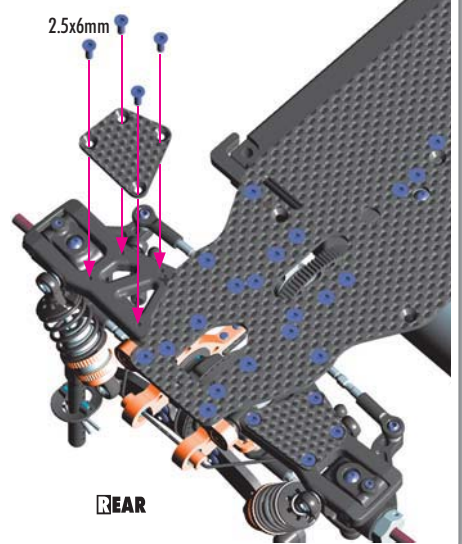

**BAG**

**03**

- |           |   |           |  |
|-----------|---|-----------|--|
| 30 2168   | FRONT SUSPENSION ARM - HARD - 1-HOLE                          | 30 3192   | ARS GRAPHITE REAR LOWER ARM PLATE 1.6MM (2) (OPTION)           |
| 30 2169   | FRONT SUSPENSION ARM - GRAPHITE - 1-HOLE (OPTION)             | 303712-0  | ALU LOWER 2-PIECE SUSPENSION HOLDER - RIGHT                    |
| 30 2190   | GRAPHITE FRONT LOWER ARM PLATE 1.6MM (2) (OPTION)             | 303713-0  | ALU LOWER 2-PIECE SUSPENSION HOLDER - LEFT                     |
| 30 2710-0 | ALU FRONT LOWER 1-PIECE SUSPENSION HOLDER - FRONT - FF        | 30 3711-0 | ALU REAR LOWER 1-PIECE SUSPENSION HOLDER - FRONT - RF (OPTION) |
| 30 2720-0 | ALU FRONT LOWER 1-PIECE SUSPENSION HOLDER - REAR - FR         | 30 3720-0 | ALU REAR LOWER 1-PIECE SUSPENSION HOLDER - REAR - RR           |
| 30 3129   | COMPOSITE SET OF WHEELBASE SHIMS (3x1MM; 1x2MM) (2)           | 30 7216   | SUSPENSION PIVOT PIN (2)                                       |
| 30 3168   | REAR SUSPENSION ARM - HARD - 1-HOLE                           | 36 2315   | ECCENTRIC BUSHING SET (2)                                      |
| 30 3169   | REAR SUSPENSION ARM - GRAPHITE - 1-HOLE (OPTION)              | 90 1308   | HEX SCREW SB M3x8 (10)   |
| 30 3170   | ARS - ACTIVE REAR SUSPENSION ARM - HARD - 1-HOLE              | 90 1310   | HEX SCREW SB M3x10 (10)  |
| 30 3171   | ARS - ACTIVE REAR SUSPENSION ARM - GRAPHITE - 1-HOLE (OPTION) | 90 1408   | HEX SCREW SB M4x8 (10)   |
| 30 3190   | GRAPHITE REAR LOWER ARM PLATE 1.6MM (2) (OPTION)              | 90 3306   | HEX SCREW SFH M3x6 (10)  |



# 3. FRONT & REAR SUSPENSION



901310  
SB M3x10



901408  
SB M4x8

## 2x L-R REAR ARMS

### STANDARD REAR SUSPENSION

INITIAL SETTING

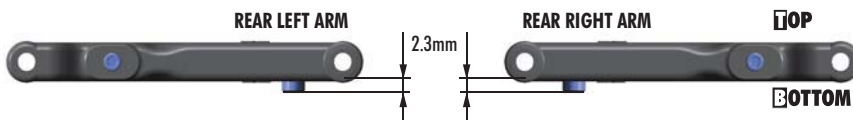

#303169 GRAPHITE ARM - REAR  
More traction and more stable but more fragile  
(recommended for all kinds of conditions)



## 2x L-R ACTIVE REAR SUSPENSION™

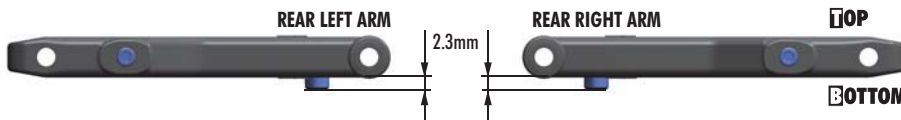

#303171 GRAPHITE ARS ARM - REAR  
More traction and more stable but more fragile  
(recommended for all kinds of conditions)



REAR DOWNSTOP  
ADJUSTMENT



901308  
SB M3x8



901408  
SB M4x8

## 2x L-R FRONT ARMS

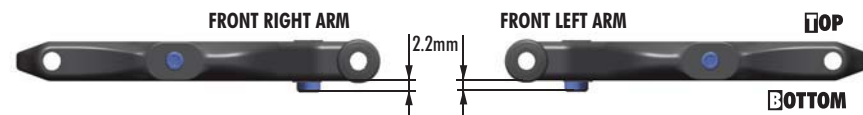

#302169 GRAPHITE ARM - FRONT  
More traction and more stable but more fragile  
(recommended for all kinds of conditions)



FRONT DOWNSTOP  
ADJUSTMENT

# 3. FRONT & REAR SUSPENSION



903306  
SFH M3x6

**FRONT**

Marked "FR"

**NOTE ORIENTATION**

**#303710-0**  
ALU LOWER 2-PIECE SUSPENSION HOLDER

**OPTION**

For more steering, we recommend using the optional alu separate suspension holders.



303129  
SHIM 3x6x1



903306  
SFH M3x6

**#303711-0**  
ALU REAR LOWER 1-PIECE SUSPENSION HOLDER

**OPTION**

Marked "RF"

For more steering, we recommend using the optional 1-piece alu suspension holder. Use for high-grip conditions only; it decreases rear traction.

**IMPORTANT**  
When using ARS suspension, the alu rear lower 1 piece suspension holder must be used together with #302201 alu brace post for ARS 3x5x9mm (2).

**NOTE ORIENTATION**

It is extremely important that the arms move freely on the pivot pins. If they do not, use the #107633 HUDY Arm Reamer to slightly resize the holes in the arms.

**INITIAL POSITION**

1 0.5 0 0.5 1

Composite eccentric bushings

**ALTERNATIVE STANDARD REAR SUSPENSION INITIAL SETTING**

**ALTERNATIVE ACTIVE REAR SUSPENSION™**

44.3 mm

**2x 1:1 L=R**

**INITIAL POSITION**

1 0.5 0 0.5 1

Composite eccentric bushings

All possible mounting alternatives of eccentric bushings

**ECCENTRIC BUSHINGS HAVE TWO DIFFERENT OFFSETS FROM THE CENTER.**

● ● Middle position = 0.5 mm or 0.5° from center    ● ● Outer position = 1mm or 1° from center

The XRAY rear alu lower suspension holders provide even greater range of adjustment for the rear suspension. Using different combinations of eccentric bushings, fine adjustment of rear squat, rear toe-in, rear roll center, and rear track-width can be obtained. For more information about the influence of rear squat, rear toe-in, rear roll center and rear track-width on car handling, please refer to HUDY Set-up Book (#209100).

**SET-UP BOOK**

TOE-IN  
TRACK-WIDTH  
WHEELBASE  
ROLL CENTER  
ANTI-SQUAT  
PRO-SQUAT



# 3. FRONT & REAR SUSPENSION

10

303129  
SHIM 3x6x1



903306  
SFH M3x6



It is extremely important that the arms move freely on the pivot pins. If they do not, use the #107633 HUDY Arm Reamer to slightly resize the holes in the arms.



Marked "FF"

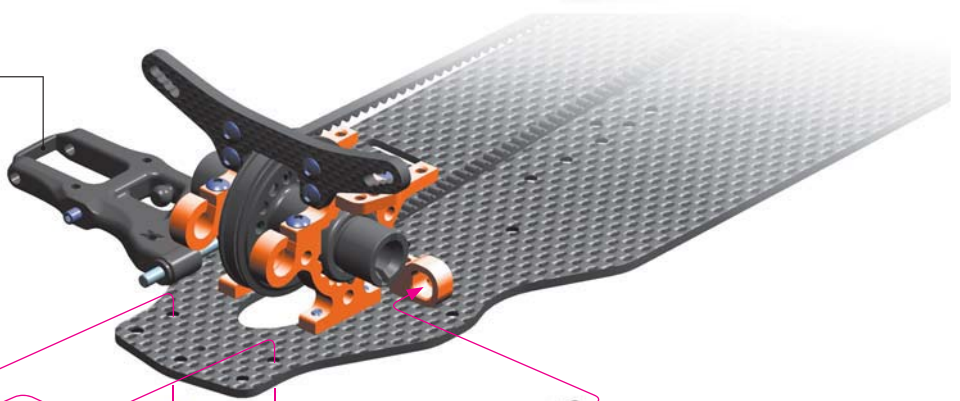

FRONT

3x6x1mm

3x6x1mm

INITIAL POSITION

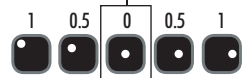

Composite eccentric bushings

INITIAL POSITION



Composite eccentric bushings

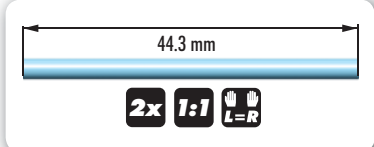

All possible mounting alternatives of eccentric bushings

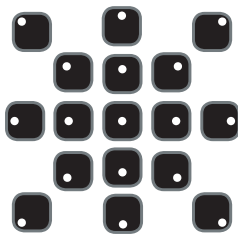

ECCENTRIC BUSHINGS HAVE TWO DIFFERENT OFFSETS FROM THE CENTER.

Middle position = 0.5 mm or 0.5° from center

Outer position = 1 mm or 1° from center

The XRAY front alu lower suspension holders provide even greater range of adjustment for the front suspension. Using different combinations of eccentric bushings, fine adjustment of front anti-squat, front kick-up, front toe-in, front roll center, and front track-width can be obtained. For more information about the influence of front anti-dive, front kick-up, front toe-in, front roll center and front track-width on car handling, please refer to HUDY Set-up Book (#209100).



TOE-IN  
TRACK-WIDTH  
WHEELBASE  
ROLL CENTER  
ANTI-DIVE  
KICK-UP

# 4. STEERING

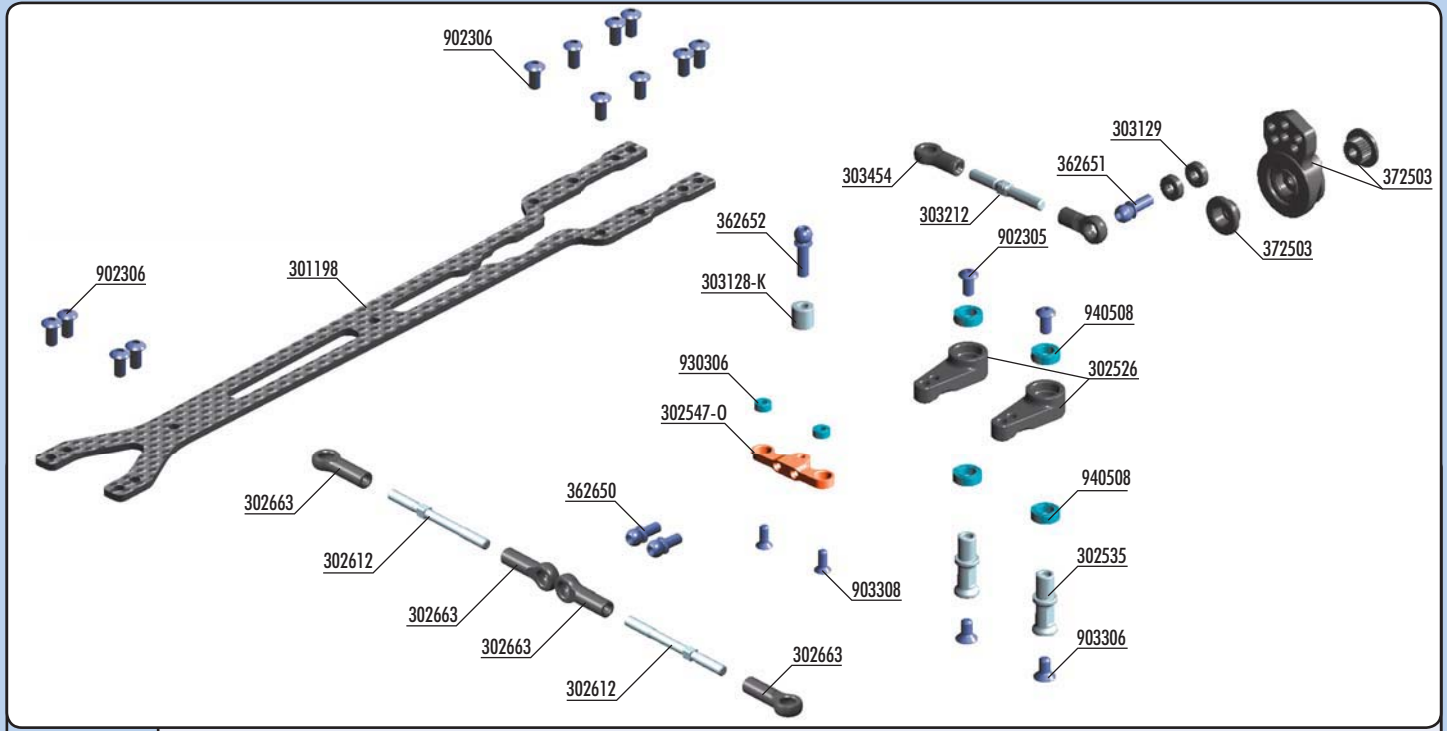

**BAG**  
**04**

- |           |  |         |   |
|-----------|--|---------|---|
| 30 1196   | T4 UPPER DECK 1.6MM GRAPHITE - V2 (OPTION)                   | 36 2650 | BALL END 4.9MM WITH THREAD 6MM (2)                |
| 30 1198   | T4 UPPER DECK 2.0MM GRAPHITE                                 | 36 2651 | BALL END 4.9MM WITH THREAD 8MM (2)                |
| 30 2525   | ALU DUAL SERVO SAVER ARM + BALL-BEARINGS (2) (OPTION)        | 36 2652 | BALL END 4.9MM WITH THREAD 10MM (2)               |
| 30 2526   | COMPOSITE DUAL SERVO SAVER ARM                               | 37 2503 | COMPOSITE SERVO SAVER - X-STIFF - SET - V2        |
| 30 2535   | ALU STEERING POST FOR DUAL SERVO SAVER (2)                   | 90 2305 | HEX SCREW SH M3x5 (10)                            |
| 30 2547-0 | T4*14 ALU STEERING PLATE 8.5MM FOR DUAL SERVO SAVER - ORANGE | 90 2306 | HEX SCREW SH M3x6 (10)                            |
| 30 2612   | ALU ADJ. TURNBUCKLE M3 L/R 39 MM - SWISS 7075 T6 (2)         | 90 3306 | HEX SCREW SFH M3x6 (10)                           |
| 30 2663   | COMPOSITE BALL JOINT 5 MM - OPEN - V2 (8)                    | 90 3308 | HEX SCREW SFH M3x8 (10)                           |
| 30 3128-K | ALU SHIM 3x6x6.0MM - BLACK (10)                              | 93 0306 | BALL-BEARING 3x6x2.5 (2)                          |
| 30 3129   | COMPOSITE SET OF SHIMS (3x1MM; 1x2MM) (2)                    | 94 0508 | HIGH-SPEED BALL-BEARING 5x8x2.5 RUBBER SEALED (2) |
| 30 3212   | ALU ADJ. TURNBUCKLE L/R 26 MM - SWISS 7075 T6 (2)            |         |   |
| 30 3454   | BALL JOINT 4.9MM - OPEN (4)                                  |         |   |



**2x** **L-R**

**LEFT** **RIGHT**

65.4mm

approximately 47mm

**SERVO LINK**  
Adjust servo link to fit your servo

- 903308 SFH M3x8
- 930306 BB 3x6x2.5
- 940508 BB 5x8x2.5



**Use bearing oil for all bearings (HUDEY #106230)**

**#302525 ALU DUAL SERVO SAVER ARM**  
OPTION

We recommend using the aluminum dual servo saver arms when better steering response is needed. Also recommended for asphalt tracks.

**Tighten the screws gently but fully, and then loosen 1/3 turn so the composite dual servo saver moves freely.**

**NOTE ORIENTATION**

Do not use for basic set-up

6mm THREAD

**NOTE ORIENTATION**

**2x** **L-R**

**TIP**

To change Ackermann angle, use 2 identical shims (of same thickness) between the alu steering plate and ball ends.

3x1mm & 1x2mm composite shims





303129  
SHIM 3x6x2



303128-K  
SHIM 3x6x6

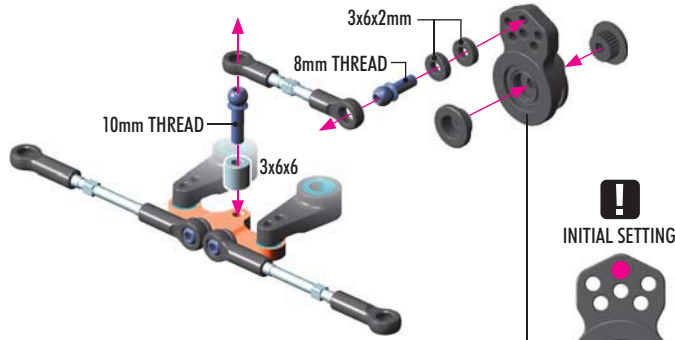

OPTION

### HUDY ALU SERVO HORNS

|         |                                      |
|---------|--------------------------------------|
| #293491 | KO, JR, Sanwa, Airtr. - OFFSET - 23T |
| #293492 | Hiitec - OFFSET - 24T                |
| #293493 | Futaba - OFFSET - 25T                |

|         |                                 |
|---------|---------------------------------|
| #293501 | KO, JR, Sanwa, Airtronics - 23T |
| #293502 | Hiitec - 24T                    |
| #293503 | Futaba - 25T                    |

For more in-corner steering and better steering response, aluminum servo horns may be used.

### IMPORTANT!

When the aluminum horn is used, the steering servo saver is not used. This increases the risk of breaking the servo in serious crashes.

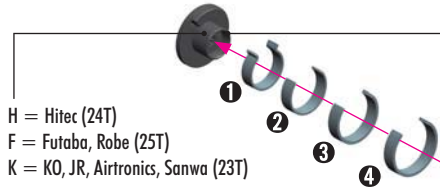

H = Hiitec (24T)  
F = Futaba, Robe (25T)  
K = KO, JR, Airtronics, Sanwa (23T)

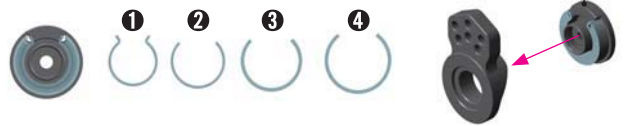

902305  
SH M3x5



903306  
SFH M3x6



902306  
SH M3x6

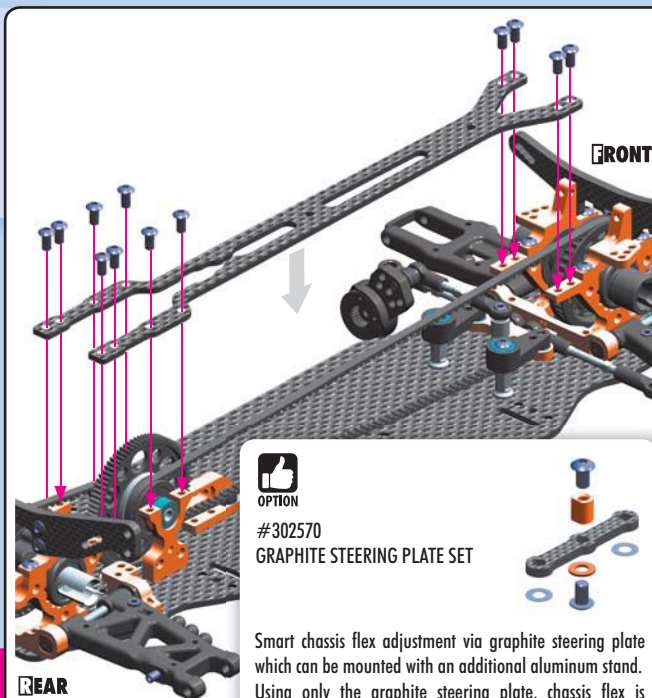

OPTION

### #302570 GRAPHITE STEERING PLATE SET

Smart chassis flex adjustment via graphite steering plate which can be mounted with an additional aluminum stand. Using only the graphite steering plate, chassis flex is medium; using the aluminum stand for reinforcement, the flex becomes stiffer. Stiffer flex results in more aggressive handling and increased steering.



OPTION

### #301196 T4 GRAPHITE UPPER DECK 1.6MM - V2



We recommend using optional 1.6mm top deck for super-low traction conditions as it provides more overall traction and steering.



OPTION

### #306516-0 T4 ALU TOP DECK MOUNT - ORANGE

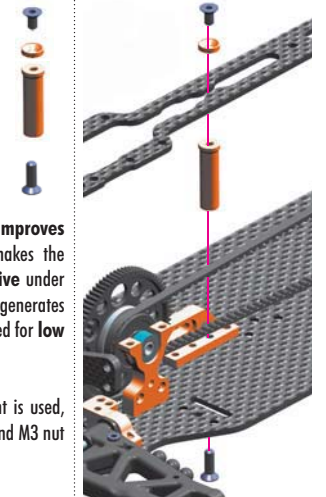

Optional alu top deck mount improves forward and rear traction and makes the car more stable and easier to drive under low-traction conditions, however generates more on-power push. Recommended for low and medium traction conditions.

When the aluminum top deck mount is used, the screws from layshaft bulkheads and M3 nut from motor holder must be removed.



CHASSIS FLEX SETTING  
TOP DECK SETTING

# 5. FRONT & REAR TRANSMISSION

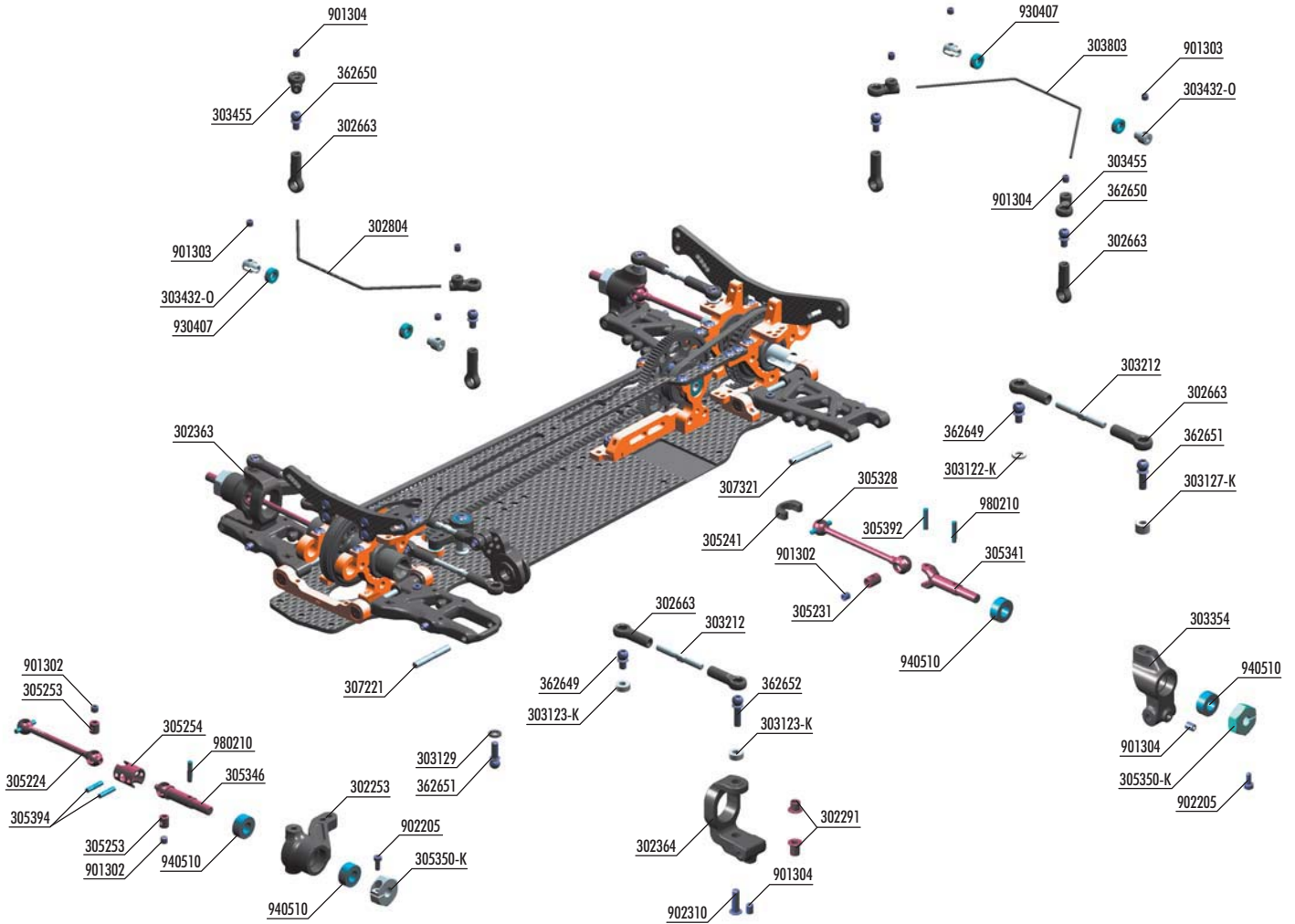

FOR ALTERNATIVE SETTING

## ACTIVE REAR SUSPENSION™

**BAG**

**08**



#307222 - TITAN FRONT ARM PIVOT PIN (2)

#307322 - TITAN REAR ARM PIVOT PIN (2)



**BAG**

**05**

- |           |  |           |  |
|-----------|--|-----------|--|
| 30 2253   | COMPOSITE STEERING BLOCK - HARD                                | 30 5332   | ECS ES (ES) DRIVE SHAFT 52MM - HUDY SPRING STEEL™ - SET          |
| 30 2291   | STEEL STEERING BUSHING (2+2)                                   | 30 5333   | ECS ES (ES) DRIVE SHAFT 50MM - HUDY SPRING STEEL™ - SET (OPTION) |
| 30 2363   | COMPOSITE C-HUB RIGHT - 4° DEG. - MEDIUM - V2                  | 30 5346   | ECS DRIVE AXLE FOR 2MM PIN - HUDY SPRING STEEL™                  |
| 30 2364   | COMPOSITE C-HUB LEFT - 4° DEG. - MEDIUM - V2                   | 30 5394   | ECS DRIVE SHAFT PIN 2 x 9 WITH FLAT SPOT (2)                     |
| 30 2369   | COMPOSITE C-HUB RIGHT - 0° DEG. - HARD                         | 30 5341   | DRIVE AXLE - LIGHTWEIGHT - HUDY SPRING STEEL™                    |
| 30 2370   | COMPOSITE C-HUB LEFT - 0° DEG. - HARD                          | 30 5350-K | ALU WHEEL HUB - BLACK (2)  |
| 30 2663   | COMPOSITE BALL JOINT 4.9MM - OPEN - V2 (8)                     | 30 5392   | DRIVE SHAFT PIN 2 x 10 WITH FLAT SPOT (2)                        |
| 30 2804   | ANTI-ROLL BAR FOR BALL BEARINGS - FRONT 1.4 MM                 | 30 7221   | FRONT ARM PIVOT PIN (2)  |
| 30 3122-K | ALU SHIM 3x6x1.0MM - BLACK (10)                                | 30 7321   | REAR ARM PIVOT PIN (2)   |
| 30 3123-K | ALU SHIM 3x6x2.0MM - BLACK (10)                                | 36 2649   | BALL END 4.9MM WITH THREAD 5MM (2)                               |
| 30 3127-K | ALU SHIM 3x6x4.0MM - BLACK (10)                                | 36 2650   | BALL END 4.9MM WITH THREAD 6MM (2)                               |
| 30 3129   | COMPOSITE SET OF SHIMS (3x1MM; 1x2MM) (2)                      | 36 2651   | BALL END 4.9MM WITH THREAD 8MM (2)                               |
| 30 3210   | TURNBUCKLE M3 L/R 26 MM - SPRING STEEL™ (2) (OPTION)           | 36 2652   | BALL END 4.9MM WITH THREAD 10MM (2)                              |
| 30 3212   | ALU ADJ. TURNBUCKLE M3 L/R 26 MM - SWISS 7075 T6 (2)           | 90 1302   | HEX SCREW SB M3x2.5 (10)   |
| 30 3354   | COMPOSITE UPRIGHT 0° OUTBOARD TOE-IN - HARD                    | 90 1303   | HEX SCREW SB M3x3 (10)   |
| 30 3432-0 | ALU ANTI-ROLL BAR BUSHING - ORANGE (2)                         | 90 1304   | HEX SCREW SB M3x4 (10)   |
| 30 3455   | COMPOSITE ANTI-ROLL BAR BALL JOINT 4.9 MM (4)                  | 90 2205   | HEX SCREW SH M2x5 (10)   |
| 30 3803   | ANTI-ROLL BAR FOR BALL BEARINGS - REAR 1.3 MM                  | 90 2310   | HEX SCREW SH M3x10 (10)  |
| 30 5231   | DRIVE SHAFT COUPLING - HUDY SPRING STEEL™                      | 93 0407   | BALL-BEARING 4x7x2.5 (2)   |
| 30 5241   | DRIVE SHAFT REPLACEMENT PLASTIC CAP 3.5 MM (4)                 | 94 0510   | HIGH-SPEED BALL-BEARING 5x10x4 RUBBER SEALED (2)                 |
| 30 5224   | ECS (ES) DRIVE SHAFT 52MM FOR 2MM PIN - HUDY SPRING STEEL™ (1) | 98 0210   | PIN 2x10 (10)  |
| 30 5253   | ECS DRIVE SHAFT COUPLING FOR 2MM PIN - HUDY SPRING STEEL™      |           |  |
| 30 5254   | ECS (ES) DRIVE SHAFT CASE FOR 2MM PIN - HUDY SPRING STEEL™     |           |  |
| 30 5328   | ALU DRIVE SHAFT SWISS 7075 T6 - HARD COATED - 50MM             |           |  |



# 5. FRONT & REAR TRANSMISSION



901302  
SB M3x2.5



305392  
P 2x10

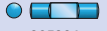

305394  
P 2x9

## 2x REAR TRANSMISSION

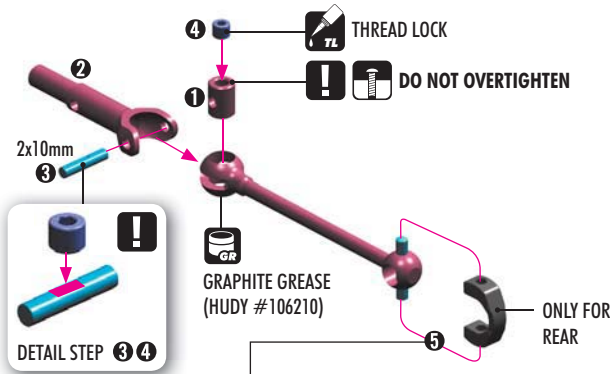

**TIP** For easy installation of the #305241 plastic caps, use pliers as shown.

## 2x FRONT TRANSMISSION

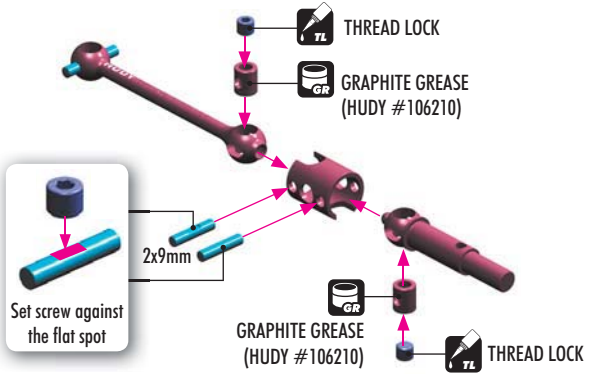

### ECS DRIVE SHAFTS

ECS shafts are available in both 50mm (optionally) and 52mm lengths. The ECS drive shafts were developed to decrease front wheel vibration when racing with a solid front axle, thus providing a much smoother and quieter ride and increased steering.

Longer drive shafts (52mm) make the car easier to drive because they give more traction and better stability, mainly in chicanes. However, the car will understeer more than with shorter (50mm) shafts which give a lot of steering and make the car more aggressive.

Both left & right shafts should ALWAYS be the same length at one end of the car (front or rear).

52mm shafts are recommended for **carpet and large asphalt** tracks.

50mm shafts are recommended for **small-medium tight asphalt** tracks.



### DRIVE SHAFTS

| OPTION  | DRIVE SHAFTS |
|---------|--------------|
| #305323 | 50MM - STEEL |
| #305324 | 52MM - STEEL |
| #305326 | 52MM - ALU   |
| #305328 | 50MM - ALU   |
| #305332 | 52MM - ECS   |
| #305333 | 50MM - ECS   |

## L-R REAR TRANSMISSION

### ALTERNATIVE STANDARD REAR SUSPENSION INITIAL SETTING

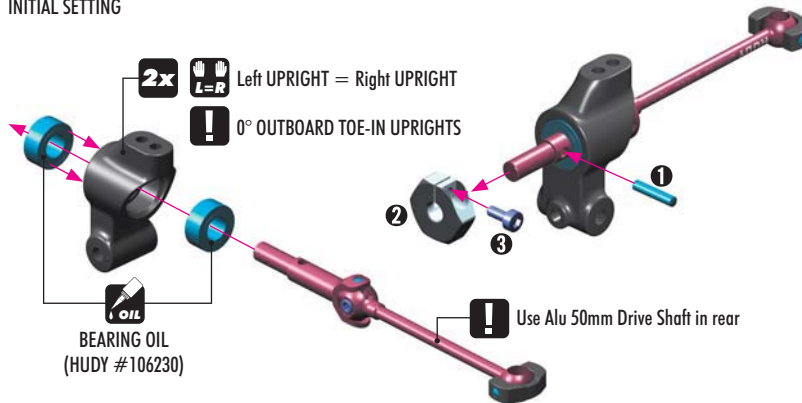

### ALTERNATIVE ACTIVE REAR SUSPENSION™

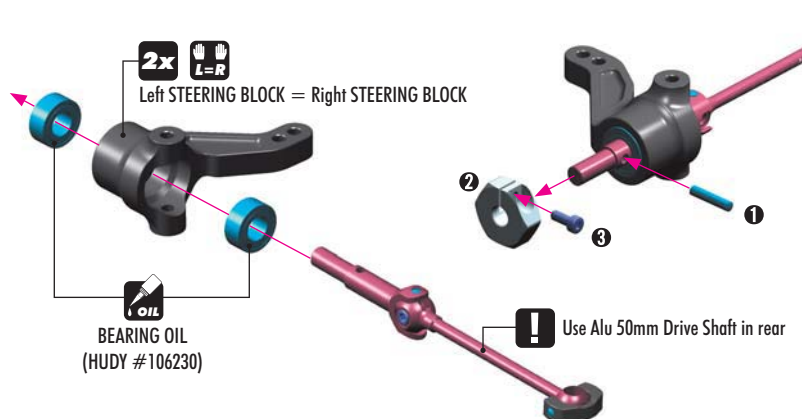

## T4 OPTIONAL PARTS

| STANDARD | UPRIGHTS                         |
|----------|----------------------------------|
|          | #303351 1° - R MEDIUM (2-HOLE)   |
|          | #303352 0° - R/L MEDIUM (2-HOLE) |
|          | #303353 1° - R HARD (2-HOLE)     |
|          | #303354 0° - R/L HARD (2-HOLE)   |
|          | #303361 1° - L MEDIUM (2-HOLE)   |
|          | #303362 0° - R/L MEDIUM (1-HOLE) |
|          | #303363 1° - L HARD (2-HOLE)     |
|          | #303364 0° - R/L HARD (1-HOLE)   |
|          | #303358 ALU 1° - R/L (4-HOLE)    |
|          | #303359 ALU 2° - R/L (4-HOLE)    |

| STANDARD | WHEEL HUBS                      |
|----------|---------------------------------|
|          | #305350-K ALU - OFFSET (0 mm)   |
|          | #305351 ALU - OFFSET (-0.75 mm) |
|          | #305352 ALU - OFFSET (+0.75 mm) |
|          | #305353 ALU - OFFSET (+1.5 mm)  |

| STANDARD | STEERING BLOCKS |
|----------|-----------------|
|          | #302252 MEDIUM  |
|          | #302253 HARD    |
|          | #302256 ALU     |



902205  
SH M2x5

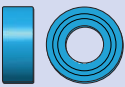

940510  
BB 5x10x4



980210  
P 2x10



REAR TOE-IN  
TRACK-WIDTH

# 5. FRONT & REAR TRANSMISSION



902205  
SH M2x5



940510  
BB 5x10x4



980210  
P 2x10



REAR TOE-IN  
TRACK-WIDTH

## 2x FRONT TRANSMISSION

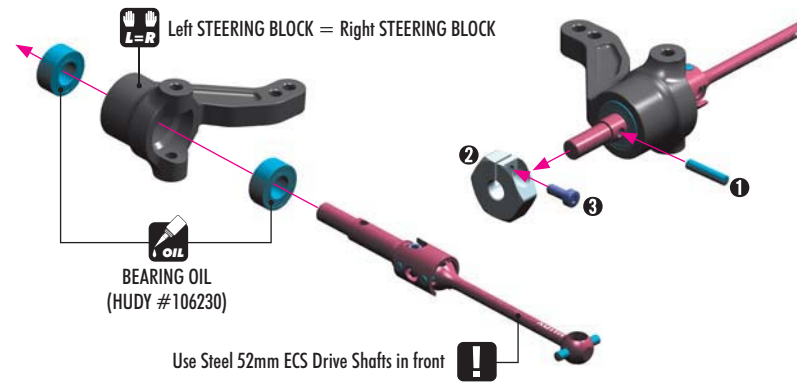

## T4 OPTIONAL PARTS

| WHEEL HUBS |                               |
|------------|-------------------------------|
| STANDARD   | #305350-K ALU - OFFSET 0 MM   |
|            | #305351 ALU - OFFSET -0.75 MM |
|            | #305352 ALU - OFFSET +0.75 MM |
|            | #305353 ALU - OFFSET +1.5 MM  |

| STEERING BLOCKS |                |
|-----------------|----------------|
|                 | #302252 MEDIUM |
| STANDARD        | #302253 HARD   |
|                 | #302256 ALU    |



902310  
SH M3x10



CASTER ADJUSTMENT

## 2x FRONT TRANSMISSION

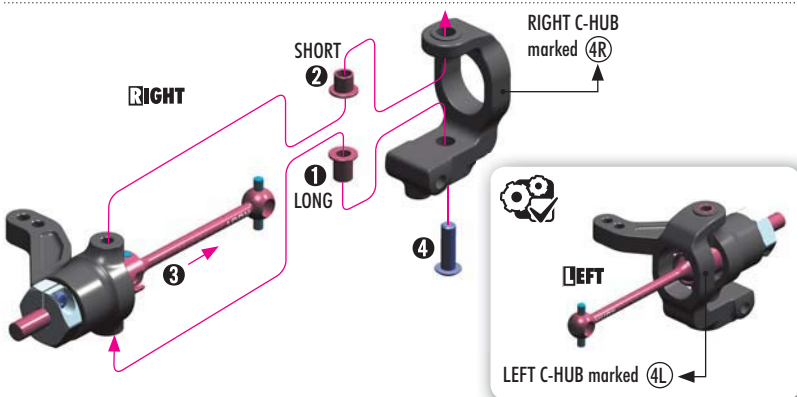

## 2x ACTIVE REAR SUSPENSION™

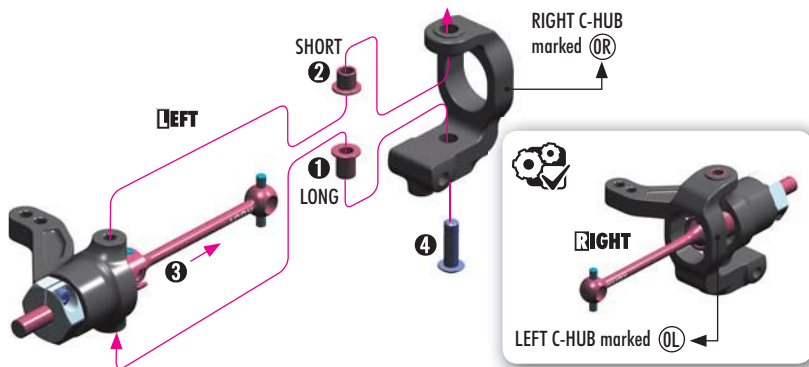

| C-HUBS FRONT TRANSMISSION |                               |
|---------------------------|-------------------------------|
|                           | #302334 ALU 0° - R + L        |
|                           | #302335 ALU 2° - RIGHT        |
|                           | #302336 ALU 2° - LEFT         |
|                           | #302337 ALU 4° - RIGHT        |
|                           | #302338 ALU 4° - LEFT         |
|                           | #302339 ALU 6° - RIGHT        |
|                           | #302340 ALU 6° - LEFT         |
|                           | #302361 2° - RIGHT - MEDIUM   |
|                           | #302362 2° - LEFT - MEDIUM    |
| STANDARD                  | #302363 4° - RIGHT - MEDIUM   |
| STANDARD                  | #302364 4° - LEFT - MEDIUM    |
|                           | #302365 6° - RIGHT - MEDIUM   |
|                           | #302366 6° - LEFT - MEDIUM    |
|                           | #302371 2° - RIGHT - HARD     |
|                           | #302372 2° - LEFT - HARD      |
|                           | #302373 4° - RIGHT - HARD     |
|                           | #302374 4° - LEFT - HARD      |
|                           | #302375 6° - RIGHT - HARD     |
|                           | #302376 6° - LEFT - HARD      |
|                           | #302383 4° - RIGHT - GRAPHITE |
|                           | #302384 4° - LEFT - GRAPHITE  |

| C-HUBS ACTIVE REAR TRANSMISSION |                               |
|---------------------------------|-------------------------------|
|                                 | #302334 ALU 0°                |
|                                 | #302359 0° - RIGHT - MEDIUM   |
|                                 | #302360 0° - LEFT - MEDIUM    |
| STANDARD                        | #302369 0° - RIGHT - HARD     |
| STANDARD                        | #302370 0° - LEFT - HARD      |
|                                 | #302379 0° - RIGHT - GRAPHITE |
|                                 | #302380 0° - LEFT - GRAPHITE  |

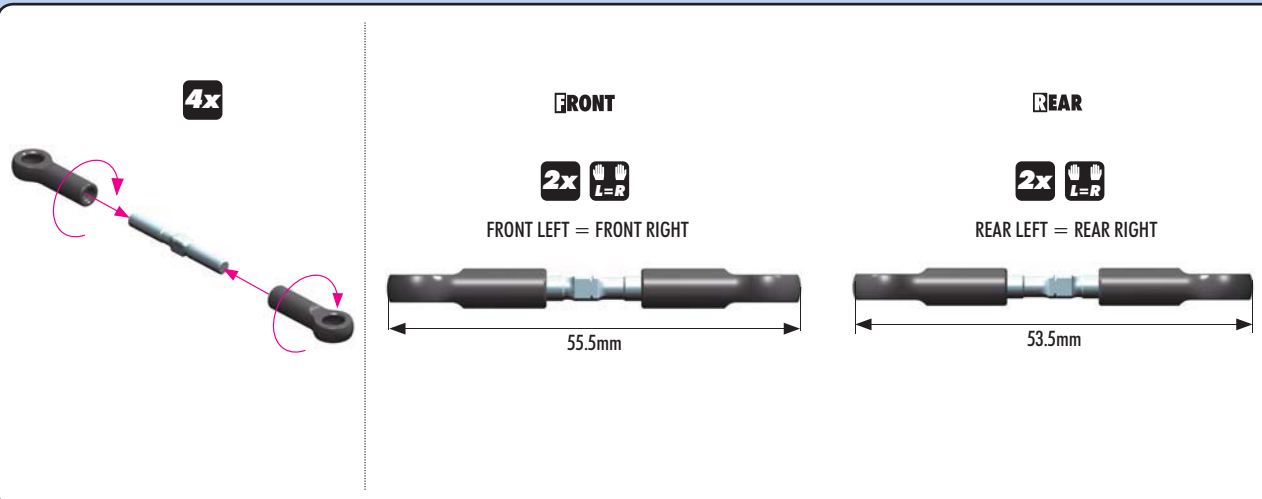

CAMBER ADJUSTMENT



# 5. FRONT & REAR TRANSMISSION



303122-K  
SHIM 3x6x1



303127-K  
SHIM 3x6x4



901304  
SB M3x4

## REAR TRANSMISSION

### ALTERNATIVE STANDARD REAR SUSPENSION INITIAL SETTING

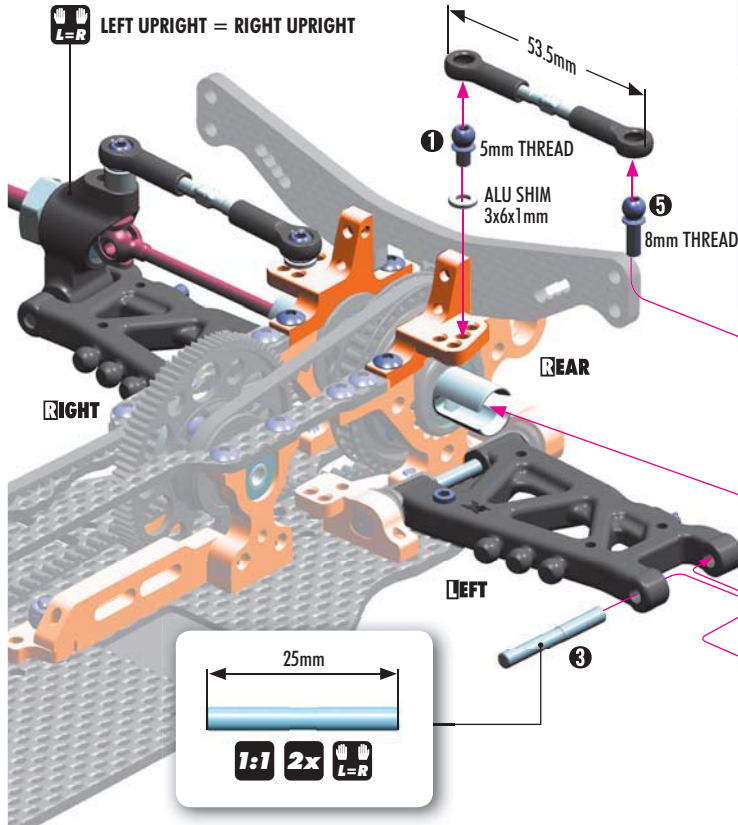

INITIAL POSITION

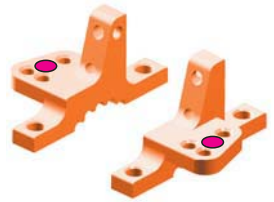

1-HOLE REAR UPRIGHTS (See page 19)

OPTION

An optional 1-hole rear upright is available for fine tuning. This optional upright may be used on high-traction tracks or tracks with long sweepers, since the position of the center hole will allow faster driving through those corners because of better cornering speed.

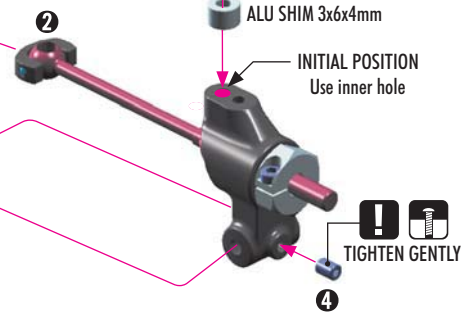

### ALTERNATIVE ACTIVE REAR SUSPENSION™

#### STEP 1

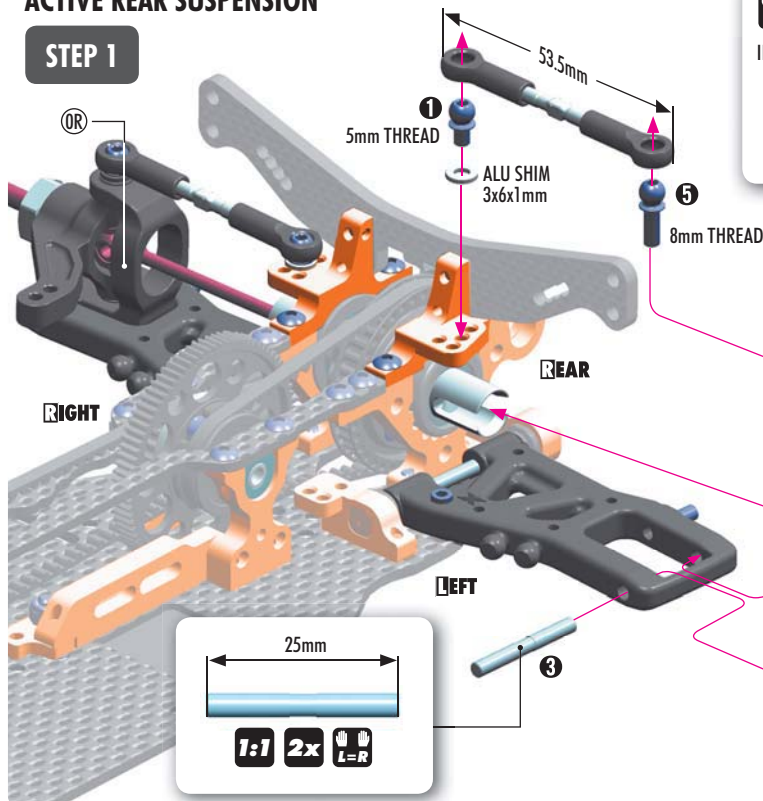

INITIAL POSITION

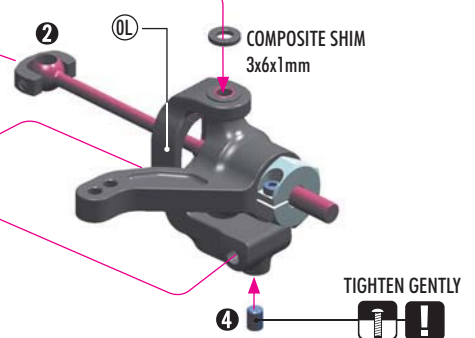
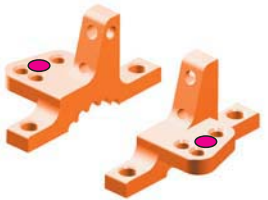

ROLL CENTER  
CAMBER

# 5. FRONT & REAR TRANSMISSION

10

303129  
SHIM 3x6x1



903306  
SFH M3x6

## 2x L=R REAR TRANSMISSION

### ALTERNATIVE ACTIVE REAR SUSPENSION™

#### STEP 2

#### INITIAL POSITION



#### ! IMPORTANT

ALWAYS USE ONLY THIS POSITION

#### ! IMPORTANT



The angle of ARS linkage – which is made by adding/removing shims on the steering block and ARS post mount – changes the toe-in characteristics of the rear tires under rolling effect; when the car is pressed the toe-in can either increase or decrease.

Check the toe-in change on your set-up system when the car is in neutral position and when is pressed down. For more information see the HUDY Set-Up Book.

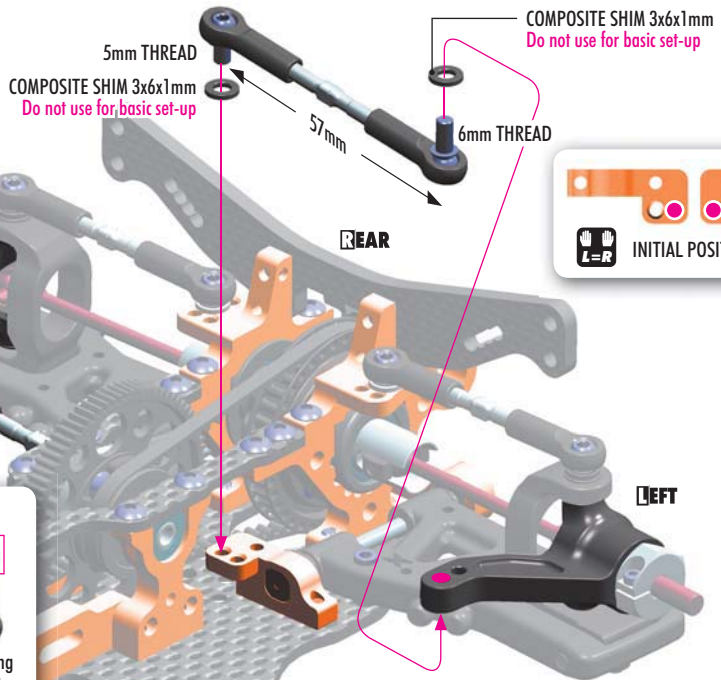

ACTIVE TOE-IN

303123-K  
SHIM 3x6x2



901304  
SB M3x4

## 2x L=R FRONT TRANSMISSION

4R

5mm THREAD

ALU SHIM 3x6x2mm

55.5mm

1

5

10mm THREAD

RIGHT

FRONT

LEFT

3

L=R 2x  
INITIAL POSITION



4L

ALU SHIM 3x6x2mm

4

! TIGHTEN GENTLY



1:1 2x L=R



ROLL-CENTER

# 5. FRONT & REAR TRANSMISSION

10

303129  
SHIM 3x6x1

## FRONT TRANSMISSION

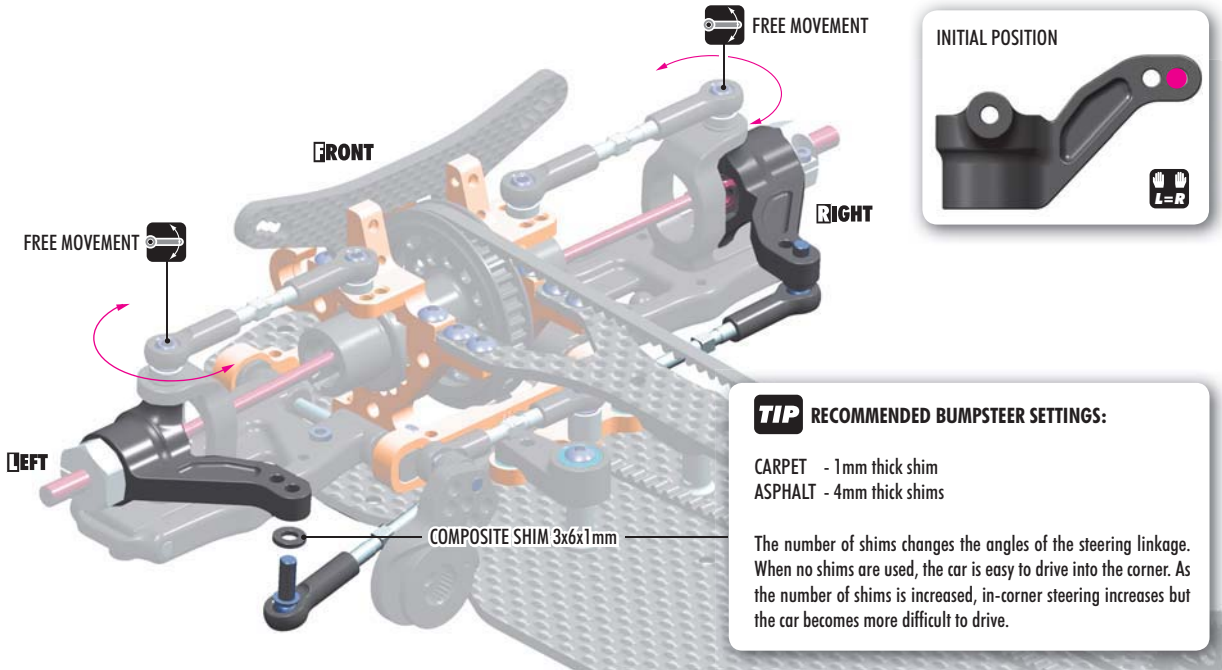

**TIP** RECOMMENDED BUMPSTEER SETTINGS:

CARPET - 1mm thick shim  
ASPHALT - 4mm thick shims

The number of shims changes the angles of the steering linkage. When no shims are used, the car is easy to drive into the corner. As the number of shims is increased, in-corner steering increases but the car becomes more difficult to drive.



4x

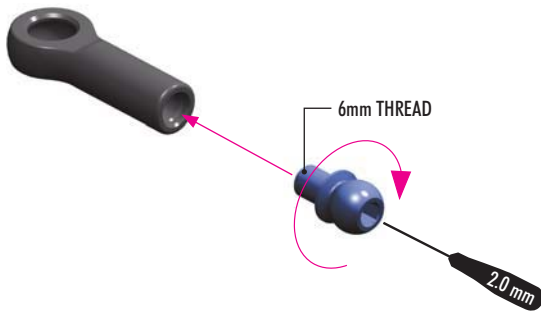

4x

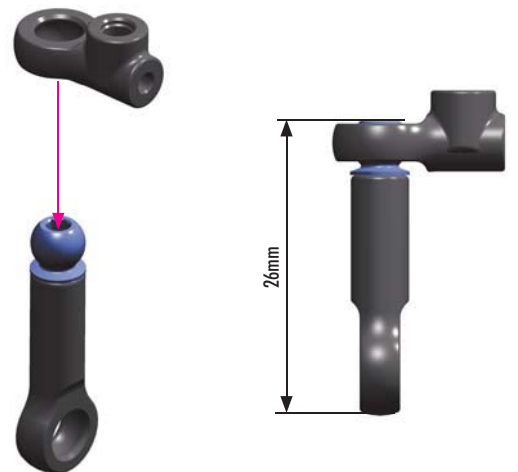

2x



| FRONT ANTI-ROLL BARS |         |              |
|----------------------|---------|--------------|
| OPTION               | #302802 | FRONT 1.2 MM |
|                      | #302803 | FRONT 1.3 MM |
| STANDARD             | #302804 | FRONT 1.4 MM |
|                      | #302805 | FRONT 1.5 MM |
|                      | #302806 | FRONT 1.6 MM |

| REAR ANTI-ROLL BARS |         |             |
|---------------------|---------|-------------|
| OPTION              | #303801 | REAR 1.1 MM |
|                     | #303802 | REAR 1.2 MM |
| STANDARD            | #303803 | REAR 1.3 MM |
|                     | #303804 | REAR 1.4 MM |
|                     | #303805 | REAR 1.5 MM |
|                     | #303806 | REAR 1.6 MM |

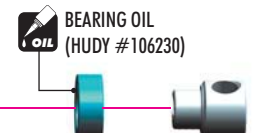

930407  
BB 4x7x2.5



# 5. FRONT & REAR TRANSMISSION

## ! FRONT ANTI-ROLL BAR

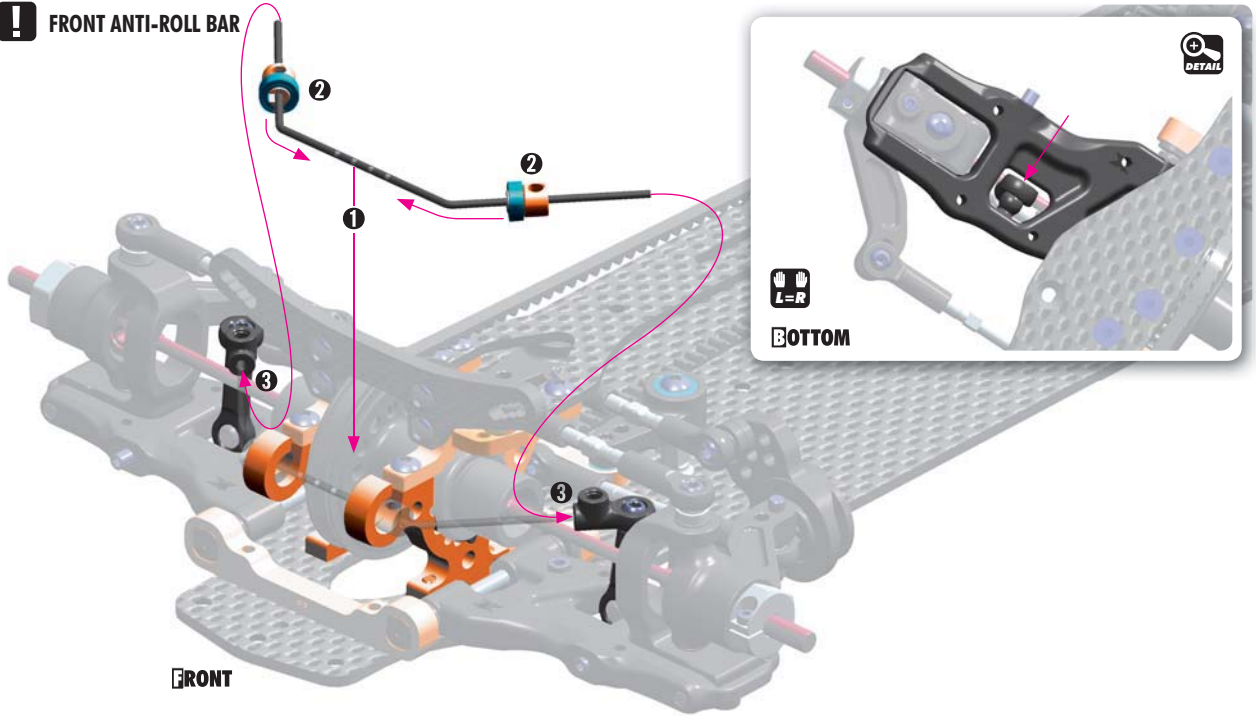

## ! FRONT ANTI-ROLL BAR

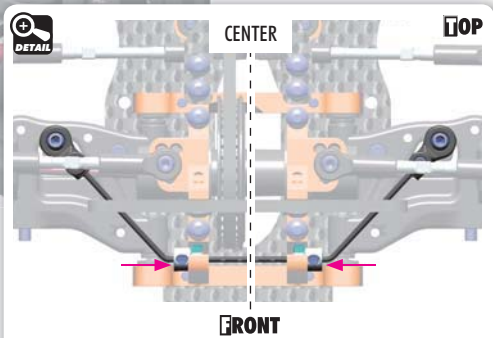
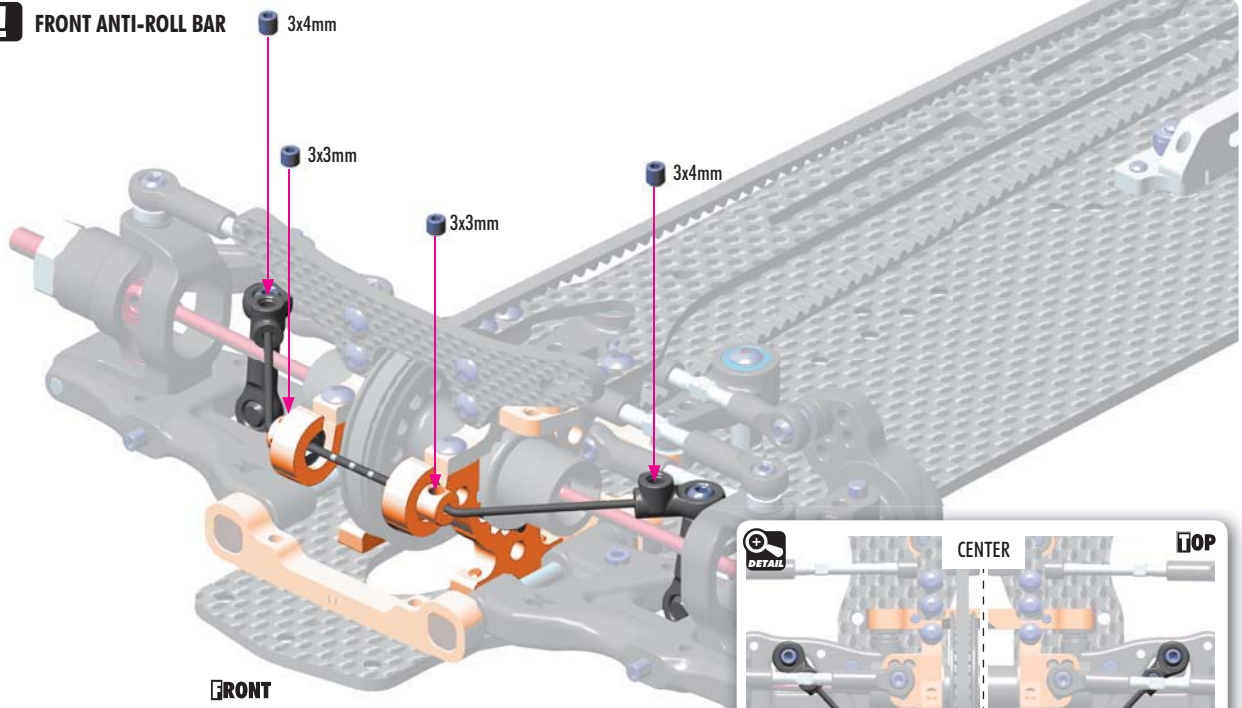

Set the bar into the center, remove the play in the bushings, and tighten the setscrews fully.

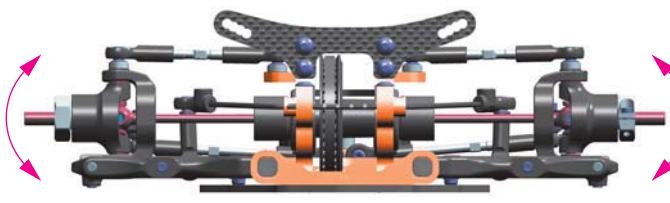

When the bars are set, verify that both sides move at the same time. If they do, the bars are set up correctly. If not, make sure that both downstops are the same and that the bar wire is flat.



If the sides still does not move at the same time, adjust the length of the bar holders.

# 5. FRONT & REAR TRANSMISSION

## REAR ANTI-ROLL BAR

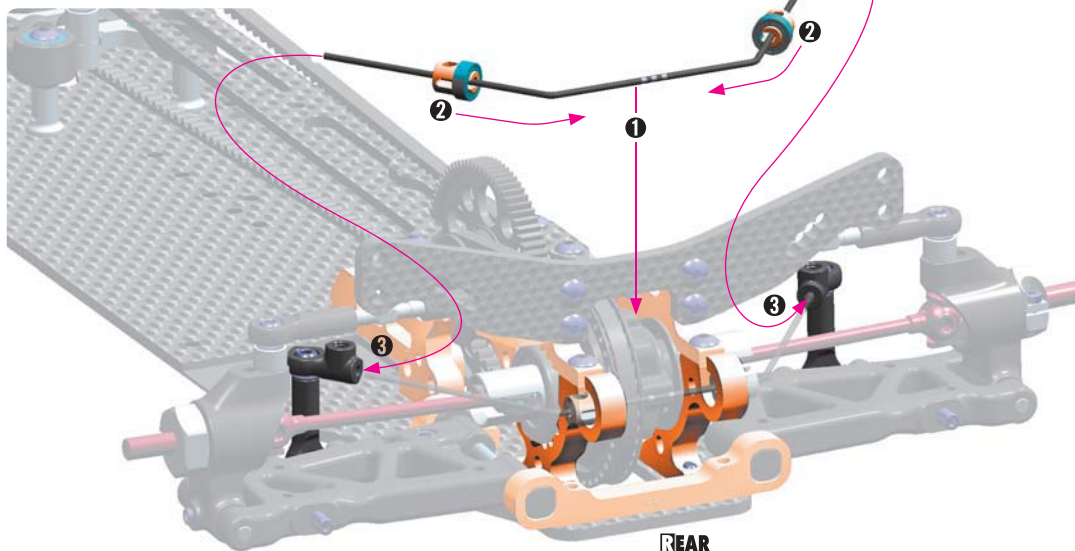

**2x** INITIAL POSITION

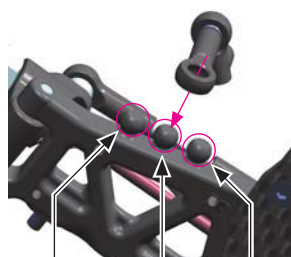

OUTER MIDDLE INNER

### STANDARD SUSPENSION

INITIAL POSITION = MIDDLE BALL

Use the **INNER** ball on low-traction tracks (mainly low-traction carpet tracks). The car will have more traction & more steering, but will be more difficult to drive because the car will roll more.

Use the **MIDDLE** ball on low- to medium-traction tracks (asphalt, carpet). The car will have a little less rear traction and the car will roll a little less which will make it easier to drive with more cornering speed.

Use the **OUTER** ball on high-traction tracks (mainly high-traction asphalt tracks). The car will roll even less which will allow the use of more throttle in the corners, however the car will have less traction.

### ACTIVE REAR SUSPENSION™

ARS arm has only two holes which are identical as inner and middle ball on the standard rear arm.



ANTI-ROLL BARS

901303  
SB M3x3

901304  
SB M3x4

## REAR ANTI-ROLL BAR

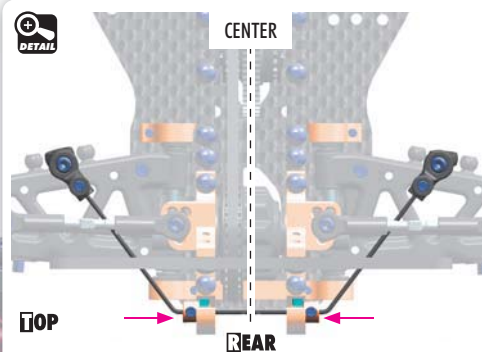
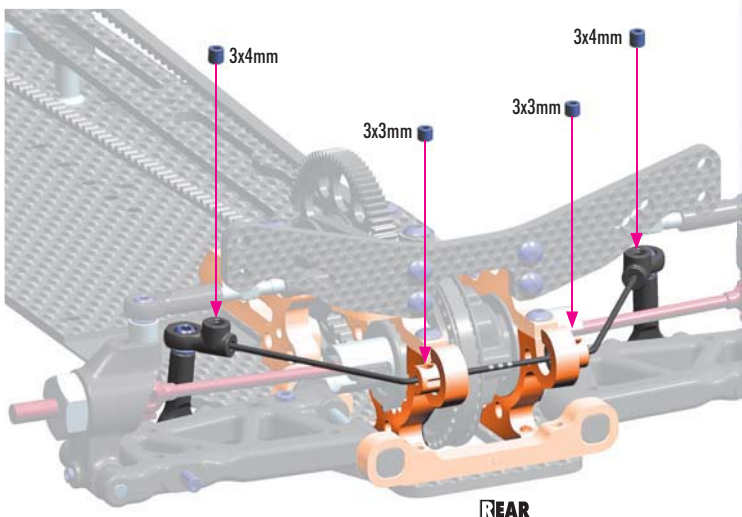

Set the bar into the center, remove the play in the bushings, and tighten the setscrews fully.



When the bars are set, verify that both sides move at the same time. If they do, the bars are set up correctly. If not, make sure that both downstops are the same and that the bar wire is flat.



If the sides still does not move at the same time, adjust the length of the bar holders.

# 6. SHOCK ABSORBERS

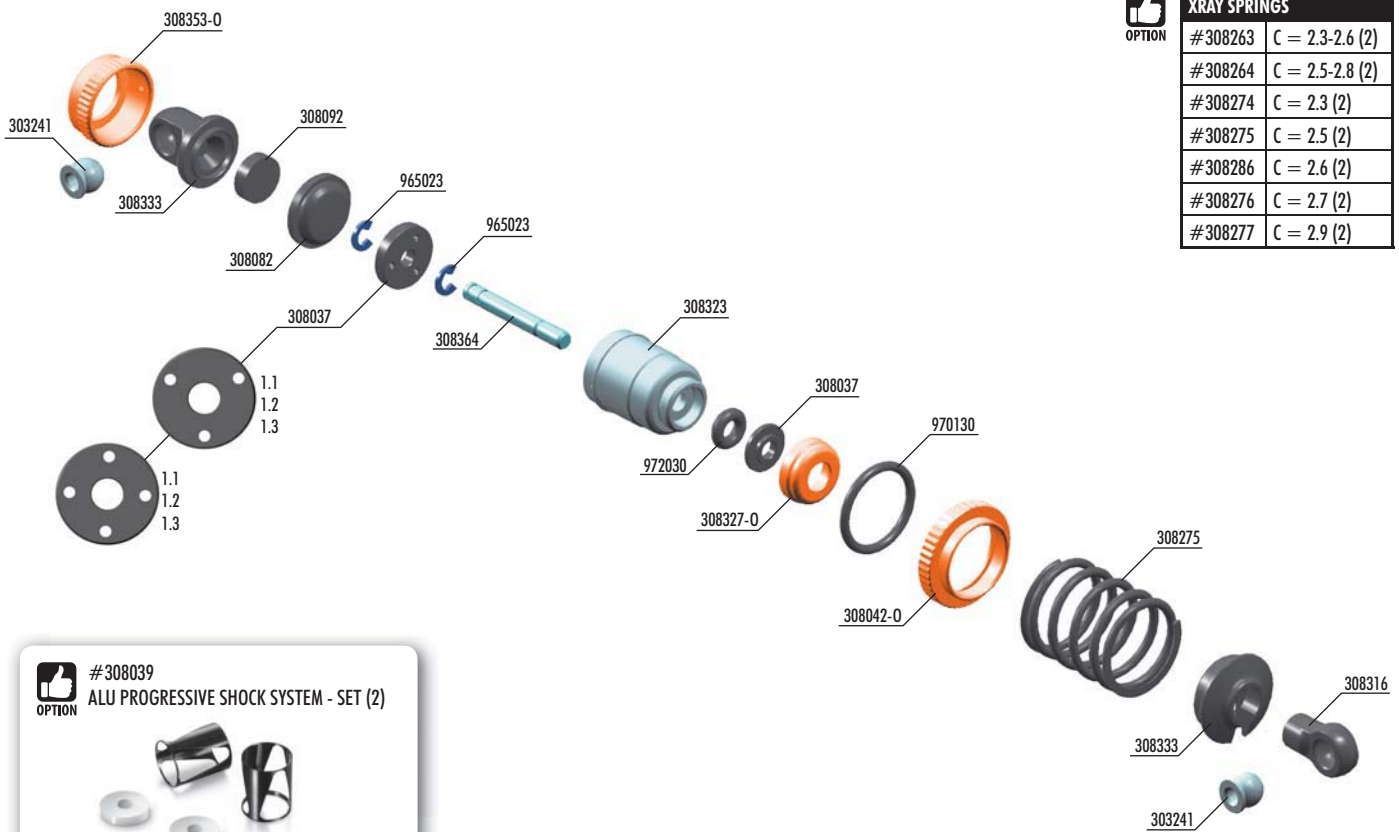

| XRAY SPRINGS |                 |
|--------------|-----------------|
| #308263      | C = 2.3-2.6 (2) |
| #308264      | C = 2.5-2.8 (2) |
| #308274      | C = 2.3 (2)     |
| #308275      | C = 2.5 (2)     |
| #308286      | C = 2.6 (2)     |
| #308276      | C = 2.7 (2)     |
| #308277      | C = 2.9 (2)     |



#308039  
ALU PROGRESSIVE SHOCK SYSTEM - SET (2)



Progressive shock system for touring cars for improved traction and steering characteristics. Shock insert has 3 triangle cuts and is used with piston without holes. The hardness of the shock is influenced not by the holes in the piston but with the insert.



- |           |  |           |  |
|-----------|--|-----------|--|
| 30 3241   | BALL UNIVERSAL 5.8 MM HEX (4)                        | 30 8333   | T4 COMPOSITE SHOCK PARTS FOR ALU SHOCKS          |
| 30 8037   | COMPOSITE PISTONS 4-HOLE 1.0-1.2MM, 3-HOLE 1.0-1.2MM | 30 8353-0 | T4 ALU SHOCK CAP-NUT WITH VENT HOLE - ORANGE (2) |
| 30 8042-0 | T4 ALU SHOCK ADJUSTABLE NUT - ORANGE (2)             | 30 8364   | T4 HARDENED SHOCK SHAFT FOR ALU SHOCKS (2)       |
| 30 8082   | T4 SHOCK ABSORBER MEMBRANE (4)                       | 30 8275   | XRAY SPRING-SET C=2.5                            |
| 30 8092   | T4 SHOCK FOAM INSERTS (4)                            | 96 5023   | E-CLIP 2.3 (10)                                  |
| 30 8307-0 | XRAY T4 ALU SHOCK ABSORBER-SET - ORANGE (2)          | 97 0130   | O-RING 13 x 1.5 (10)                             |
| 30 8316   | SHOCK BALL JOINT - OPEN (4)                          | 97 2030   | SILICONE O-RING 3 x 2 (10)                       |
| 30 8323   | T4 ALU XRAY SHOCK BODY (2)                           |           |  |
| 30 8327-0 | ALU CAP FOR XRAY SHOCK BODY - ORANGE                 |           |  |



965023  
C 2.3

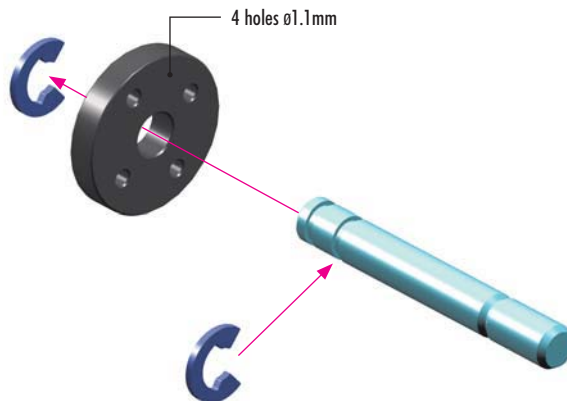



# 6. SHOCK ABSORBERS



**4x**

SHOCK OIL

SHOCK OIL

NOTE ORIENTATION



**4x**

SHOCK OIL

SHOCK OIL

CUTAWAY VIEW

Be careful not to cross-thread the collar on the shock body.

**4x**

1mm

INCORRECT

CORRECT

**HINT:** Pre-thread the ball joint using an M3 screw.  
**WARNING!** Be careful not to pre-thread too far, since the ball joint may split or the plastic threads may strip out.

**4x**

SHOCK OIL

SHOCK FILLING

- 1 Fully extend the piston rod so the piston is at the bottom of the shock body.
- 2 Hold the shock upright and slightly overfill the shock body with shock oil.
- 3 Let the oil settle and allow air bubbles to rise to the top. Slowly move the piston up and down to allow oil into all cavities within the shock body.
- 4 Extend the piston rod most of the way out of the shock body. Let the shock rest for 5 minutes to allow the air bubbles to escape.
- 5 Add shock oil as necessary.

**4x**

FOAM INSERT

CUTAWAY VIEW

After you insert the membrane, ensure that it is fully seated inside the alu cap.

**4x**

When installing the shock cap assembly on the shock body, some oil will leak out... this is normal.

Tighten the cap and clean off any excess oil.

After the shock is assembled, the shock rod will push itself out of the shock body fairly quickly.

Follow the next procedure to adjust the rebound.

**OPTION**

| SHOCK OILS |        | SHOCK OILS |         |
|------------|--------|------------|---------|
| #106310    | 100cSt | #106355    | 550cSt  |
| #106315    | 150cSt | #106360    | 600cSt  |
| #106320    | 200cSt | #106365    | 650cSt  |
| #106325    | 250cSt | #106370    | 700cSt  |
| #106330    | 300cSt | #106375    | 750cSt  |
| #106335    | 350cSt | #106380    | 800cSt  |
| #106340    | 400cSt | #106390    | 900cSt  |
| #106345    | 450cSt | #106410    | 1000cSt |
| #106350    | 500cSt | #106420    | 2000cSt |



# 6. SHOCK ABSORBERS

## REBOUND ADJUSTMENT

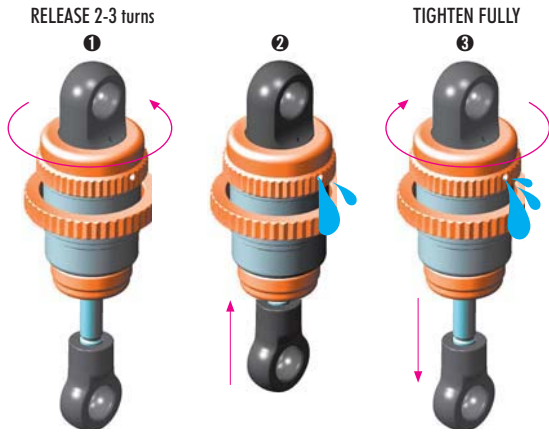

AFTER THE SHOCK IS ASSEMBLED YOU HAVE TO SET THE SHOCK REBOUND:

- 1 Release the shock cap by 2-3 turns.
- 2 Push the shock shaft fully up. For the first time the extra oil will release through the hole in the alu cap-nut.
- 3 Tighten the shock cap. When tightening the shock cap, extra oil will again release through the hole in the alu cap - nut. When tightening, the shock shaft will push out from the shock body.

## REBOUND CHECK

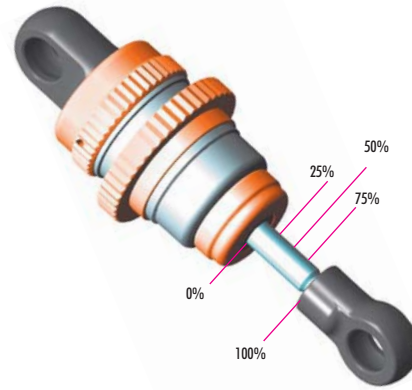

REBOUND CHECK:

It is very important to push the shock shaft into the shock body slowly otherwise air can come into the shock body which would create bubbles.

- 100% rebound - do not do step 2 and 3
- 75% rebound - repeat step 2 and 3 until the shock shaft will push out 75% of its length
- 50% rebound - repeat step 2 and 3 until the shock shaft will push out 50% of its length
- 25% rebound - repeat step 2 and 3 until the shock shaft will push out 25% of its length
- 0% rebound - repeat step 2 and 3 until the shock shaft will push out 0% of its length

If the shock shaft does not rebound enough, you will have to refill the shock with shock oil, and then repeat the bleeding and rebound adjustment procedure.

4x

## SHOCK LENGTH ADJUSTMENT:

It is VERY important that all shocks are equal length. Fully extend the shock absorber and measure the end-to-end length; we recommend using digital calipers to give an accurate measurement. If a shock absorber is shorter or longer than others, adjust the shock length by tightening or loosening the ball joint on the shock rod.

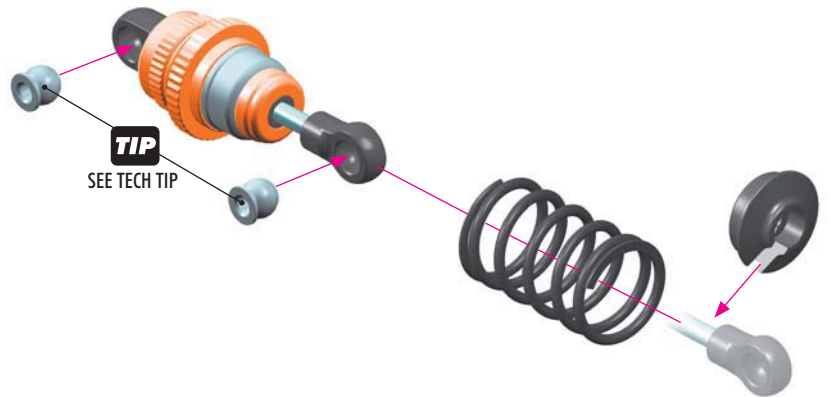

TIP

SEE TECH TIP

SET-UP BOOK

SHOCK DAMPING  
SPRING RATE SELECTION

## TECH TIP

Follow this tech tip to properly install pivot balls into the top pivot and bottom ball joint.

- Parts Needed:
- M3x16 SH screw
  - M3 shim

Note that the composite parts have two sides, noticeable around the pivot ball hole: one side has a shiny finish, the other side has a regular finish.

SHINY FINISH SIDE

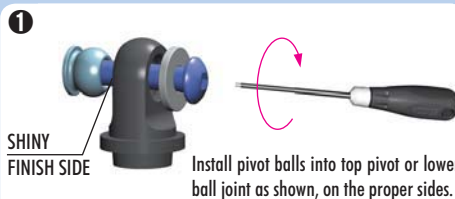

Note that the lower pivot ball has an extra shoulder.

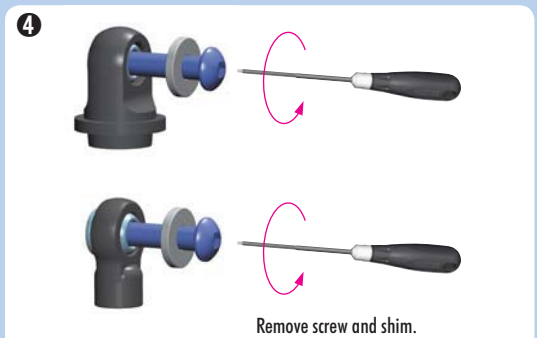
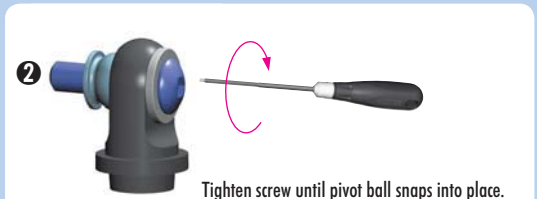
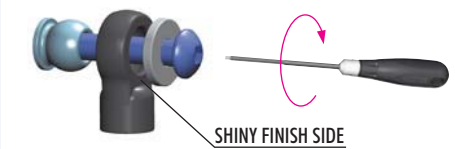

# 7. FRONT & REAR ASSEMBLY

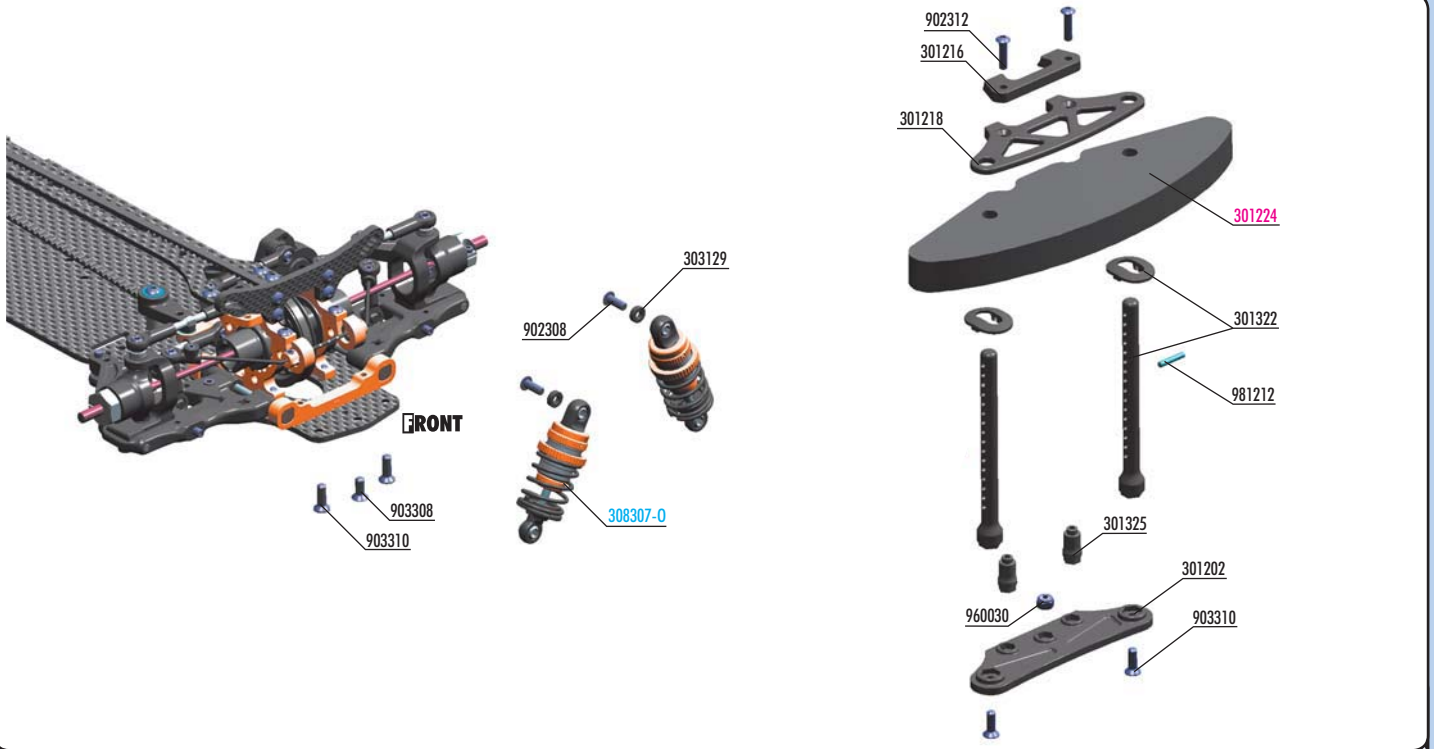

**BAG**

**07**

- 30 1202 COMPOSITE BUMPER
- 30 1213 GRAPHITE BUMPER UPPER HOLDER 2.5MM (OPTION)
- 30 1216 COMPOSITE BUMPER UPPER HOLDER BRACE
- 30 1218 COMPOSITE UPPER HOLDER FOR BUMPER
- 30 1322 FRONT BODY MOUNT SET
- 30 1323 FRONT BODY MOUNT SET +1MM HEIGHT (OPTION)
- 30 1324 FRONT BODY MOUNT SET +2MM HEIGHT (OPTION)
- 30 1325 T4 COMPOSITE BRACE FOR BUMPER - LOW (2)
- 30 3129 COMPOSITE SET OF WHEELBASE SHIMS (3x1MM; 1x2MM) (2)

- 90 2308 HEX SCREW SH M3x8 (10)
- 90 2312 HEX SCREW SH M3x12 (10)
- 90 3308 HEX SCREW SFH M3x8 (10)
- 90 3310 HEX SCREW SFH M3x10 (10)
- 96 0030 NUT M3 (10)
- 98 1212 PIN 2x12 (10)

30 1224 T4 FOAM BUMPER

30 8307-0 XRAY T4 ALU SHOCK ABSORBER-SET - ORANGE (2)

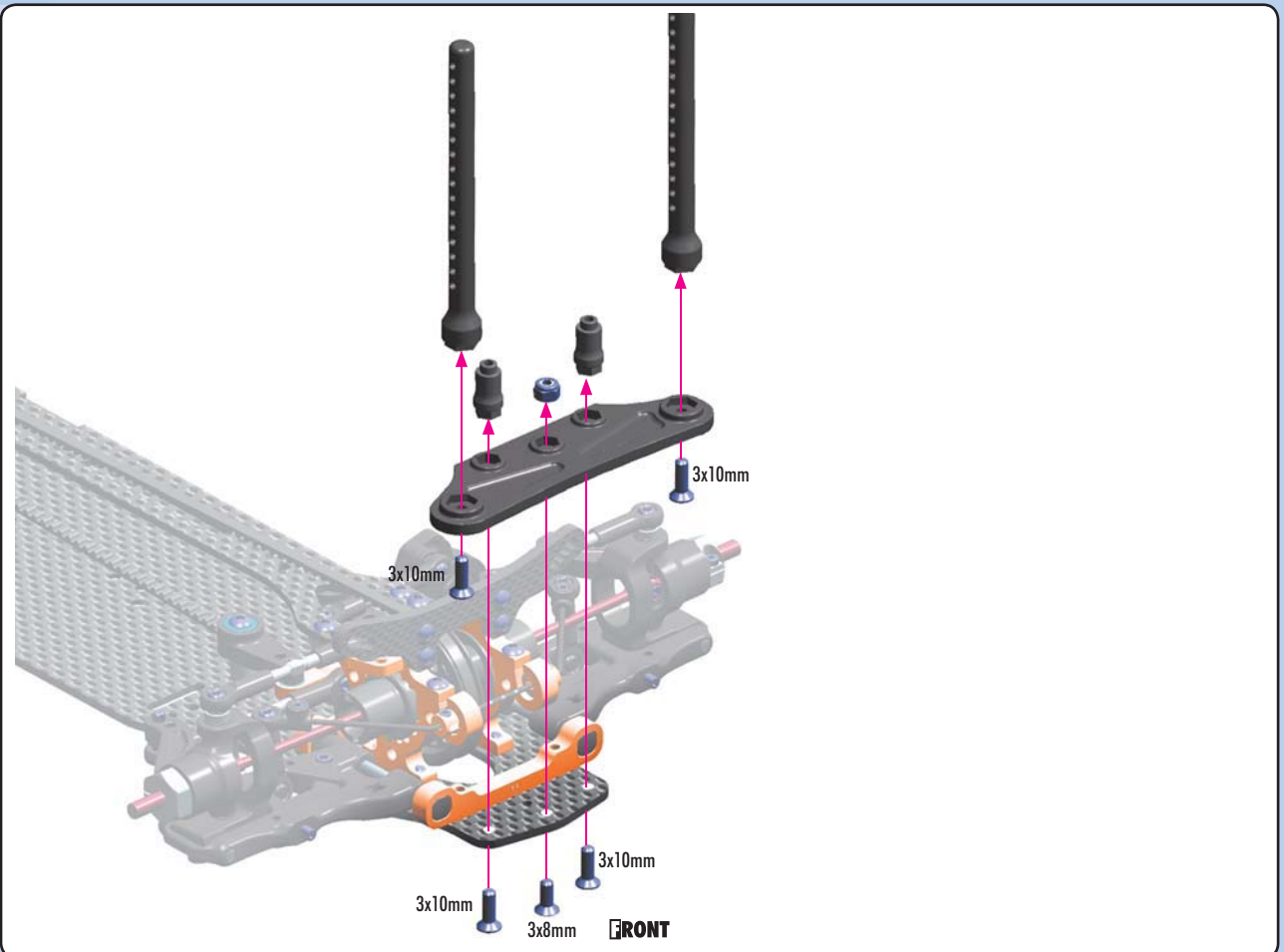



# 7. FRONT & REAR ASSEMBLY



902312  
SH M3x12

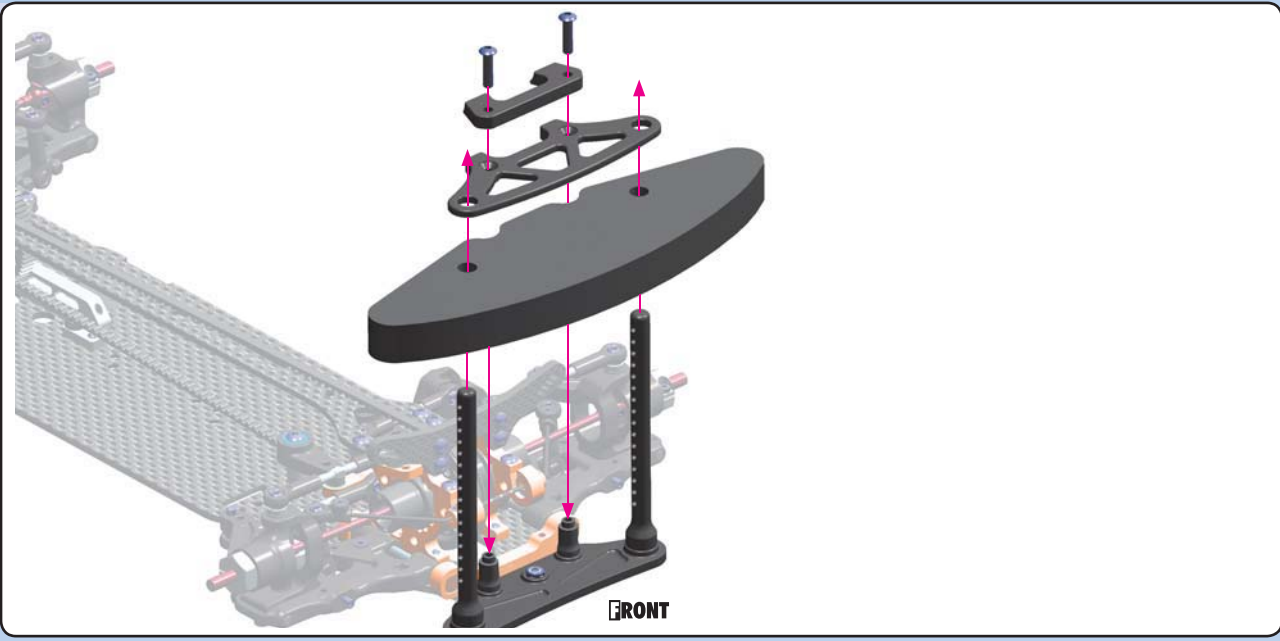

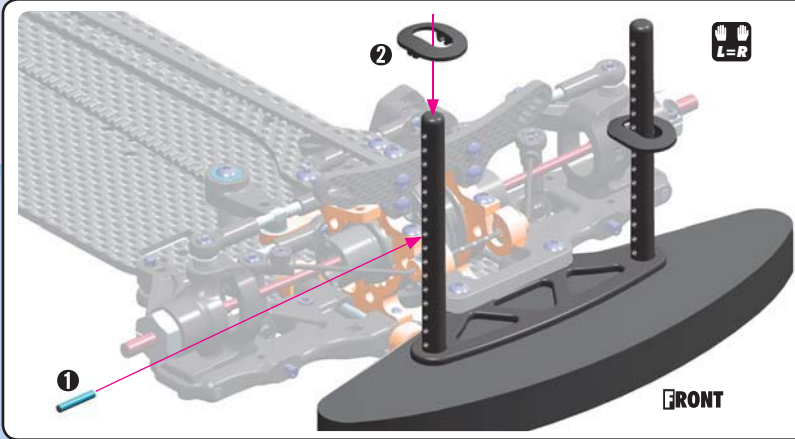

981212  
P 2x12



**#301351-0**  
ALU ADJUSTABLE BODY POST STOP (2)  
OPTION



Very handy, easily externally adjustable body post from Swiss 7075 T6 aluminum. Allows for adjustment of body height by 3mm without needing to change the position on the body post.



902308  
SH M3x8

**IO**  
303129  
SHIM 3x6x2

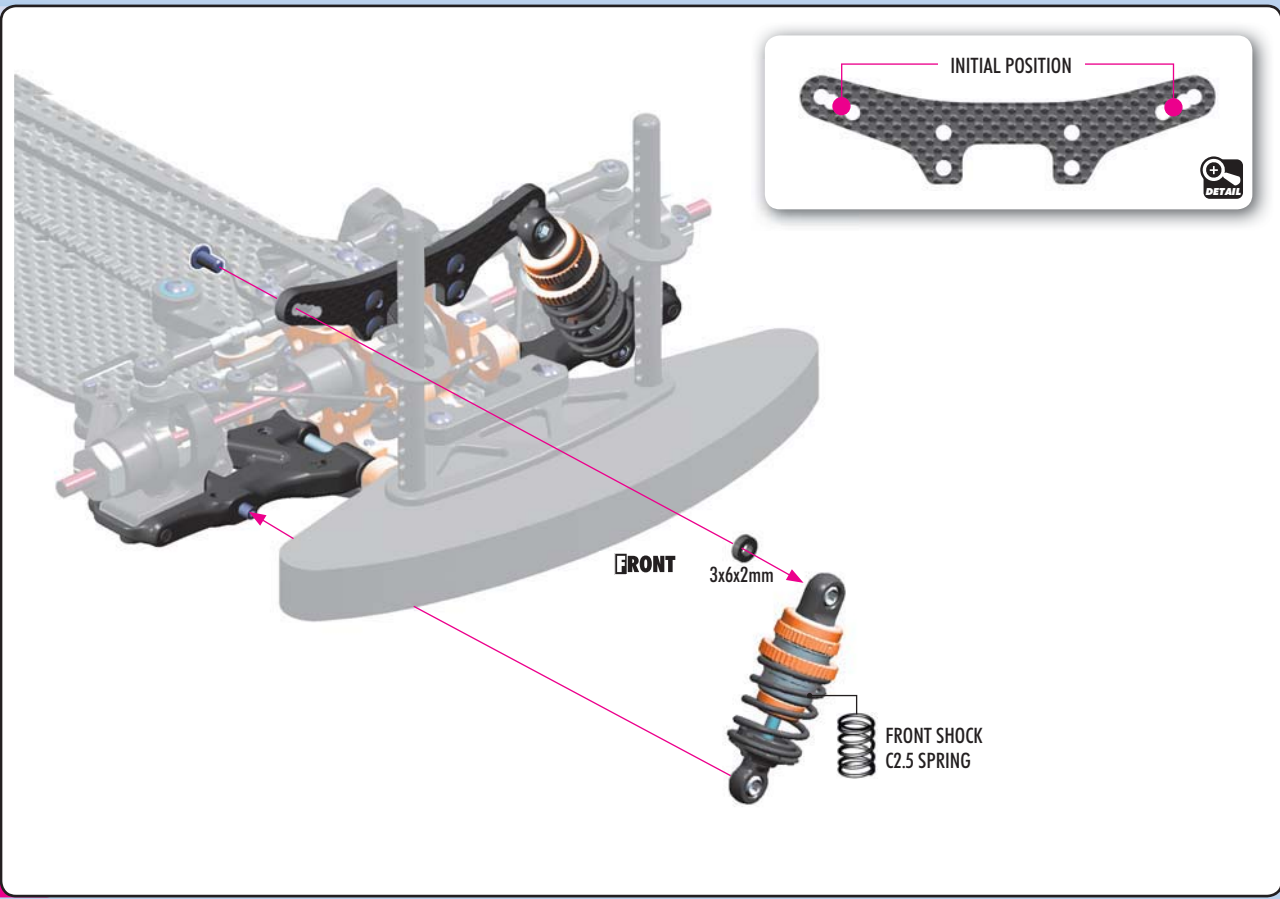

SET-UP BOOK

SHOCK POSITION  
RIDE HEIGHT  
DROOP

# 7. FRONT & REAR ASSEMBLY

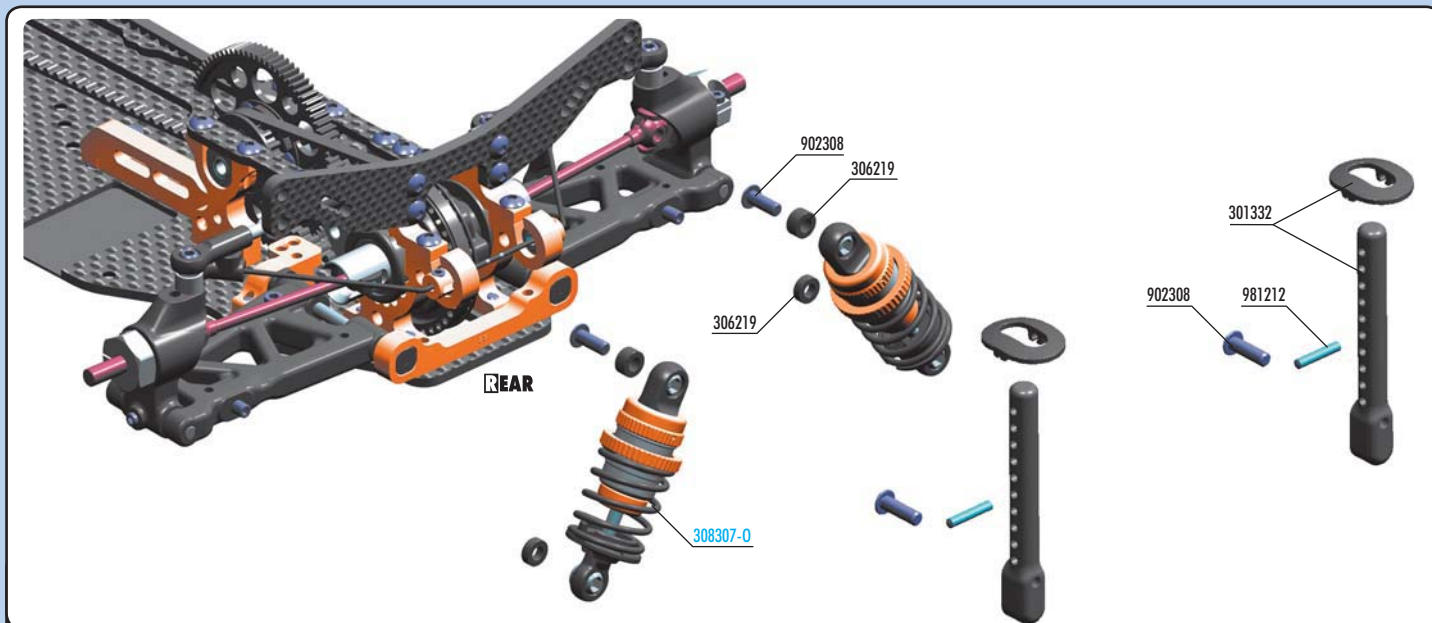

**BAG**

**07**

30 1332 REAR BODY MOUNT SET  
 30 1333 REAR BODY MOUNT SET +1MM HEIGHT (OPTION)  
 30 1334 REAR BODY MOUNT SET +2MM HEIGHT (OPTION)  
 30 6219 COMPOSITE SET OF SERVO SHIMS (4)

90 2308 HEX SCREW SH M3x8 (10)  
 98 1212 PIN 2x12 (10)  
 30 8307-0 XRAY T4 ALU SHOCK ABSORBER-SET - ORANGE (2)

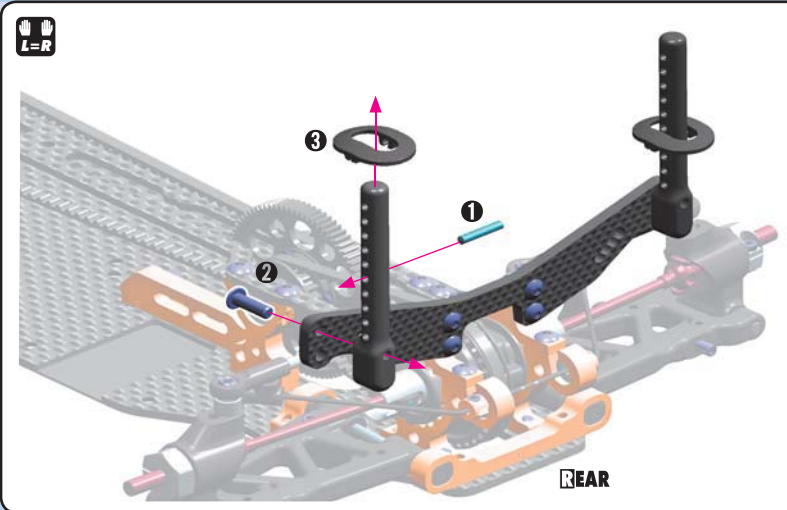

**#301351-0**  
 ALU ADJUSTABLE BODY POST STOP (2)  
 OPTION

Very handy, easily externally adjustable body post from Swiss 7075 T6 aluminum. Allows for adjustment of body height by 3mm without needing to change the position on the body post.

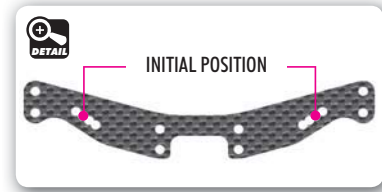
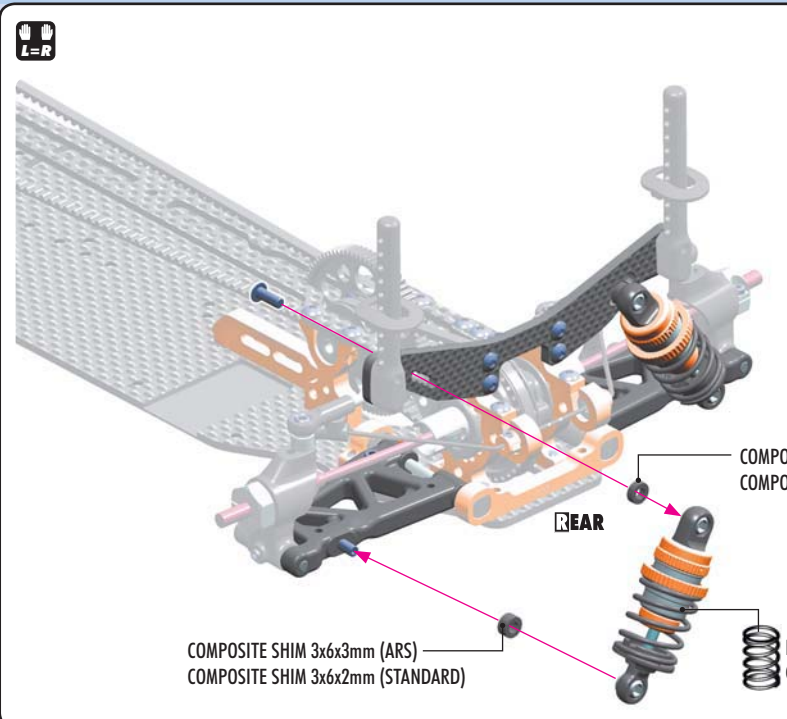

COMPOSITE SHIM 3x6x3mm (ARS)  
 COMPOSITE SHIM 3x6x2mm (STANDARD)  
 COMPOSITE SHIM 3x6x2mm (ARS)  
 COMPOSITE SHIM 3x6x3mm (STANDARD)  
 REAR SHOCK  
 C2.5 SPRING

**SET-UP BOOK**

SHOCK POSITION  
 RIDE HEIGHT  
 DROOP

# 7. FINAL ASSEMBLY

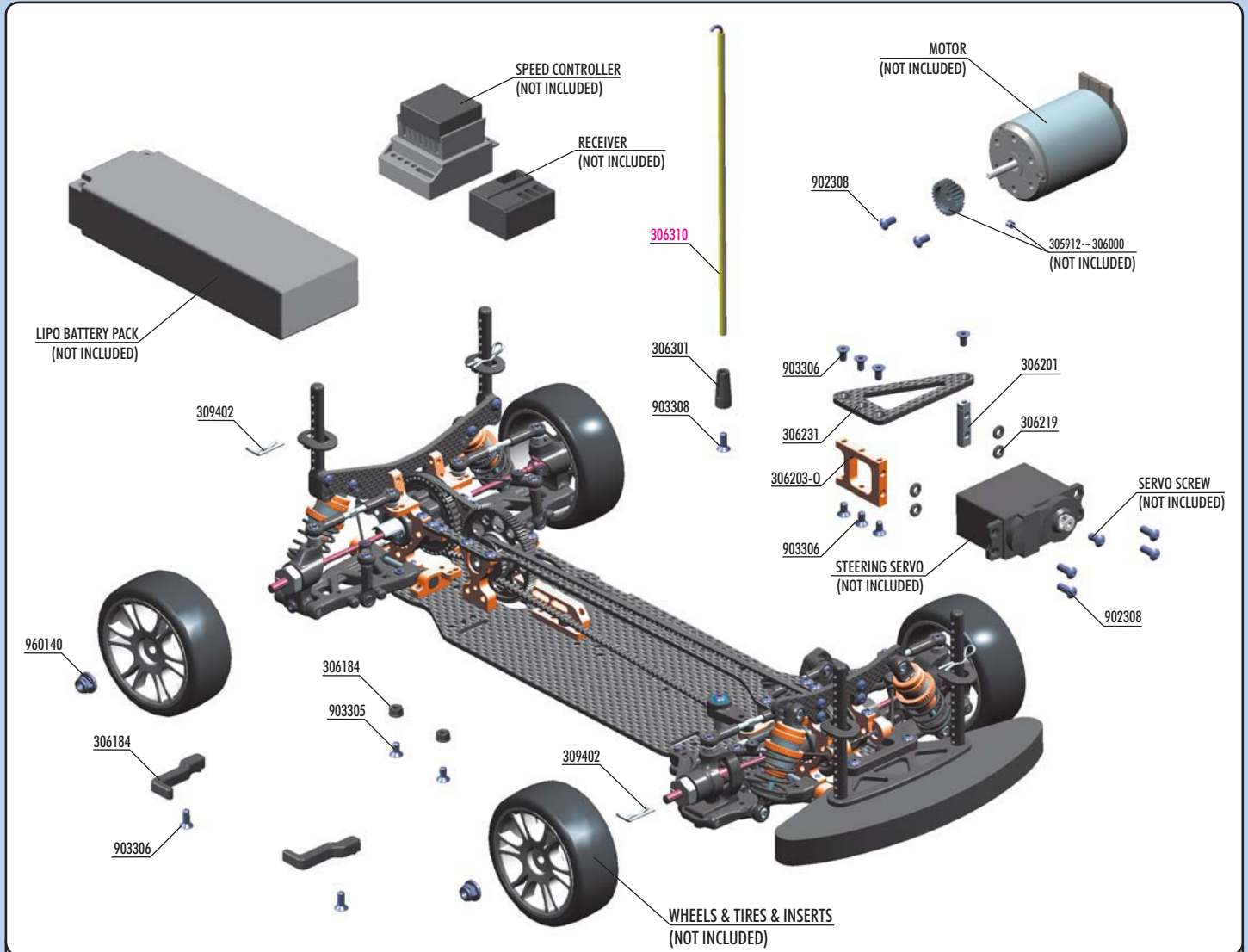

**BAG**

**07**

- 30 3061 LiPo CHASSIS GRAPHITE MOTOR GUARD (OPTION)
- 305912-306000 NARROW PINION GEAR ALU HARD COATED (OPTION)
- 30 6163-K GRAPHITE BATTERY STRAP 6-CELL (SET) - BLACK (OPTION)
- 30 6184 LONG COMPOSITE LIPO BATTERY BACKSTOP (1 + 1)
- 30 6186 ALU LIPO BATTERY BACKSTOP (F + R) (OPTION)
- 30 6188 T4 GRAPHITE ADJUSTABLE BATTERY HOLDER (OPTION)
- 30 6191 T4 GRAPHITE + ALU FULLY ADJUSTABLE BATTERY HOLDER (OPTION)
- 30 6201 ALU SERVO MOUNT - LONG
- 30 6203-0 T4'15 ALU SERVO MOUNT - ORANGE
- 30 6219 COMPOSITE SET OF SERVO SHIMS (4)

- 30 6301 ANTENNA MOUNT - THIN
- 30 6231 T4'15 GRAPHITE SERVO HOLDER 2.5MM
- 30 9402 BODY CLIP FOR 6MM BODY POST (4)
- 90 2308 HEX SCREW SH M3x8 (10)
- 90 3305 HEX SCREW SFH M3x5 (10)
- 90 3306 HEX SCREW SFH M3x6 (10)
- 90 3308 HEX SCREW SFH M3x8 (10)
- 96 0140 NUT M4 WITH FLANGE (10)

30 6310 ANTENNA (2)

**IO**

306219 SHIM 3x6x1

**IO**

306219 SHIM 3x6x2

**IO**

306219 SHIM 3x6x3

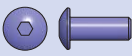

902308 SH M3x8



903306 SFH M3x6

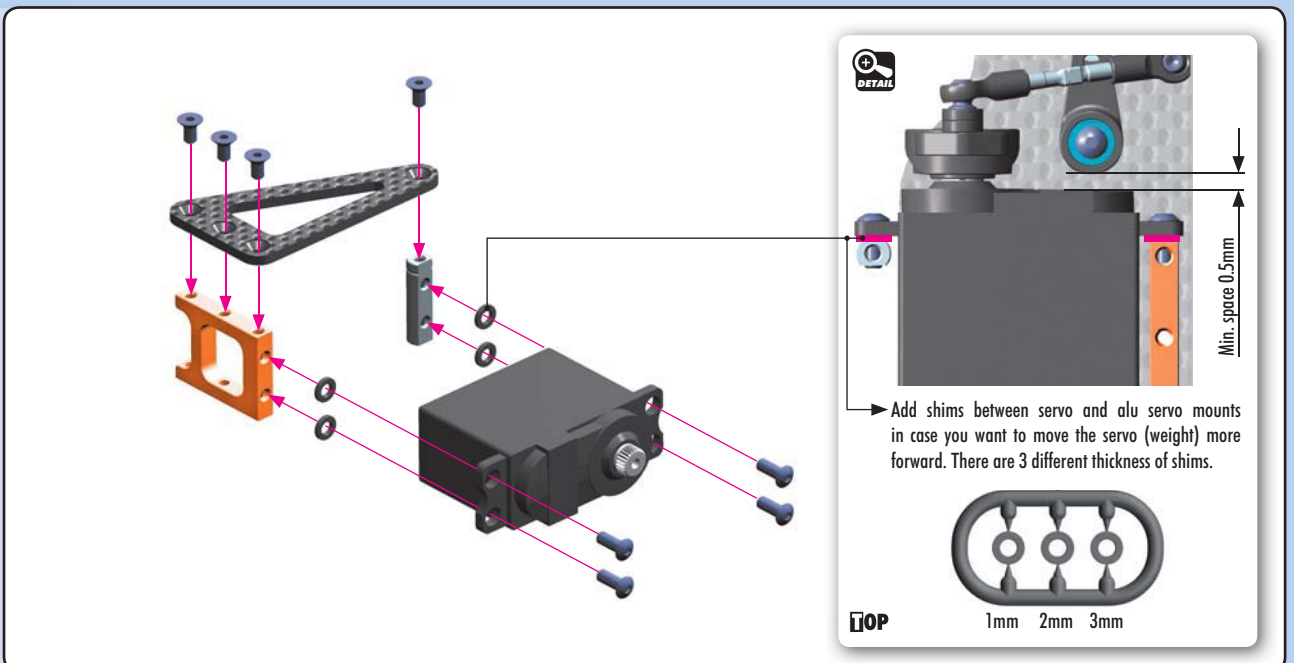



# 7. FINAL ASSEMBLY



903306  
SFH M3x6

For improved weight balance and for more space for electronics, we recommend using a narrow, light servo.

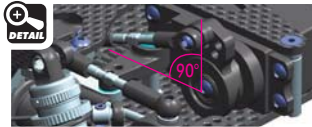

Attach servo arm to servo output shaft using screw from servo. Servo saver must be perpendicular to chassis when servo is in neutral.



**IMPORTANT!**

When adjusting steering on the radio, we recommend using full steering adjustment in order to get the best steering from the car. It is important to verify that the steering block does not touch the C-hub; that would lead to chassis tweak due to extra servo strain.

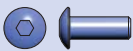
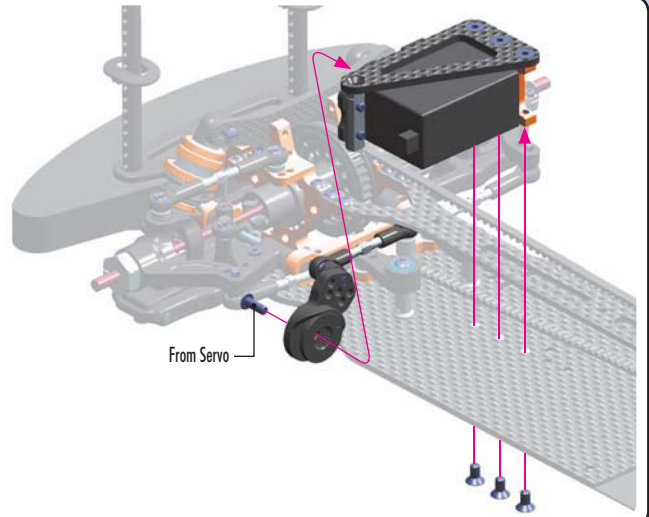

902308  
SH M3x8



Adjust the motor so the pinion meshes with the spur gear properly. Make sure the gear mesh is not too tight.

There should be a small amount of play between the teeth of the pinion gear and the spur gear.

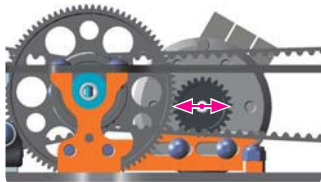

3x2.5mm set screw (#901302)  
(NOT INCLUDED)

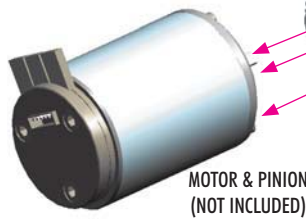

MOTOR & PINION  
(NOT INCLUDED)

**TIP**

Some motors do not have a chamfer on the motor housing. If your motor does not have a chamfer on the housing and you want to use a small pinion, the motor may touch the top deck. Use a moto-tool with grinding bit or file to remove material from the top-deck; this will allow the motor to be moved closer to the spur gear.

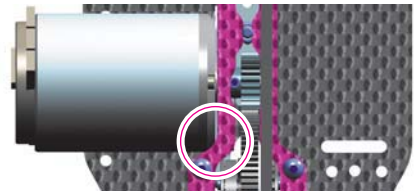

#303061  
LiPo Chassis Graphite Motor Guard



**SET-UP BOOK**

GEARING ADJUSTMENT



903308  
SFH M3x8

Feed the receiver wire into the antenna tube

RECEIVER  
(NOT INCLUDED)



**NOTE:** In case the antenna tube does not hold the antenna properly, apply a small drop of the CA glue to the outside end of the antenna tube while inserting it into the holder. Make sure not to apply glue to the inside of the antenna tube, or the antenna wire may get permanently stuck.



SPEED CONTROLLER  
(NOT INCLUDED)

DOUBLE-SIDED TAPE  
(NOT INCLUDED)

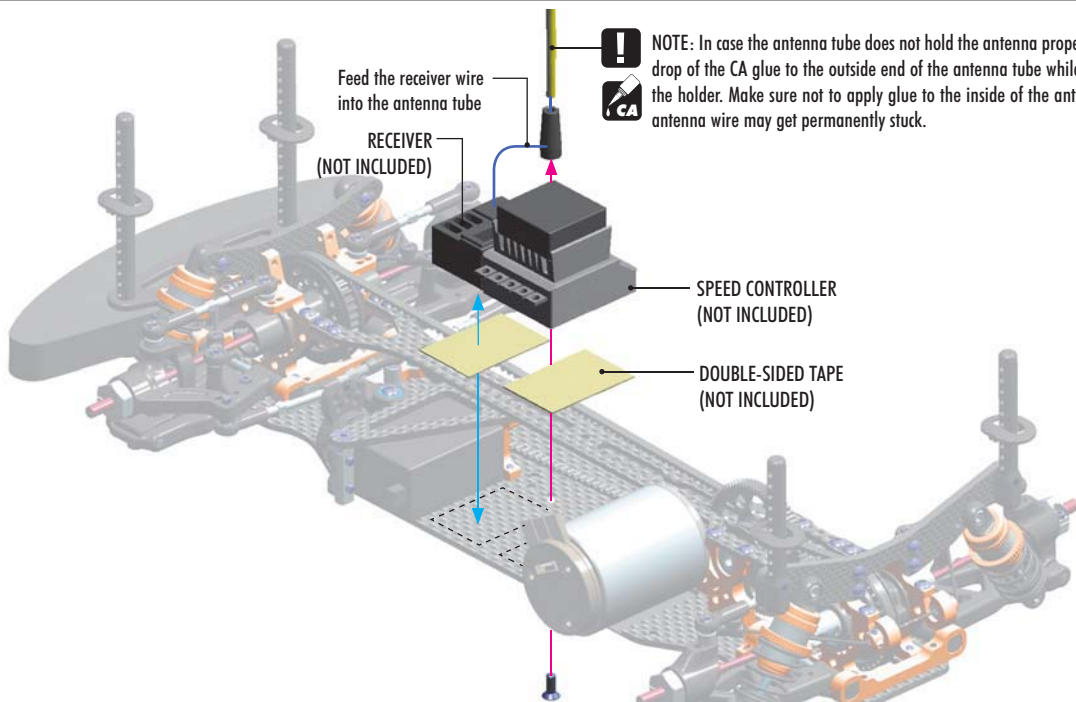

# 7. FINAL ASSEMBLY



903305  
SFH M3x5



903306  
SFH M3x6

**REAR**

3x6mm

3x5mm

3x5mm

3x6mm

**TIP** Using the optional stand and shims with screw allows adjustment of battery position, which has a direct influence on balance.

**OPTION** #306186  
ALU LIPO BATTERY BACKSTOPS (F+R)

**OPTION** #306191  
T4 GRAPHITE + ALU FULLY ADJUSTABLE BATTERY HOLDER

**4x**

WHEELS & TIRES & INSERTS (NOT INCLUDED)

**! WARNING!** Follow the adhesive manufacturer's instructions for proper use and safety. Wear proper eye and hand protection.

CA



960140  
N M4

LIPO BATTERY PACK (NOT INCLUDED)

Make sure the wheel nuts are very tight, so the wheels do not loosen during racing.

We recommend using #107870 HUDY Fibre Reinforced Tape (NOT INCLUDED)

**OPTION** #306165  
GRAPHITE BATTERY STRAP

Is designed for LiPo batteries and ensures quick & easy mounting of the battery pack into the car. Depending on the LiPo battery height, additional shims may have to be mounted below the stands.

# SET-UP SHEET

# XRAY T4'16

|                |  |  |  |
|----------------|--|--|--|
| RACE           |  |  |  |
| TRACK          |  |  |  |
| NAME           |  |  |  |
| CITY / COUNTRY |  |  |  |
| CONTACT        |  |  |  |
| DATE           |  |  |  |

|                 |  |                   |  |
|-----------------|--|-------------------|--|
| TEMPERATURE AIR |  | TEMPERATURE TRACK |  |
|-----------------|--|-------------------|--|

|               |                |              |             |
|---------------|----------------|--------------|-------------|
| QUAL POSITION | FINAL POSITION | BEST LAPTIME | RACE LENGTH |
|               |                | /sec         | /min        |

| TRACK         |  |
|---------------|--|
| TRACK SURFACE | <input type="checkbox"/> CARPET <input type="checkbox"/> ASPHALT |

|              |   |
|--------------|---|
| TRACK LAYOUT | <input type="checkbox"/> TECHNICAL <input type="checkbox"/> MIXED <input type="checkbox"/> FAST |
|--------------|---|

|          |  |
|----------|--|
| TRACTION | <input type="checkbox"/> LOW <input type="checkbox"/> MEDIUM <input type="checkbox"/> HIGH |
|----------|--|

| FRONT   | TRANSMISSION                                   | REAR |
|---|--|------|
| SOLID AXLE <input type="checkbox"/> YES                 | BALL DIFFERENTIAL <input type="checkbox"/> YES |      |
| SOLID ONE WAY DIFFERENTIAL <input type="checkbox"/> YES |  |      |
| ONE WAY DIFFERENTIAL <input type="checkbox"/> YES       |  |      |

|  |  |
|--|--|
| GEAR DIFFERENTIAL <input type="checkbox"/> YES | GEAR DIFFERENTIAL <input type="checkbox"/> YES |
| OIL /Cst                                       | OIL /Cst                                       |

|            |               |                   |
|------------|---------------|-------------------|
| PINION / T | SPUR GEAR / T | FINAL DRIVE RATIO |
|            |               |                   |

| FRONT | SHOCKS       | REAR |
|-------|--------------|------|
|       | SHOCK TYPE   |      |
|       | XRAY SPRINGS |      |
|       | OIL /Cst     |      |
|       | REBOUND %    |      |

|  |                 |  |
|--|-----------------|--|
| <input type="checkbox"/> YES <input type="checkbox"/> NO | FOAM INSERTS    | <input type="checkbox"/> YES <input type="checkbox"/> NO |
| <input type="checkbox"/> YES <input type="checkbox"/> NO | O-RING ON SHAFT | <input type="checkbox"/> YES <input type="checkbox"/> NO |

|                                  |                                    |                                  |
|----------------------------------|------------------------------------|----------------------------------|
| <input type="checkbox"/> 3 HOLES | PISTONS<br>1.0mm<br>1.1mm<br>1.2mm | <input type="checkbox"/> 3 HOLES |
| <input type="checkbox"/> 4 HOLES |                                    | <input type="checkbox"/> 4 HOLES |
|                                  |                                    | OTHERS                           |

|              |               |              |
|--------------|---------------|--------------|
| THICKNESS/mm | ANTI-ROLL BAR | THICKNESS/mm |
|--------------|---------------|--------------|

|  |                 |
|--|-----------------|
|  | TIRES           |
|  | INSERTS         |
|  | ADDITIVE        |
|  | ADDITIVE TIMING |

|              |             |           |            |
|--------------|-------------|-----------|------------|
| FRONT LEFT   | FRONT RIGHT | REAR LEFT | REAR RIGHT |
|              |             |           |            |
| TREATED AREA |             |           |            |

| ECCENTRIC BUSHINGS | ROLL CENTER | ECCENTRIC BUSHINGS |
|--------------------|-------------|--------------------|
| FF                 | 1 0.5 1 0.5 | RR                 |
| FR                 | 1 0.5 1 0.5 | RF                 |

|       |        |
|-------|--------|
| MOTOR | TIMING |
|-------|--------|

|     |           |
|-----|-----------|
| ESC | BATTERIES |
|-----|-----------|

|      |      |
|------|------|
| BODY | WING |
|------|------|

COMMENTS

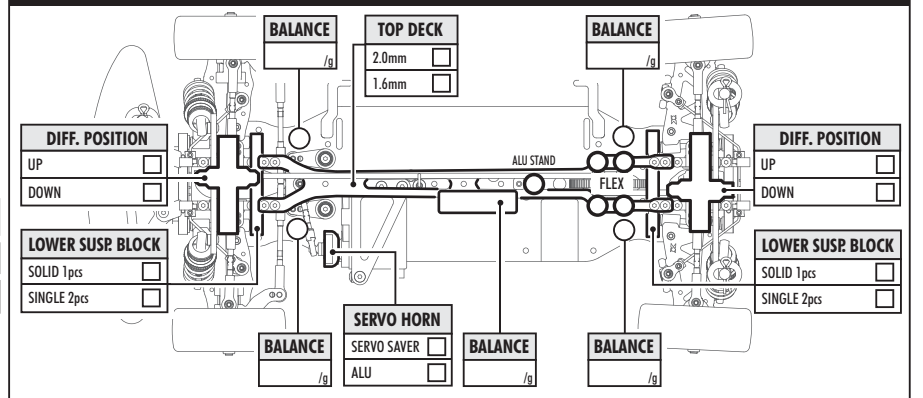
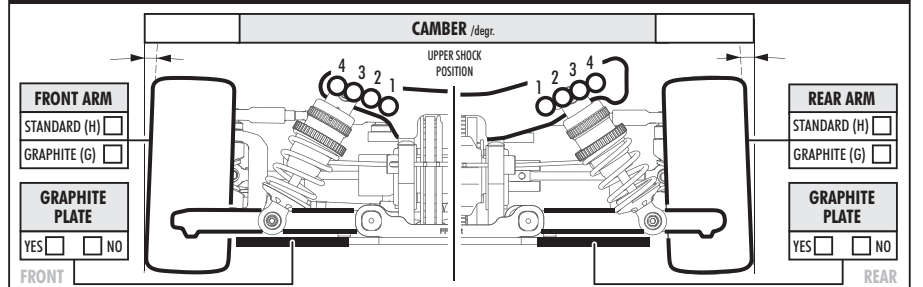
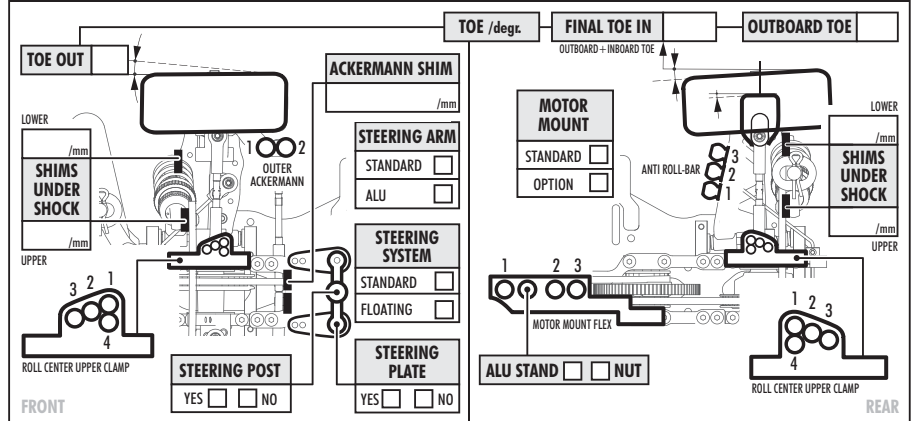
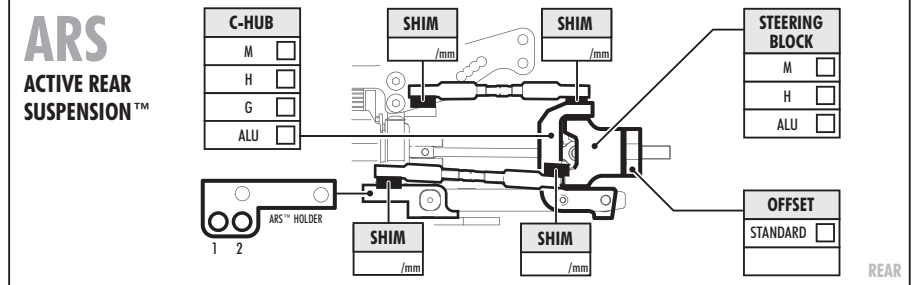
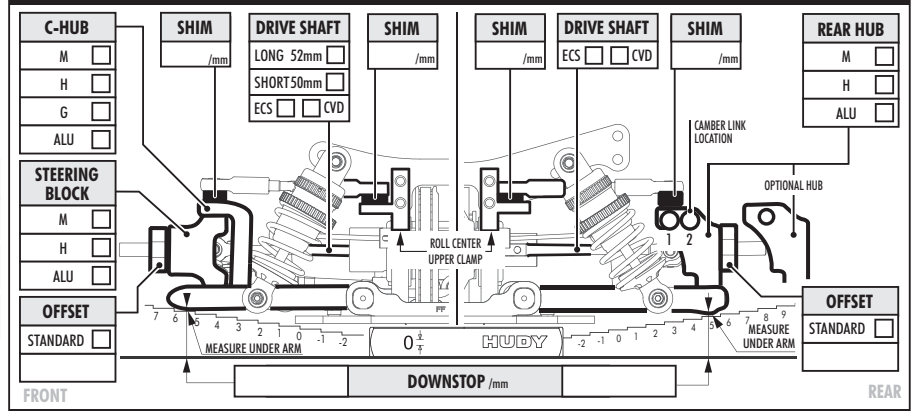
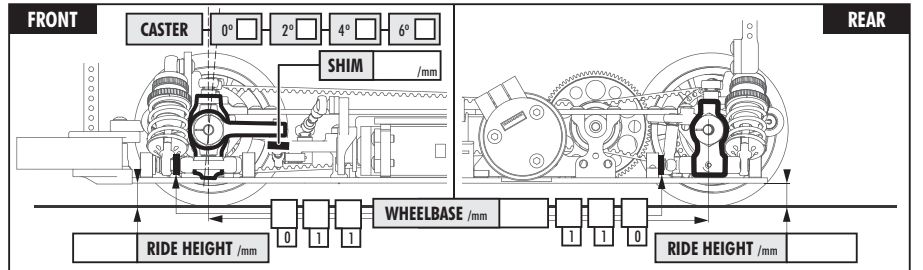



**[www.teamxray.com](http://www.teamxray.com)**

**XRAY EUROPE**

XRAY, K VÝSTAVISKU 6992, 91101 TRENCIN, SLOVAKIA, EUROPE  
PHONE: +421-32-740 11 00, FAX: +421-32-740 11 09, [info@teamxray.com](mailto:info@teamxray.com)

**XRAY USA**

RC AMERICA, 2030 Century Center Blvd #15, Irving, TX 75062, USA  
PHONE: 214-744-2400, FAX: 214-744-2401, [xray@rcamerica.com](mailto:xray@rcamerica.com)