

SET-UP SHEET

XRAY T4

| | | | |
|----------------|--------------|---------|--|
| RACE | DHI-CUP 2013 | | |
| TRACK | DHI-CUP | | |
| NAME | steven olsen | | |
| CITY / COUNTRY | odense | Denmark | |
| CONTACT | | | |

| | | | | |
|------|------------|------------------------|-----|-------|
| DATE | 14/01/2013 | TEMPERATURE / °F or °C | AIR | TRACK |
|------|------------|------------------------|-----|-------|

| | | | |
|---------------------|-------------------|----------------|----------------------|
| QUALIFYING POSITION | BEST LAPTIME /sec | FINAL POSITION | RACE LENGTH /minutes |
| 24 | 13.85 | 21 | 5 |

| | | | |
|-----------------|--|--|-------------------------------|
| TRACK CONDITION | <input checked="" type="checkbox"/> CARPET | <input type="checkbox"/> ASPHALT | |
| | <input type="checkbox"/> TECHNICAL | <input checked="" type="checkbox"/> FAST | |
| TRACTION | <input type="checkbox"/> LOW | <input checked="" type="checkbox"/> MEDIUM | <input type="checkbox"/> HIGH |

| FRONT | REAR |
|--------------|------|
| TRANSMISSION | |

| | | | |
|----------------------|---|-------------------|---|
| SOLID AXLE | <input checked="" type="checkbox"/> YES | BALL DIFFERENTIAL | <input type="checkbox"/> YES |
| SOLID ONE WAY DIFF. | <input type="checkbox"/> YES | | |
| ONE WAY DIFFERENTIAL | <input type="checkbox"/> YES | | |
| GEAR DIFFERENTIAL | <input type="checkbox"/> YES | GEAR DIFFERENTIAL | <input checked="" type="checkbox"/> YES |
| OIL | | OIL | 2000 /cst |

| | | | |
|-------------------|-----------------|---------------|-----|
| PINION / T | 43 | SPUR GEAR / T | 100 |
| FINAL DRIVE RATIO | 2.3255813953488 | ROLLOUT | NaN |

| FRONT | REAR | |
|--------|--------------|--------|
| 2.5 | XRAY SPRINGS | 2.5 |
| 30 LRP | OIL / CST | 40 LRP |
| | LENGTH /mm | |
| | PRELOAD /mm | |
| | REBOUND % | |

| | | | | |
|------------------------------|--|-----------------|------------------------------|--|
| <input type="checkbox"/> YES | <input checked="" type="checkbox"/> NO | FOAM INSERTS | <input type="checkbox"/> YES | <input checked="" type="checkbox"/> NO |
| <input type="checkbox"/> YES | <input checked="" type="checkbox"/> NO | O-RING ON SHAFT | <input type="checkbox"/> YES | <input checked="" type="checkbox"/> NO |

| | | | | |
|----------------------------------|---|---------|----------------------------------|---|
| <input type="checkbox"/> 3 HOLES | <input checked="" type="checkbox"/> 4 HOLES | PISTONS | <input type="checkbox"/> 3 HOLES | <input checked="" type="checkbox"/> 4 HOLES |
| | | 1.0mm | | |
| | | 1.1mm | | |
| | | 1.2mm | | |
| | | OTHERS | | |

| | | | | |
|-----|--------------|---------------|--------------|-----|
| 1,4 | THICKNESS/mm | ANTI-ROLL BAR | THICKNESS/mm | 1,2 |
|-----|--------------|---------------|--------------|-----|

| | | |
|-----------------|-----------------|--------------------|
| CPX | TIRES | CPX |
| MG | INSERTS | MG |
| 20 min wipe off | ADDITIVE | MG |
| | ADDITIVE TIMING | 10 min before race |



| WHEELS | |
|----------------------------|--|
| S <input type="checkbox"/> | M <input type="checkbox"/> H <input type="checkbox"/> |
| HARDNESS | S <input type="checkbox"/> M <input type="checkbox"/> H <input type="checkbox"/> |

| | | | |
|-------|--------------|-----------|-----------------|
| MOTOR | LRP 13.5 | TIMING | 30* fixed |
| ROTOR | stock | ARMATURE | stock |
| ESC | Nosram COMET | BATTERIES | Nosram 6700 |
| BODY | montech 3.0 | WING | stock 3mm lower |

● - APPLIED S-SOFT M-MEDIUM H-HARD

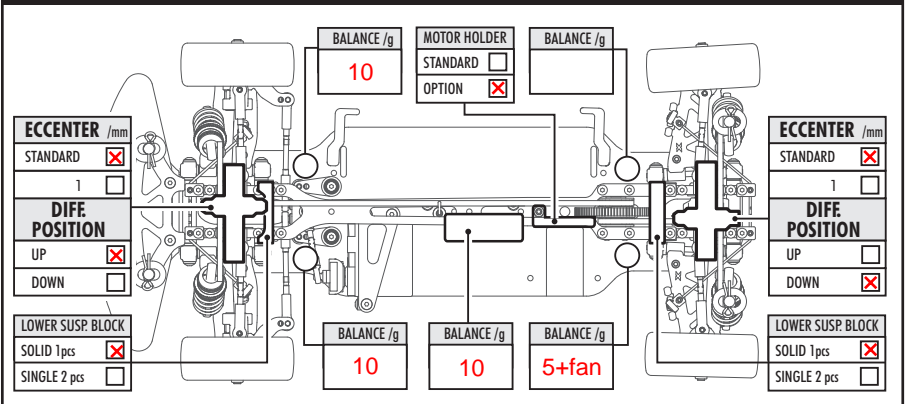
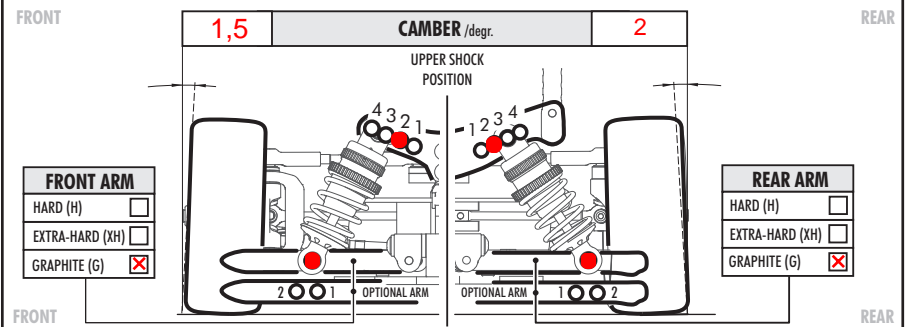
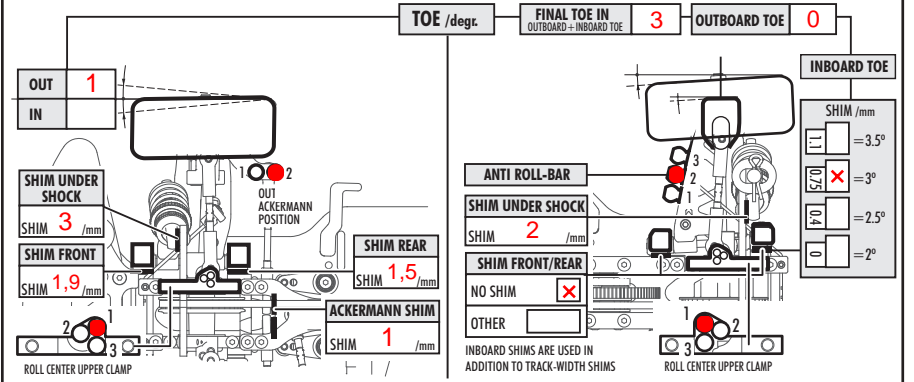
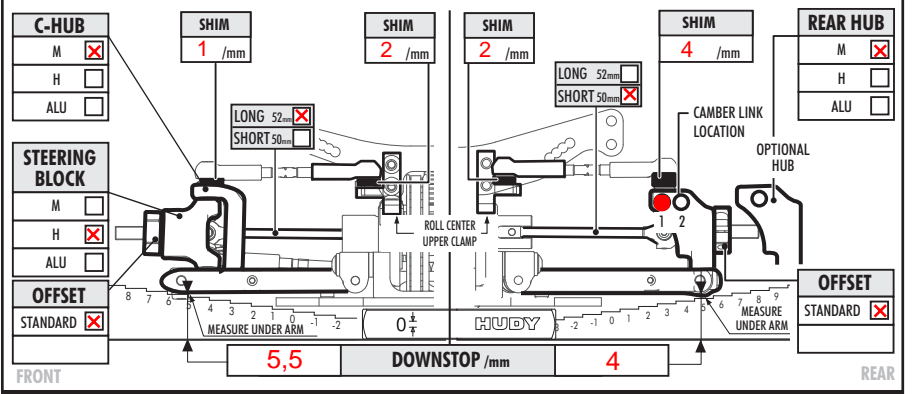
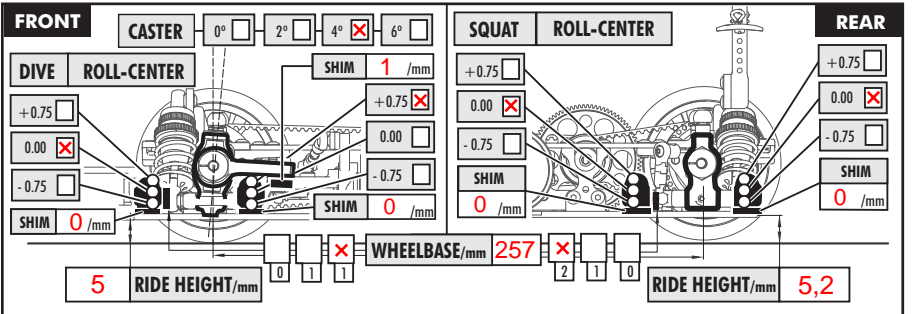

COMMENTS
 ECS in front
 front rollbar tightend 1mm
 only 8 screws in topdeck (all screws in bulkhead)
 grued front tirewall