

SET-UP SHEET

XRAY T4

RACE	ETS Round 2		
TRACK	Czech Republic		
NAME	Marco Kaufmann		
CITY / COUNTRY	Hrotovice	Czech Republic	
CONTACT	facebook.com/pages/Marco-Kaufmann		

DATE	23/01/2013	TEMPERATURE / °F or °C	AIR	TRACK			
QUALIFYING POSITION	8	BEST LAP TIME /sec	12,0	FINAL POSITION	9	RACE LENGTH /minutes	5

TRACK CONDITION	<input type="checkbox"/> TECHNICAL	<input checked="" type="checkbox"/> CARPET	<input type="checkbox"/> ASPHALT
TRACTION	<input type="checkbox"/> LOW	<input type="checkbox"/> MEDIUM	<input checked="" type="checkbox"/> HIGH

FRONT		REAR	
TRANSMISSION			
SOLID AXLE	<input checked="" type="checkbox"/> YES	BALL DIFFERENTIAL	<input type="checkbox"/> YES
SOLID ONE WAY DIFF.	<input type="checkbox"/> YES		
ONE WAY DIFFERENTIAL	<input type="checkbox"/> YES		
GEAR DIFFERENTIAL	<input type="checkbox"/> YES	GEAR DIFFERENTIAL	<input checked="" type="checkbox"/> YES
OIL		OIL	2000 /cst
PINION / T	18	SPUR GEAR / T	116
FINAL DRIVE RATIO	6.444444444444444	ROLLOUT	0

FRONT		REAR	
2,5	XRAY SPRINGS	2,5	
350	OIL / CST	400	
	LENGTH /mm		
0	PRELOAD /mm		
	REBOUND %	0	

<input type="checkbox"/> YES <input type="checkbox"/> NO	FOAM INSERTS	<input type="checkbox"/> YES <input type="checkbox"/> NO
<input type="checkbox"/> YES <input type="checkbox"/> NO	O-RING ON SHAFT	<input type="checkbox"/> YES <input type="checkbox"/> NO
<input type="checkbox"/> 3 HOLES <input checked="" type="checkbox"/> 4 HOLES	PISTONS	<input type="checkbox"/> 3 HOLES <input checked="" type="checkbox"/> 4 HOLES
	1.0mm	
	1.1mm	
	1.2mm	
	OTHERS	
1,4	THICKNESS/mm ANTI-ROLL BAR	1,2

TIRES	
AME	ADDITIVE
10min	ADDITIVE TIMING
AME	15min

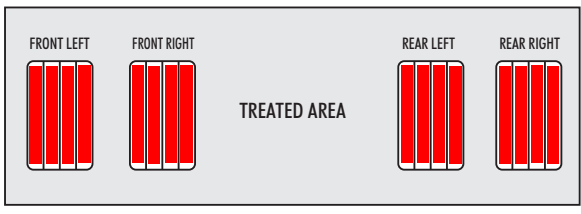

Ride 32	WHEELS	Ride 32
S <input type="checkbox"/> M <input type="checkbox"/> H <input type="checkbox"/>	HARDNESS	S <input type="checkbox"/> M <input type="checkbox"/> H <input type="checkbox"/>

MOTOR	Orca 4,5T	TIMING	
ROTOR	Orca	ARMATURE	
ESC		BATTERIES	Orca
BODY	Mazda6	WING	MR33

● - APPLIED S-SOFT M-MEDIUM H-HARD

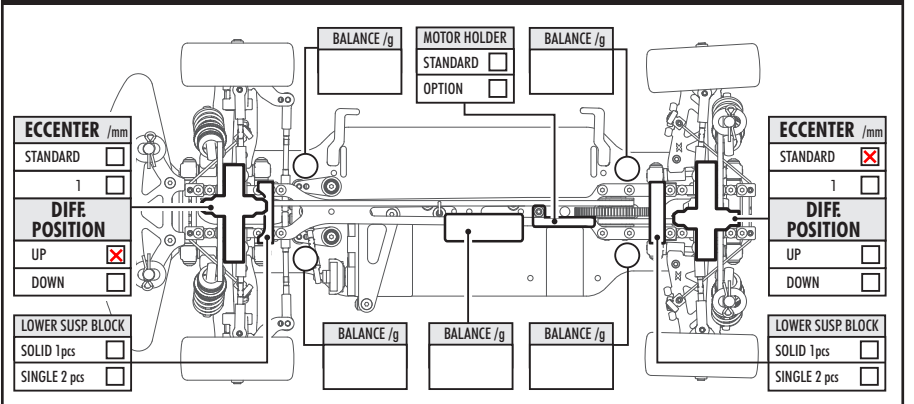
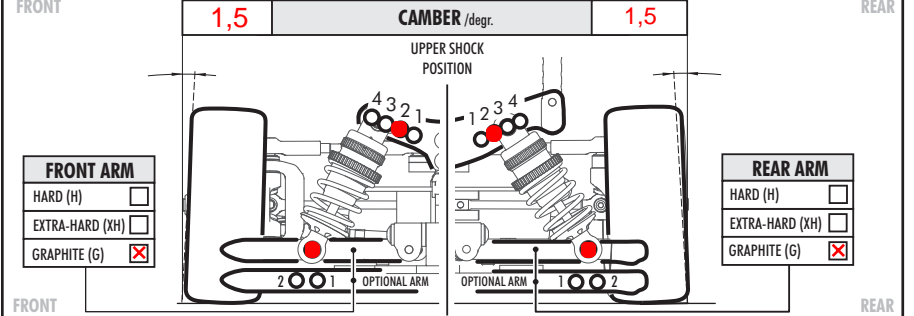
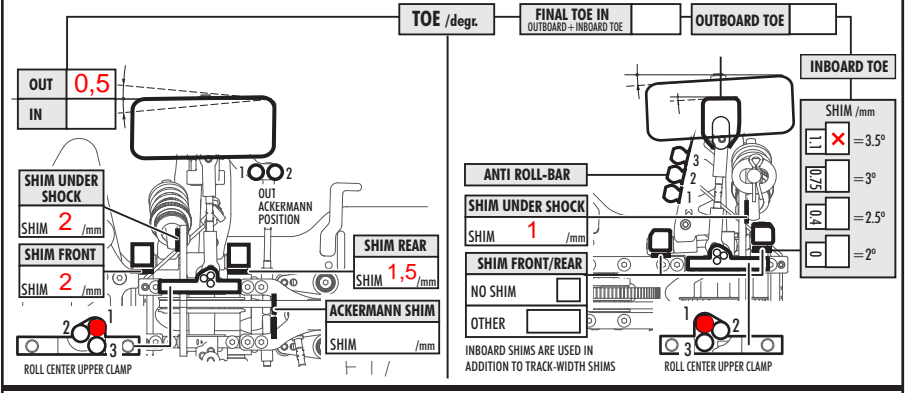
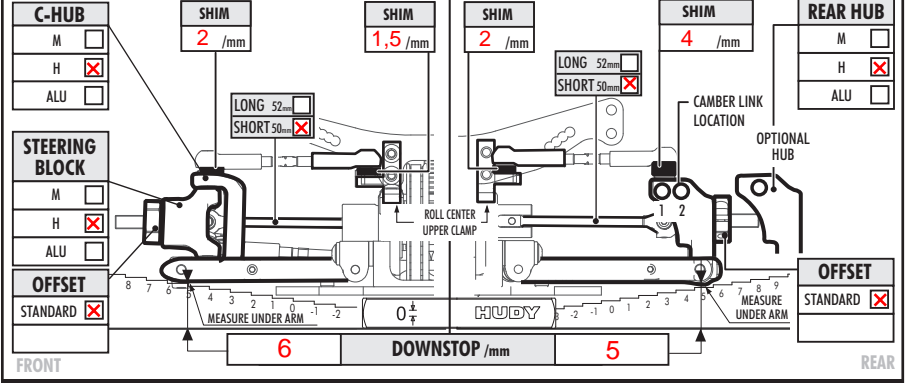
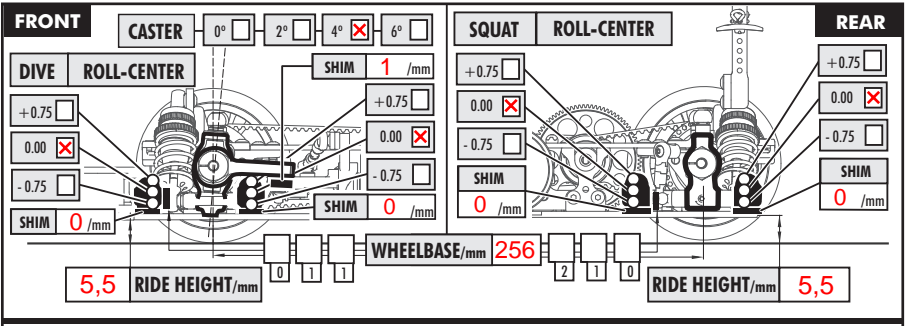

COMMENTS

Glue on the Sites from the dront Tires.