

# SET-UP SHEET

RACE	<b>ETS 5 Austira</b>		
TRACK	<b>Traiskirchen</b>		
NAME	<b>Magnus Vassmar</b>		
CITY / COUNTRY	<b>Eskilstuna</b>	<b>Sweden</b>	
CONTACT			

DATE	<b>17/06/2013</b>	TEMPERATURE / °F or °C	AIR	<b>25</b>	TRACK
------	-------------------	------------------------	-----	-----------	-------

QUALIFYING POSITION	<b>10</b>	BEST LAPTIME /sec	<b>14.8</b>	FINAL POSITION	<b>9</b>	RACE LENGTH /minutes	<b>5</b>
---------------------	-----------	-------------------	-------------	----------------	----------	----------------------	----------

<b>TRACK CONDITION</b>		<input type="checkbox"/> CARPET	<input checked="" type="checkbox"/> ASPHALT
<input checked="" type="checkbox"/> TECHNICAL	<input type="checkbox"/> MIXED	<input type="checkbox"/> FAST	
<b>TRACTION</b>		<input type="checkbox"/> LOW	<input checked="" type="checkbox"/> HIGH

FRONT		REAR	
<b>TRANSMISSION</b>			

SOLID AXLE	<input type="checkbox"/> YES	BALL DIFFERENTIAL	<input type="checkbox"/> YES
SOLID ONE WAY DIFF.	<input type="checkbox"/> YES		
ONE WAY DIFFERENTIAL	<input type="checkbox"/> YES		

GEAR DIFFERENTIAL	<input type="checkbox"/> YES	GEAR DIFFERENTIAL	<input checked="" type="checkbox"/> YES
OIL	<b>Gum</b>	OIL	<b>5000</b> /cst

PINION / T	<b>26</b>	SPUR GEAR / T	<b>110</b>
FINAL DRIVE RATIO	<b>4.2307692307692</b>	ROLLOUT	<b>NaN</b>

FRONT		REAR	
<b>2.7</b>	XRAY SPRINGS	<b>2.7</b>	

<b>500</b>	OIL / CST	<b>500</b>
	LENGTH /mm	

	PRELOAD /mm	
<b>10%</b>	REBOUND %	<b>10%</b>

<input type="checkbox"/> YES <input checked="" type="checkbox"/> NO	FOAM INSERTS	<input type="checkbox"/> YES <input checked="" type="checkbox"/> NO
<input type="checkbox"/> YES <input checked="" type="checkbox"/> NO	O-RING ON SHAFT	<input type="checkbox"/> YES <input checked="" type="checkbox"/> NO

<input checked="" type="checkbox"/> 3 HOLES	PISTONS	<input type="checkbox"/> 3 HOLES
<input type="checkbox"/> 4 HOLES	1.0mm	<input checked="" type="checkbox"/> 4 HOLES
	1.1mm	<input checked="" type="checkbox"/> 4 HOLES
	1.2mm	<input type="checkbox"/> 4 HOLES
	OTHERS	

<b>1.4</b>	THICKNESS/mm	ANTI-ROLL BAR	THICKNESS/mm	<b>1.2</b>
------------	--------------	---------------	--------------	------------

<b>1.4</b>	TIRES	<b>1.2</b>
	INSERTS	
	ADDITIVE	
	ADDITIVE TIMING	

<b>1.4</b>	TIRES	<b>1.2</b>
	INSERTS	
	ADDITIVE	
	ADDITIVE TIMING	

<b>1.4</b>	TIRES	<b>1.2</b>
	INSERTS	
	ADDITIVE	
	ADDITIVE TIMING	

<b>1.4</b>	TIRES	<b>1.2</b>
	INSERTS	
	ADDITIVE	
	ADDITIVE TIMING	



<b>WHEELS</b>	
S <input type="checkbox"/>	M <input type="checkbox"/>
HARDNESS	
S <input type="checkbox"/>	M <input type="checkbox"/>
H <input type="checkbox"/>	

MOTOR	<b>ThunderPower</b>	TIMING
ROTOR		ARMATURE

ESC	<b>MuchMore</b>	BATTERIES	<b>ThunderPower</b>
BODY	<b>PF LTC LW</b>	WING	<b>MR33</b>

BODY	<b>PF LTC LW</b>	WING	<b>MR33</b>
------	------------------	------	-------------

<input checked="" type="checkbox"/> - APPLIED	S-SOFT	M-MEDIUM	H-HARD
---	--------	----------	--------

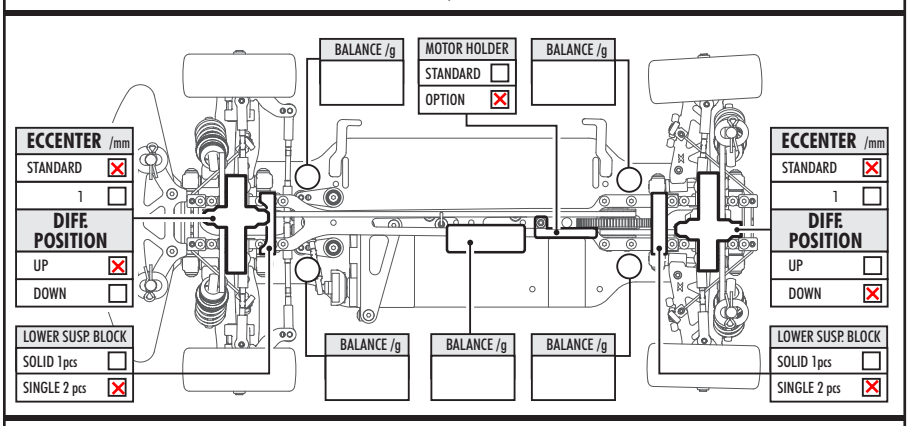
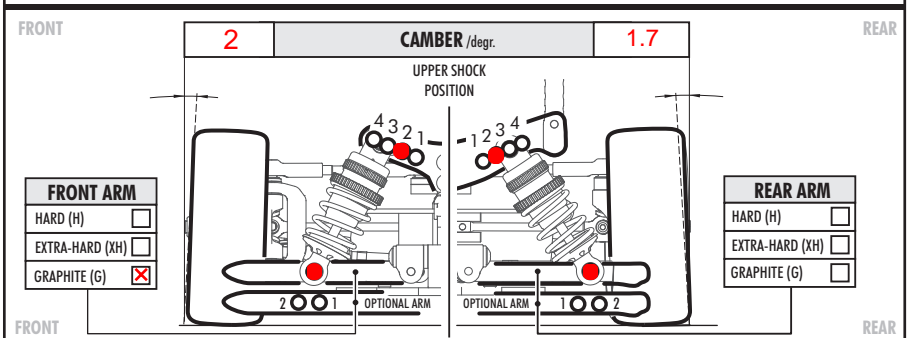
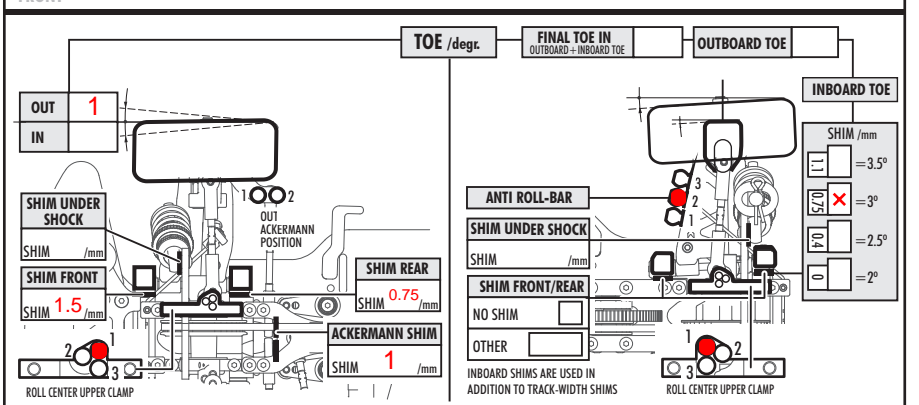
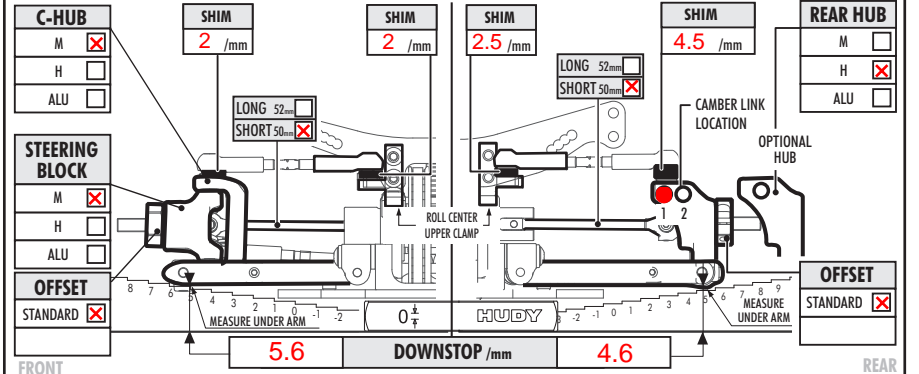
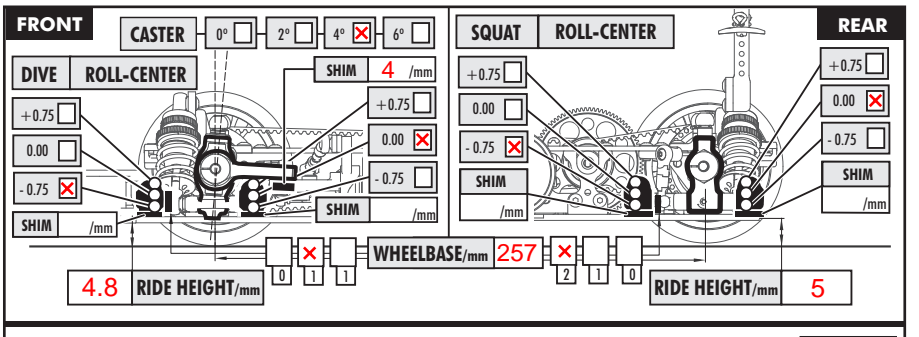

COMMENTS

**ECS** from shafts

VER. 6.0 © XRAY