

# SET-UP SHEET

# XRAY T4

RACE	Roar Asphalt Nationals		
TRACK	Village raceway		
NAME	clparsons123		
CITY / COUNTRY	Royal palm beach, FL USA		
CONTACT	Caparsons15@gmail.com		

DATE	09/05/2013	TEMPERATURE / °F or °C	AIR	TRACK
------	------------	------------------------	-----	-------

QUALIFYING POSITION	BEST LAPTIME /sec	FINAL POSITION	RACE LENGTH /minutes
2nd	13.7	1st	6min

TRACK CONDITION	<input type="checkbox"/> CARPET	<input checked="" type="checkbox"/> ASPHALT	
<input type="checkbox"/> TECHNICAL	<input type="checkbox"/> MIXED	<input checked="" type="checkbox"/> FAST	
TRACTION	<input type="checkbox"/> LOW	<input type="checkbox"/> MEDIUM	<input checked="" type="checkbox"/> HIGH

FRONT	REAR
TRANSMISSION	

SOLID AXLE	<input checked="" type="checkbox"/> YES	BALL DIFFERENTIAL	<input type="checkbox"/> YES
SOLID ONE WAY DIFF.	<input type="checkbox"/> YES		
ONE WAY DIFFERENTIAL	<input type="checkbox"/> YES		

GEAR DIFFERENTIAL	<input type="checkbox"/> YES	GEAR DIFFERENTIAL	<input checked="" type="checkbox"/> YES
OIL		OIL	2000 cst /cst

PINION / T	48	SPUR GEAR / T	100
FINAL DRIVE RATIO	2.08333333333333	ROLLOUT	NaN

FRONT	REAR	
2.7	XRAY SPRINGS	2.5

Xray 450 cst	OIL / CST	Xray 350 cst
	LENGTH /mm	
	PRELOAD /mm	
	REBOUND %	

<input type="checkbox"/> YES	<input checked="" type="checkbox"/> NO	FOAM INSERTS	<input type="checkbox"/> YES	<input checked="" type="checkbox"/> NO
<input type="checkbox"/> YES	<input checked="" type="checkbox"/> NO	O-RING ON SHAFT	<input type="checkbox"/> YES	<input checked="" type="checkbox"/> NO

<input checked="" type="checkbox"/> 3 HOLES	<input type="checkbox"/> 1.0mm	<input type="checkbox"/> 3 HOLES	<input checked="" type="checkbox"/>
<input type="checkbox"/> 4 HOLES	<input checked="" type="checkbox"/> 1.1mm	<input checked="" type="checkbox"/> 4 HOLES	<input type="checkbox"/>
	<input type="checkbox"/> 1.2mm		
OTHERS			

1.4	THICKNESS/mm	ANTI-ROLL BAR	THICKNESS/mm	1.2
-----	--------------	---------------	--------------	-----

TIRES		
LG1 and tire tweak	ADDITIVE	LG1 and tire tweak
	ADDITIVE TIMING	



WHEELS						
S	M	H	HARDNESS			
<input type="checkbox"/>	<input type="checkbox"/>	<input type="checkbox"/>	S	M	H	<input type="checkbox"/>

MOTOR	Fantom ion 4	TIMING	25
ROTOR	grey	ARMATURE	
ESC	Hobby Wing V3	BATTERIES	EAM
BODY	MZD Speed 6	WING	Stock

●  - APPLIED S-SOFT M-MEDIUM H-HARD

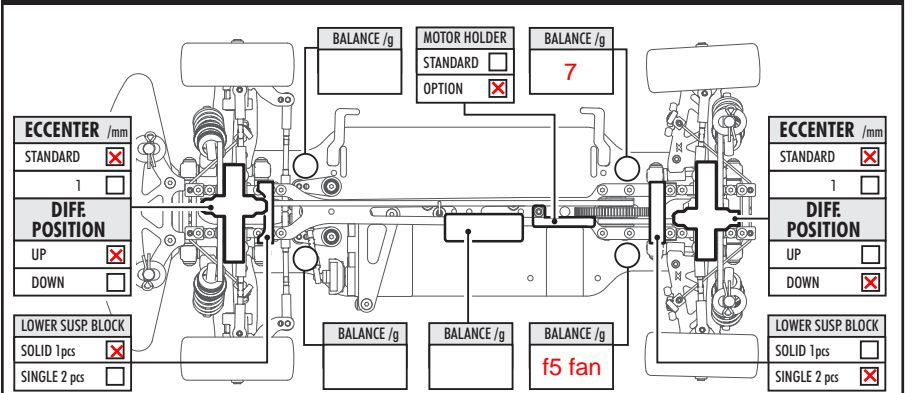
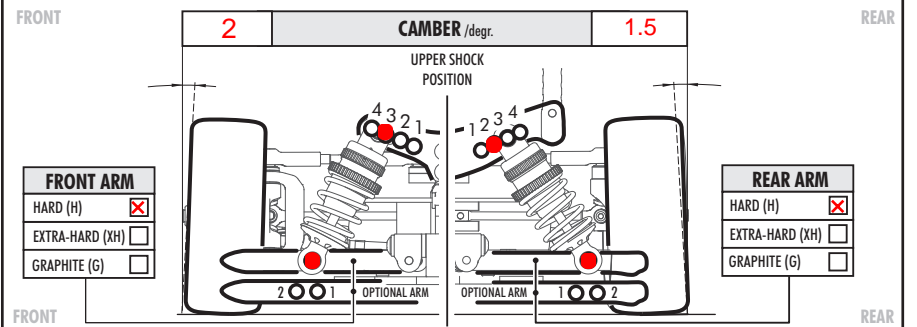
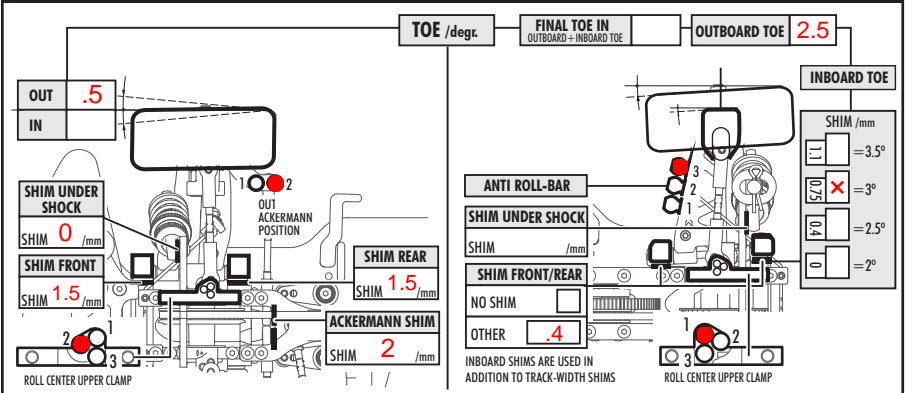
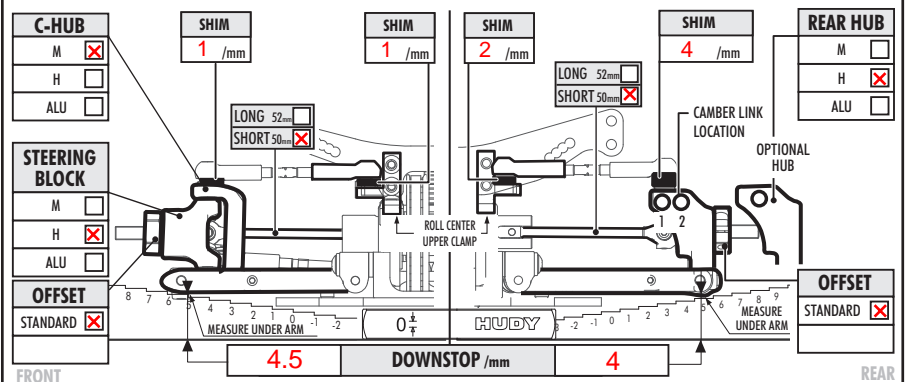
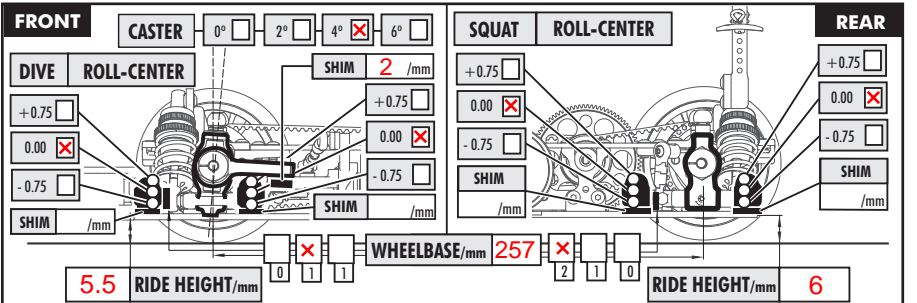

COMMENTS  
RSD ECS in front and RSD Alum out drives

the car was very good on old and new tires .  
when doing tires clean with lg1 then put Tire tweak for 15 minutes. wipe off before going out .  
this worked best for me.

wanted to try hard progressive springs (2.5-2.8) or RSD GREENS