

SET-UP SHEET

XRAY T4

RACE	IIC LAS VEGAS		
TRACK	Ball room		
NAME	clparsons123		
CITY / COUNTRY	Fort myers	USA	
CONTACT	Caparsons15@gmail.com		

DATE	16/10/2013	TEMPERATURE / °F or °C	AIR	TRACK
------	------------	------------------------	-----	-------

QUALIFYING POSITION	BEST LAPTIME /sec	FINAL POSITION	RACE LENGTH /minutes
1st/6th	9.8/9.7	5th/8th	5 min

TRACK CONDITION	<input checked="" type="checkbox"/> CARPET	<input type="checkbox"/> ASPHALT	
	<input type="checkbox"/> TECHNICAL	<input type="checkbox"/> FAST	
TRACTION	<input type="checkbox"/> LOW	<input type="checkbox"/> MEDIUM	<input checked="" type="checkbox"/> HIGH

FRONT	REAR
TRANSMISSION	

SOLID AXLE	<input checked="" type="checkbox"/> YES	BALL DIFFERENTIAL	<input type="checkbox"/> YES
SOLID ONE WAY DIFF.	<input type="checkbox"/> YES		
ONE WAY DIFFERENTIAL	<input type="checkbox"/> YES		

GEAR DIFFERENTIAL	<input type="checkbox"/> YES	GEAR DIFFERENTIAL	<input checked="" type="checkbox"/> YES
OIL		OIL	3000 /cst

PINION / T	51/49	SPUR GEAR / T	100
FINAL DRIVE RATIO	1.9607843137255	ROLLOUT	NaN

FRONT	REAR	
2.7	XRAY SPRINGS	2.5
37.5	OIL / CST	32.5
	LENGTH /mm	
	PRELOAD /mm	
0	REBOUND %	0

<input type="checkbox"/> YES	<input checked="" type="checkbox"/> NO	FOAM INSERTS	<input type="checkbox"/> YES	<input checked="" type="checkbox"/> NO
<input type="checkbox"/> YES	<input checked="" type="checkbox"/> NO	O-RING ON SHAFT	<input type="checkbox"/> YES	<input checked="" type="checkbox"/> NO

<input checked="" type="checkbox"/> 3 HOLES	<input type="checkbox"/> 4 HOLES	PISTONS	1.0mm	<input type="checkbox"/> 3 HOLES	<input checked="" type="checkbox"/> 4 HOLES
<input type="checkbox"/> 3 HOLES	<input checked="" type="checkbox"/> 4 HOLES		1.1mm	<input checked="" type="checkbox"/> 3 HOLES	<input type="checkbox"/> 4 HOLES
			1.2mm	<input type="checkbox"/> 3 HOLES	<input checked="" type="checkbox"/> 4 HOLES
		OTHERS			

1.4	THICKNESS/mm	ANTI-ROLL BAR	THICKNESS/mm	1.3
-----	--------------	---------------	--------------	-----

TIRES	
	INSERTS
	ADDITIVE
	ADDITIVE TIMING



WHEELS						
S <input type="checkbox"/>	M <input type="checkbox"/>	H <input type="checkbox"/>	HARDNESS	S <input type="checkbox"/>	M <input type="checkbox"/>	H <input type="checkbox"/>

MOTOR	apex/ion3	TIMING	full
ROTOR	high torq	ARMATURE	

ESC	TEK GEN 2	BATTERIES	KILLER VOLTS
-----	-----------	-----------	--------------

BODY	LW SPEED 6	WING	STOCK
------	------------	------	-------

● - APPLIED S-SOFT M-MEDIUM H-HARD

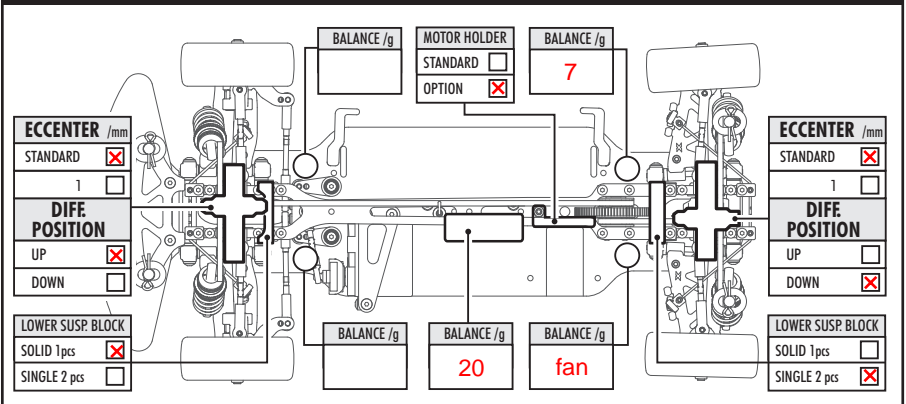
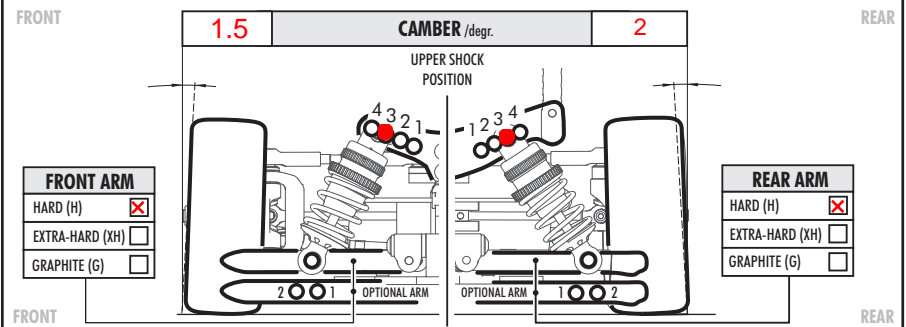
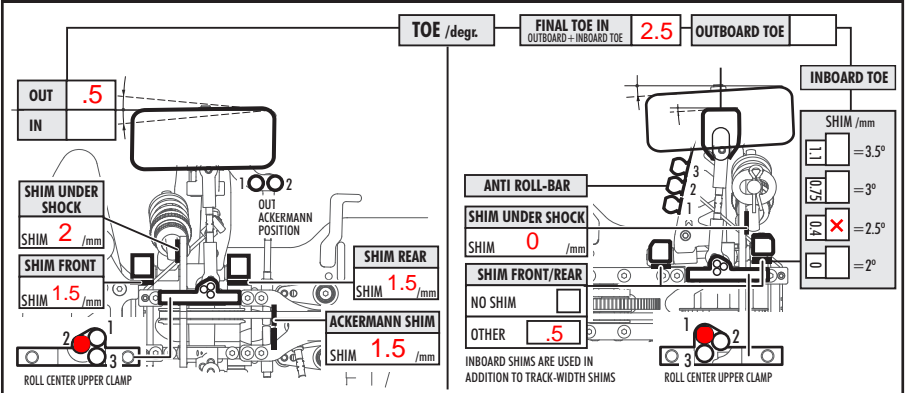
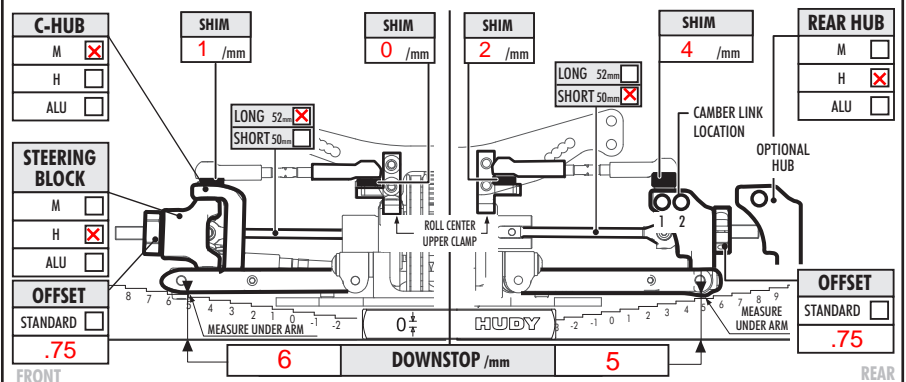
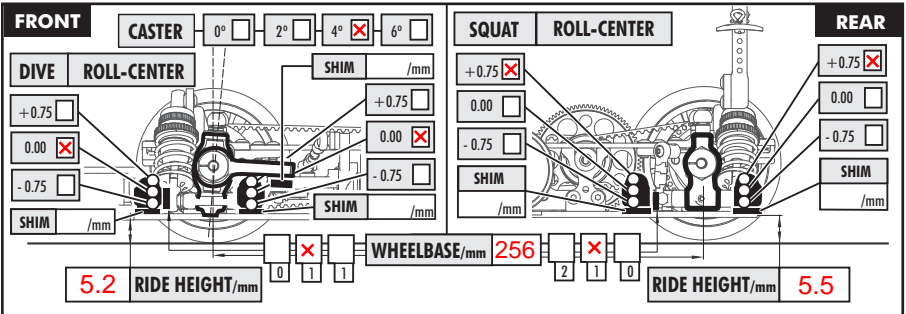

COMMENTS
 this set up was the fastest car on the track in both mains . 13.5 and 17.5 i had rsd pistons ,out drives and ecs's (short) white xray belts and no 2 screws in front of layshaft. this was byfar the best car i have had on carpet. prep tires for 5 minutes .(left prep on to long in 17.5 main is why it traction rolled on the start) very good starting point