

SET-UP SHEET

XRAY T4'14

RACE	Saskatoon WCICS Stock		
TRACK	SARCAR		
NAME	Danny Buck		
CITY / COUNTRY	Saskatoon	Canada	
CONTACT			

DATE	29/09/2014	TEMPERATURE / °F or °C	AIR	TRACK
------	------------	------------------------	-----	-------

QUALIFYING POSITION	BEST LAPTIME /sec	FINAL POSITION	RACE LENGTH /minutes
TQ	10.909	2	5

TRACK CONDITION	<input checked="" type="checkbox"/> CARPET	<input type="checkbox"/> ASPHALT	
<input type="checkbox"/> TECHNICAL	<input checked="" type="checkbox"/> MIXED	<input type="checkbox"/> FAST	
TRACTION	<input type="checkbox"/> LOW	<input checked="" type="checkbox"/> MEDIUM	<input type="checkbox"/> HIGH

FRONT	REAR
TRANSMISSION	

SOLID AXLE	<input checked="" type="checkbox"/> YES	BALL DIFFERENTIAL	<input type="checkbox"/> YES
SOLID ONE WAY DIFF.	<input type="checkbox"/> YES		
ONE WAY DIFFERENTIAL	<input type="checkbox"/> YES		

GEAR DIFFERENTIAL	<input type="checkbox"/> YES	GEAR DIFFERENTIAL	<input checked="" type="checkbox"/> YES
OIL		OIL	2k /Cst

PINION / T	46	SPUR GEAR / T	100
FINAL DRIVE RATIO	2.1739130434783	ROLLOUT	NaN

FRONT	REAR
-------	------

2.5	XRAY SPRINGS	2.5
-----	--------------	-----

400	OIL / CST	350
-----	-----------	-----

	LENGTH /mm	
--	------------	--

	PRELOAD /mm	
--	-------------	--

0	REBOUND %	0
---	-----------	---

<input type="checkbox"/> YES <input checked="" type="checkbox"/> NO	FOAM INSERTS	<input type="checkbox"/> YES <input checked="" type="checkbox"/> NO
<input type="checkbox"/> YES <input checked="" type="checkbox"/> NO	O-RING ON SHAFT	<input type="checkbox"/> YES <input checked="" type="checkbox"/> NO

<input type="checkbox"/> 3 HOLES	PISTONS	<input type="checkbox"/> 3 HOLES
<input checked="" type="checkbox"/> 4 HOLES	1.0mm	<input checked="" type="checkbox"/> 4 HOLES
	1.1mm	
	1.2mm	
	OTHERS	

1.4	THICKNESS/mm	ANTI-ROLL BAR	THICKNESS/mm	1.2
-----	--------------	---------------	--------------	-----

Sweep	TIRES	32EXP
-------	-------	-------

SXT 3.0	INSERTS	SXT 3.0
---------	---------	---------

10	ADDITIVE TIMING	10
----	-----------------	----

FRONT LEFT	FRONT RIGHT	REAR LEFT	REAR RIGHT
TREATED AREA			

WHEELS	
S <input type="checkbox"/> M <input type="checkbox"/> H <input type="checkbox"/>	HARDNESS

MOTOR	EAM D4	TIMING	60
ROTOR		ARMATURE	

ESC	ORCA VXX	BATTERIES	ORCA 7500
-----	----------	-----------	-----------

BODY	Speed 6 LW	WING	
------	------------	------	--

- APPLIED S-SOFT M-MEDIUM H-HARD

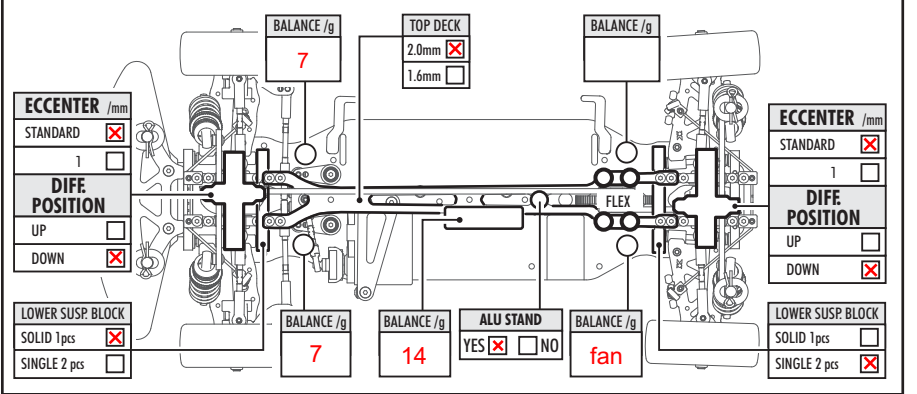
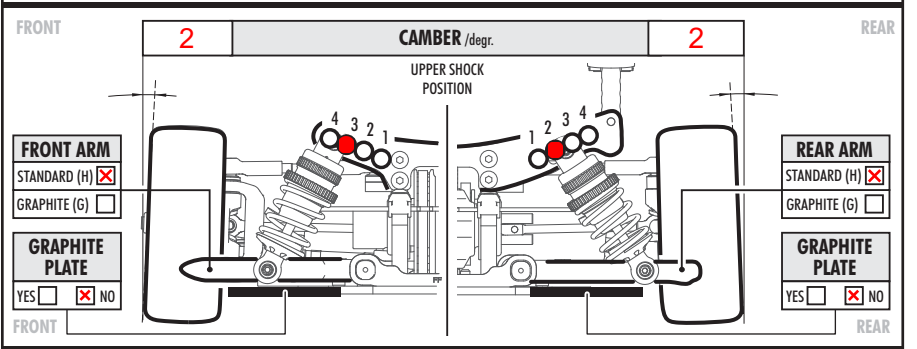
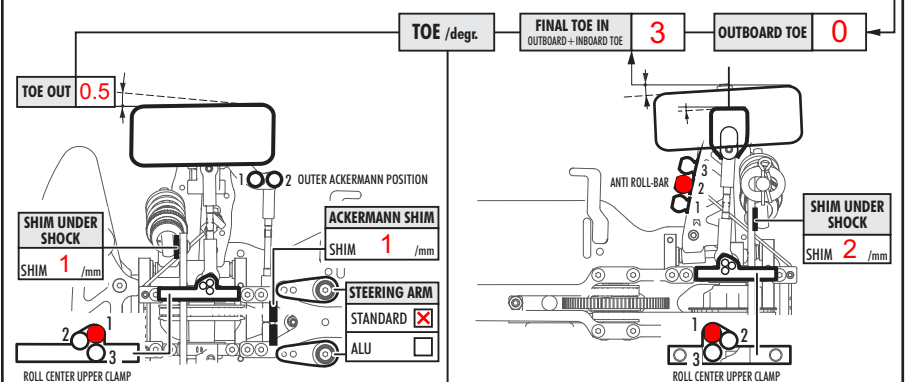
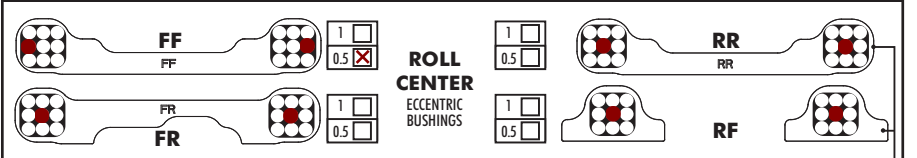
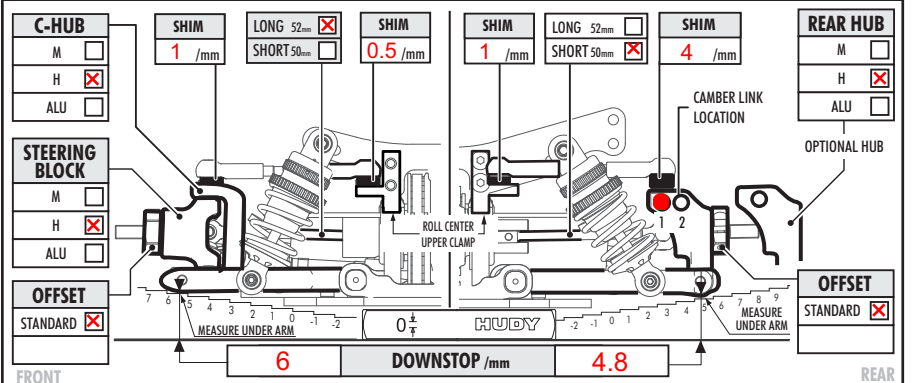
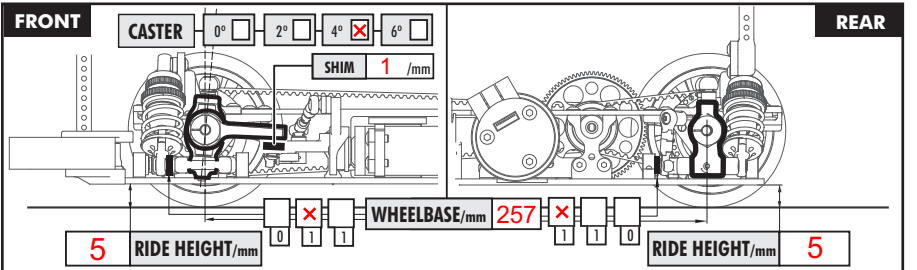

COMMENTS
Should have used a front diff in the main. Needed more rotation into the corner.