

SET-UP SHEET

XRAY T4'14

RACE	DHI Cup 2014		
TRACK	Stadium Arena Fyn		
NAME	Alexander Hagberg		
CITY / COUNTRY	Odense	Denmark	
CONTACT	alexander.hagberg@gmail.com		

DATE	13/01/2014	TEMPERATURE / °F or °C	AIR	TRACK
------	------------	------------------------	-----	-------

QUALIFYING POSITION	BEST LAPTIME /sec	FINAL POSITION	RACE LENGTH /minutes
4	11.9	4	5

TRACK CONDITION	<input checked="" type="checkbox"/> CARPET	<input type="checkbox"/> ASPHALT	
<input type="checkbox"/> TECHNICAL	<input checked="" type="checkbox"/> MIXED	<input type="checkbox"/> FAST	
TRACTION	<input type="checkbox"/> LOW	<input checked="" type="checkbox"/> MEDIUM	<input type="checkbox"/> HIGH

FRONT	REAR
TRANSMISSION	

SOLID AXLE	<input checked="" type="checkbox"/> YES	BALL DIFFERENTIAL	<input type="checkbox"/> YES
SOLID ONE WAY DIFF.	<input type="checkbox"/> YES		
ONE WAY DIFFERENTIAL	<input type="checkbox"/> YES		

GEAR DIFFERENTIAL	<input type="checkbox"/> YES	GEAR DIFFERENTIAL	<input checked="" type="checkbox"/> YES
OIL		OIL	5000 /Cst

PINION / T	27	SPUR GEAR / T	110
FINAL DRIVE RATIO	4.0740740740741	ROLLOUT	NaN

FRONT	REAR
-------	------

2.5-2.8	XRAY SPRINGS	2.6
---------	--------------	-----

400	OIL / CST	400
-----	-----------	-----

	LENGTH /mm	
--	------------	--

	PRELOAD /mm	
--	-------------	--

0	REBOUND %	0
---	-----------	---

<input type="checkbox"/> YES	<input checked="" type="checkbox"/> NO	FOAM INSERTS	<input type="checkbox"/> YES	<input checked="" type="checkbox"/> NO
<input type="checkbox"/> YES	<input checked="" type="checkbox"/> NO	O-RING ON SHAFT	<input type="checkbox"/> YES	<input checked="" type="checkbox"/> NO

<input type="checkbox"/> 3 HOLES	<input checked="" type="checkbox"/> 4 HOLES	PISTONS	<input type="checkbox"/> 3 HOLES	<input checked="" type="checkbox"/> 4 HOLES
		1.0mm		
		1.1mm		
		1.2mm		
		OTHERS		

1.4	THICKNESS/mm	ANTI-ROLL BAR	THICKNESS/mm	1.3
-----	--------------	---------------	--------------	-----

LRP CPX	TIRES	LRP CPX
---------	-------	---------

	INSERTS	
--	---------	--

HUDY	ADDITIVE	HUDY
10	ADDITIVE TIMING	10



WHEELS	
S <input type="checkbox"/>	M <input type="checkbox"/> H <input type="checkbox"/>
HARDNESS	
S <input type="checkbox"/>	M <input type="checkbox"/> H <input type="checkbox"/>

MOTOR	ORCA TX 5.0T	TIMING	STD
ROTOR	12.5	ARMATURE	

ESC	ORCA VXX	BATTERIES	ORCA 6200 90C
-----	----------	-----------	---------------

BODY	PF SP6 LW	WING	PF HARD STD
------	-----------	------	-------------

● - APPLIED S-SOFT M-MEDIUM H-HARD

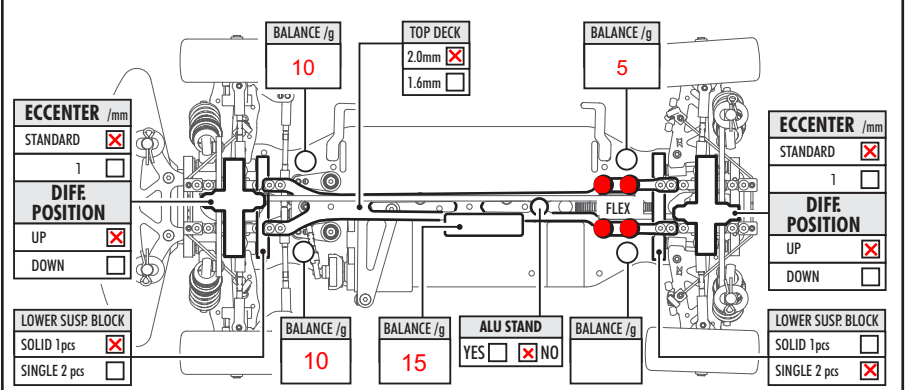
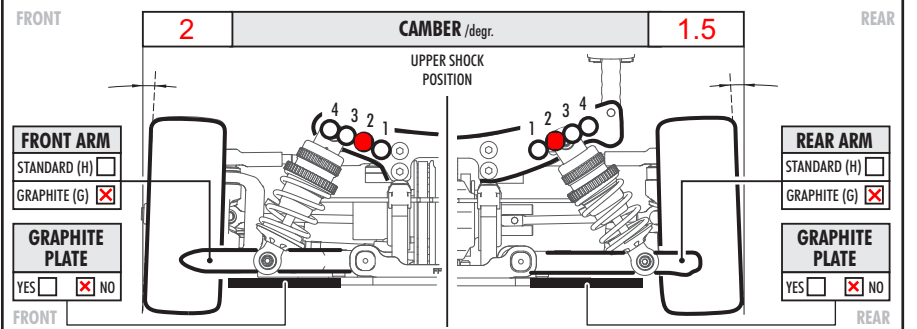
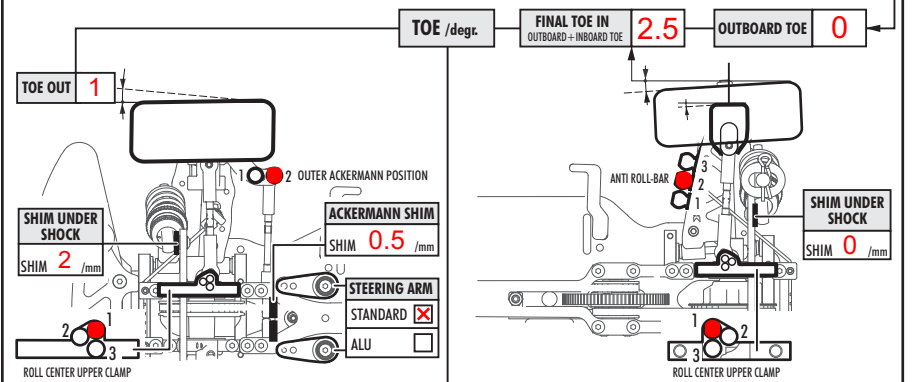
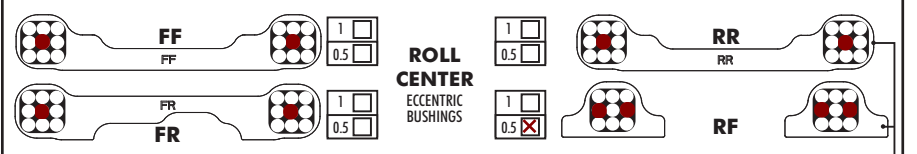
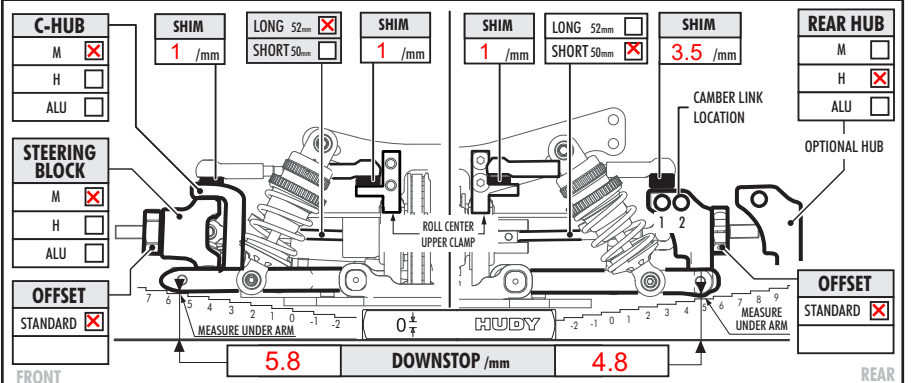
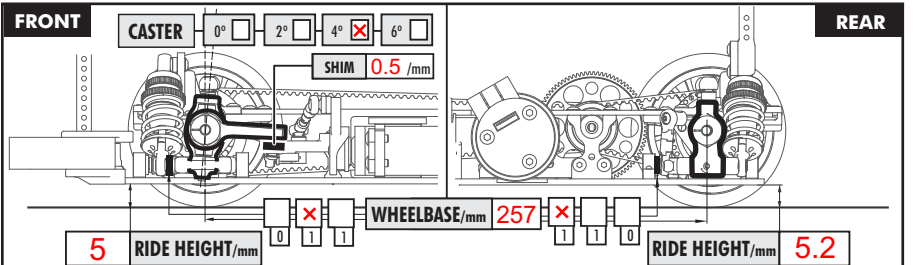

COMMENTS
ECS front driveshafts
HUDY alu servo horn 293491