

1/10 ELECTRIC TOURING CAR FWD

XRAY X4F



INSTRUCTION MANUAL
FOR X4F'27 EDITION

BEFORE YOU START

This is a high-competition, high-quality RC car intended for persons aged 16 years and older with previous experience building and operating RC model racing cars. This is not a toy; it is a precision racing model. This model racing car is not intended for use by beginners, inexperienced customers, or by children without direct supervision of a responsible, knowledgeable adult. If you DO NOT fulfill these requirements, please return the kit in unused and unassembled form back to the shop where you have purchased it.

Before building and operating your XRAY, **YOU MUST** read through all of the operating instructions and instruction manual and fully understand them to get the maximum enjoyment and prevent unnecessary damage.

Read carefully and fully understand the instructions before beginning assembly.

CUSTOMER SUPPORT

We have made every effort to make these instructions as easy to understand as possible. However, if you have any difficulties, problems, or questions, please DO NOT hesitate to contact the XRAY support team at info@teamxray.com. Also, please visit our Web site at www.teamxray.com to find the latest updates, set-up information, option parts, and many other goodies. We pride ourselves on taking excellent care of our customers.

You can join thousands of XRAY fans and enthusiasts in our online community at:

www.teamxray.com

Make sure you review this entire manual, download and use set-up book from the web, and examine all details carefully. If for some reason you decide this is not what you wanted or expected, **DO NOT continue any further**. Your hobby dealer can not accept your kit for return or exchange after it has been partially or fully assembled.

Contents of the box may differ from pictures. In line with our policy of continuous product development, the exact specifications of the kit may vary without prior notice.

XRAY Europe

K Vystavisku 6992
91101 Trenčín
Slovakia, EUROPE
Phone: 421-32-7401100
Fax: 421-32-7401109
E-mail: info@teamxray.com

XRAY USA

RC America, 2030 Century Center Blvd #15 Irving, TX
75062
USA
Phone: (214) 744-2400
Fax: (214) 744-2401
E-mail: xray@rcamerica.com

FAILURE TO FOLLOW THESE INSTRUCTIONS WILL BE CONSIDERED AS ABUSE AND/OR NEGLIGENCE.

SAFETY PRECAUTIONS

Contains:

LEAD (CAS 7439-92-1) ANTIMONY (CAS 7440-36-0)

WARNING: This product contains a chemical known to the state of California to cause cancer and birth defects or other reproductive harm.

CAUTION: CANCER HAZARD

Contains lead, a listed carcinogen. Lead is harmful if ingested. Wash thoroughly after using. DO NOT use product while eating, drinking or using tobacco products. May cause chronic effects to gastrointestinal tract, CNS, kidneys, and blood. **MAY CAUSE BIRTH DEFECTS.**

When building, using and/or operating this model always wear protective glasses and gloves.

Take appropriate safety precautions prior to operating this model. You are responsible for this model's assembly and safe operation! Please read the instruction manual before building and operating this model and follow all safety precautions. Always keep the instruction manual at hand for quick reference, even after completing the assembly. Use only genuine and original authentic XRAY parts for maximum performance. Using any third party parts on

this model will void guaranty immediately.

Improper operation may cause personal and/or property damage. XRAY and its distributors have no control over damage resulting from shipping, improper construction, or improper usage. XRAY assumes and accepts no responsibility for personal and/or property damages resulting from the use of improper building materials, equipment and operations. By purchasing any item produced by XRAY, the buyer expressly warrants that he/she is in compliance with all applicable federal, state and local laws and regulation regarding the purchase, ownership and use of the item. The buyer expressly agrees to indemnify and hold harmless XRAY for all claims resulting directly or indirectly from the purchase, ownership or use of the product. By the act of assembling or operating this product, the user accepts all resulting liability. If the buyer is not prepared to accept this liability, then he/she should return this kit in new, unassembled, and unused condition to the place of purchase.



IMPORTANT NOTES - GENERAL

- This product is not suitable for children under 16 years of age without the direct supervision of a responsible and knowledgeable adult.
- Carefully read all manufacturers warnings and cautions for any parts used in the construction and use of your model.
- Assemble this kit only in places away from the reach of very small children.
- First-time builders and users should seek advice from people who have building experience in order to assemble the model correctly and to allow the model to reach its performance potential.
- Exercise care when using tools and sharp instruments.
- Take care when building, as some parts may have sharp edges.
- Keep small parts out of reach of small children. Children must not be allowed to put any parts in their mouth, or pull vinyl bag over their head.
- Read and follow instructions supplied with paints and/or cement, if used (not included in kit).
- Immediately after using your model, DO NOT touch equipment on the model such as the motor and speed controller, because they generate high temperatures. You may seriously burn yourself seriously touching them.
- Follow the operating instructions for the radio equipment at all times.
- DO NOT put fingers or any objects inside rotating and moving parts, as this may cause damage or serious injury as your finger, hair, clothes, etc. may get caught.
- Be sure that your operating frequency is clear before turning on or running your model, and never share the same frequency with somebody else at the same time. Ensure that others are aware of the operating frequency you are using and when you are using it.
- Use a transmitter designed for ground use with RC cars. Make sure that no one else is using the same frequency as yours in your operating area. Using the same frequency at the same time, whether it is driving, flying or sailing, can cause loss of control of the RC model, resulting in a serious accident.
- Always turn on your transmitter before you turn on the receiver in the car. Always turn off the receiver before turning your transmitter off.
- Keep the wheels of the model off the ground when checking the operation of the radio equipment.
- Disconnect the battery pack before storing your model.
- When learning to operate your model, go to an area that has no obstacles that can

damage your model if your model suffers a collision.

- Remove any sand, mud, dirt, grass or water before putting your model away.
- If the model behaves strangely, immediately stop the model, check and clear the problem.
- To prevent any serious personal injury and/or damage to property, be responsible when operating all remote controlled models.
- The model car is not intended for use on public places and roads or areas where its operation can conflict with or disrupt pedestrian or vehicular traffic.
- Because the model car is controlled by radio, it is subject to radio interference from many sources that are beyond your control. Since radio interference can cause momentary loss of control, always allow a safety margin in all directions around the model in order to prevent collisions.
- DO NOT use your model:
 - Near real cars, animals, or people that are unaware that an RC car is being driven.
 - In places where children and people gather
 - In residential districts and parks
 - In limited indoor spaces
 - In wet conditions
 - In the street
 - In areas where loud noises can disturb others, such as hospitals and residential areas.
 - At night or anytime your line of sight to the model may be obstructed or impaired in any way.

To prevent any serious personal injury and/or damage to property, please be responsible when operating all remote controlled models.

XRAY

IMPORTANT NOTES – ELECTRICAL

- Insulate any exposed electrical wiring (using heat shrink tubing or electrical tape) to prevent dangerous short circuits. Take maximum care in wiring, connecting and insulating cables. Make sure cables are always connected securely. Check connectors for if they become loose. And if so, reconnect them securely. Never use RC models with damaged wires. A damaged wire is extremely dangerous, and can cause short-circuits resulting in fire. Please have wires repaired at your local hobby shop.
- Low battery power will result in loss of control. Loss of control can occur due to a weak battery in either the transmitter or the receiver. Weak running battery may also result in an out of control car if your car's receiver power is supplied by the running battery. Stop operation immediately if the car starts to slow down.
- When not using RC model, always disconnect and remove battery.
- DO NOT disassemble battery or cut battery cables. If the running battery short-circuits, approximately 300W of electricity can be discharged, leading to fire or burns. Never disassemble battery or cut battery cables.
- Use a recommended charger for the receiver and transmitter batteries and follow the instructions correctly. Over-charging, incorrect charging, or using inferior chargers can cause the batteries to become dangerously hot. Recharge battery when necessary. Continual recharging may damage battery and, in the worst case, could build up heat

leading to fire. If battery becomes extremely hot during recharging, please ask your local hobby shop for check and/or repair and/or replacement.

- Regularly check the charger for potential hazards such as damage to the cable, plug, casing or other defects. Ensure that any damage is rectified before using the charger again. Modifying the charger may cause short-circuit or overcharging leading to a serious accident. Therefore DO NOT modify the charger.
- Always unplug charger when recharging is finished.
- DO NOT recharge battery while battery is still warm. After use, battery retains heat. Wait until it cools down before charging.
- DO NOT allow any metal part to short circuit the receiver batteries or other electrical/electronic device on the model.
- Immediately stop running if your RC model gets wet as may cause short circuit.
- Please dispose of batteries responsibly. Never put batteries into fire.

R/C & BUILDING TIPS

- Make sure all fasteners are properly tightened. Check them periodically.
- Make sure that chassis screws DO NOT protrude from the chassis.
- For the best performance, it is very important that great care is taken to ensure the free movement of all parts.
- Clean all ball-bearings so they move very easily and freely.
- Tap or pre-thread the plastic parts when threading screws.
- Self-tapping screws cut threads into the parts when being tightened.
DO NOT use excessive force when tightening the self-tapping screws because you may strip out the thread in the plastic. We recommended you stop tightening a screw when you feel some resistance.
- Ask your local hobby shop for any advice.

Please support your local hobby shop. We at XRAY Model Racing Cars support all local hobby dealers. Therefore we ask you, if at all possible, to purchase XRAY products at your hobby dealer and give them your support like we do. If you have difficulty finding XRAY products, please check out www.teamxray.com to get advice, or contact us via email at info@teamxray.com, or contact the XRAY distributor in your country.

WARRANTY

XRAY guarantees this model kit to be free from defects in both material and workmanship within 30 days of purchase. The total monetary value under warranty will in no case exceed the cost of the original kit purchased. This warranty does not cover any components damaged by use or modification or as a result of wear. Part or parts missing from this kit must be reported within 30 days of purchase. No part or parts will be sent under warranty without proof of purchase. Should you find a defective or missing part, contact the local distributor. Service and customer support will be provided through local hobby store where you have purchased the kit, therefore make sure to purchase any XRAY products at your local hobby store. This model racing car is considered to be a high-performance racing vehicle. As such this vehicle will be used in an extreme range of conditions and situations, all which may cause premature wear or failure of any component. XRAY has no control over usage of vehicles once they leave the dealer, therefore XRAY can only offer warranty against all manufacturer's defects in materials, workmanship, and assembly at point of sale and before use. No warranties are expressed or implied that cover damage caused by what is considered normal use, or cover or imply how long any model cars' components or electronic components will last before requiring replacement.

Due to the high performance level of this model car you will need to periodically maintain and replace consumable components. Any and all warranty coverage will not cover replacement of any part or component damaged by neglect, abuse, or improper or unreasonable use. This includes but is not limited to damage from crashing, chemical and/or water damage, excessive moisture, improper or no maintenance, or user modifications which compromise the integrity of components. Warranty will not cover components that are considered consumable on RC vehicles. XRAY does not pay nor refund shipping on any

component sent to XRAY or its distributors for warranty. XRAY reserves the right to make the final determination of the warranty status of any component or part.

Limitations of Liability

XRAY makes no other warranties expressed or implied. XRAY shall not be liable for any loss, injury or damages, whether direct, indirect, special, incidental, or consequential, arising from the use, misuse, or abuse of this product and/or any product or accessory required to operate this product. In no case shall XRAY's liability exceed the monetary value of this product.

Take adequate safety precautions prior to operating this model. You are responsible for this model's assembly and safe operation.

Disregard of the any of the above cautions may lead to accidents, personal injury, or property damage. XRAY MODEL RACING CARS assumes no responsibility for any injury, damage, or misuse of this product during assembly or operation, nor any addictions that may arise from the use of this product.

All rights reserved.

QUALITY CERTIFICATE

XRAY MODEL RACING CARS uses only the highest quality materials, the best compounds for molded parts and the most sophisticated manufacturing processes of TQM (Total Quality Management). We guarantee that all parts of a newly-purchased kit are manufactured with the highest regard to quality. However, due to the many factors inherent in model racecar competition, we cannot guarantee any parts once you start racing the car. Products which

have been worn out, abused, neglected or improperly operated will not be covered under warranty.

We wish you enjoyment of this high-quality and high-performance RC car and wish you best success on the track!

In line with our policy of continuous product development, the exact specifications of the kit may vary. In the unlikely event of any problems with your new kit, you should contact the model shop where you purchased it, quoting the part number.

We do reserve all rights to change any specification without prior notice. All rights reserved.

TOOLS REQUIRED



Ball Joint Wrench (HUDY #181110)



Pocket Hobby Knife (HUDY #188981)



Special Tool for turnbuckles, nuts (HUDY #181090)



Turnbuckle Wrench 4mm (HUDY #181040)



Turnbuckle Wrench 3mm (HUDY #181030)



HUDY Tweezers Straight (HUDY #188970)



HUDY Tweezers Curved (HUDY #188971)



Allen 1.5mm (#111545 - HUDY EXCLUSIVE Limited Edition)



Allen 2.0mm (#112045 - HUDY EXCLUSIVE Limited Edition)



Allen 2.5mm (#112545 - HUDY EXCLUSIVE Limited Edition)



Ball Allen 2.5mm (#132545 - HUDY EXCLUSIVE Limited Edition)



Allen 3.0mm (#113045 - HUDY EXCLUSIVE Limited Edition)



Socket 5.5mm (#175535 - HUDY EXCLUSIVE Limited Edition)



Socket 7.0mm (#177035 - HUDY EXCLUSIVE Limited Edition)

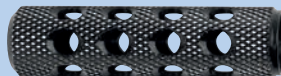

Reamer (#107602 - HUDY EXCLUSIVE Limited Edition)



Professional Multi Tool (HUDY #183011)



Scissors (HUDY #188990)



Blade Hobby Knife (HUDY #188980)



Alu Shock Pliers (#183070 HUDY ALU SHOCK PLIERS)

INCLUDED

350cSt (#106335)
HUDY Premium Silicone Oils



OIL
350
cSt

500.000cSt (#106650)
HUDY Premium Silicone Oils



OIL
500K
cSt

(HUDY #106210)
Premium Graphite Grease



GR
GRAPHITE
GREASE

EQUIPMENT REQUIRED

<p>Transmitter</p>	<p>Receiver</p>	<p>Speed Controller</p>	<p>Steering Servo</p>
<p>Electric Motor</p>	<p>Pinion Gear with Setscrew</p>	<p>LiPo Battery</p>	<p>Battery Charger</p>
<p>Lexan™ Paint</p>	<p>Wheels & Tires & Inserts (HUDY #803041 SLICK PRECUT)</p>	<p>190mm Bodyshell</p>	<p>Double-sided Tape (HUDY #107875)</p>
<p>Fibre Tape (HUDY #107870)</p>	<p>Bearing Oil (HUDY #106230)</p>	<p>Threadlock</p>	<p>CA glue</p>

BUILD TIPS & NOTES



Alexander Hagberg (Factory Driver)

When a QR CODE is found in the instruction manual, scan the code to be directed to an online video that explains that feature or adjustment in more detail. Make sure to watch all of the instructional videos to get the most performance out of your car.

VIDEO TECH TIP



NOTE!

Please note that the videos are made specifically for the X4, but will contain very good information that may apply to the X4F as well.



SAMPLE OF OPTIONAL PARTS

#30XXXX	TYPE1	OPTION 1
#30XXXX	TYPE1	OPTION 2
#30XXXX	TYPE1	INCLUDED
#30XXXX	TYPE1	OPTION 3

XRAY offers wide range of OPTIONAL tuning parts which are listed in a table like this. Please refer to the exploded view of each main section to verify which part is included in the kit while all other parts are available only as an optional part and must be purchased separately.

COLOR INDICATIONS

At the beginning of each section is an exploded view of the parts to be assembled. There is also a list of all the parts and part numbers that are related to the assembly of that section.

The part descriptions are color-coded to make it easier for you to identify the source of a part. Here are what the different colors mean:

304911

STYLE A - indicates parts that are included in the bag marked for the section.

301029

STYLE B - indicates parts that are included in the box.

304902

STYLE C - indicates parts that are already assembled from previous steps.

302242

STYLE D - indicates parts that are optional.

CHASSIS PREPARATION



VIDEO TECH TIP



CHASSIS PREPARATION

TIP To protect and seal edges of carbon parts, sand edges smooth and then apply CA glue. Do this for: chassis edges and countersunk holes.

XRAY uses the highest quality USA-made carbon fiber sheets available on the market. The carbon fiber sheets are pressed, and this production technique may result in slight variations in each sheet's thickness and flatness. The carbon manufacturer cannot and does not guarantee perfect uniformity as it is impossible to ensure each plate's perfect flatness with such thin material thicknesses.

These tolerances for thickness and flatness are taken into consideration when designing our XRAY cars and parts. Minor irregularities in the carbon fiber parts will not affect the performance of XRAY vehicles once assembled with the other components. While an individual carbon fiber part itself may not lay perfectly flat, rest assured that the assembled vehicle will still perform as designed and intended.

TOP
REAR

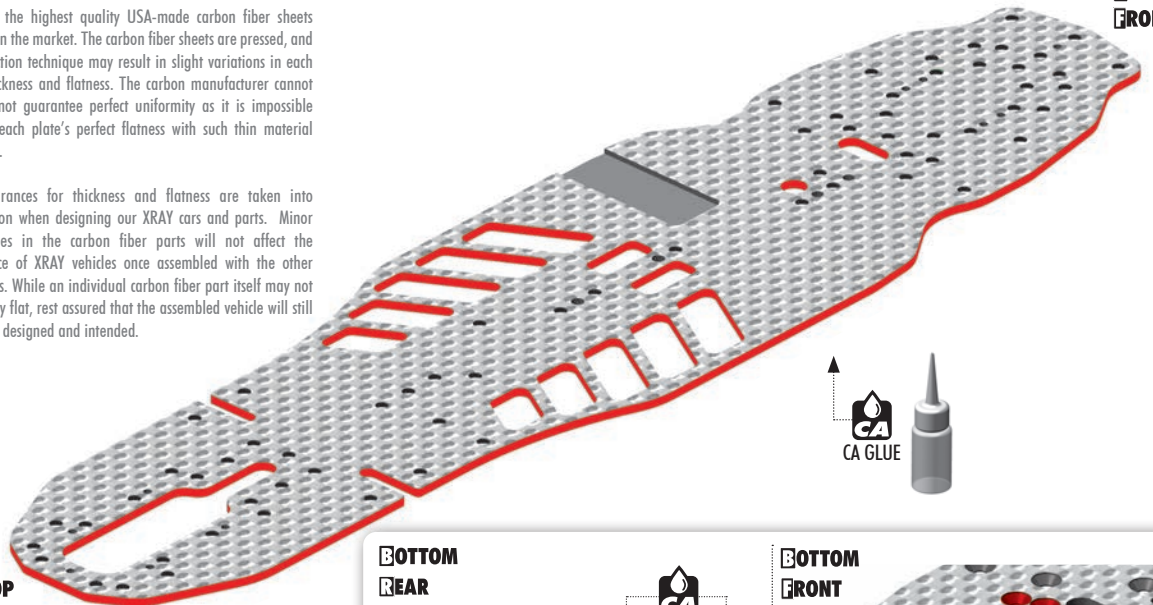

TOP
FRONT



BOTTOM
REAR

Apply only a bit of CA glue in the countersunk holes.

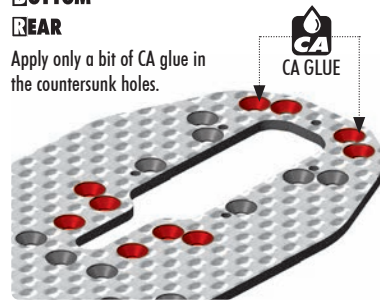

BOTTOM
FRONT

Apply only a bit of CA glue in the countersunk holes.

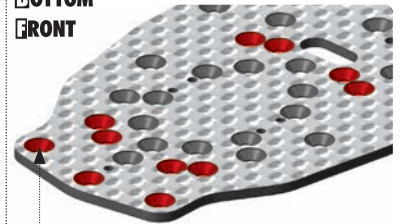

TIP

All ball-bearings are factory pre-oiled. Regularly service, clean and lubricate all ball-bearings with **HUDY Bearing Oil (#106230)**. Replace any bearings that develop a "gritty" feeling to prevent inefficiency and avoid rear axle bearing blowouts.

Make sure to use only original XRAY ball-bearings, which all have specific tolerances, axial and radial play, and are all individually selected. Using 3rd party ball-bearings may result in failures and damage to other parts.



1. GEAR DIFFERENTIAL



#304932
GRAPHITE GEAR DIFF BEVEL &
SATELLITE GEARS (2+4)

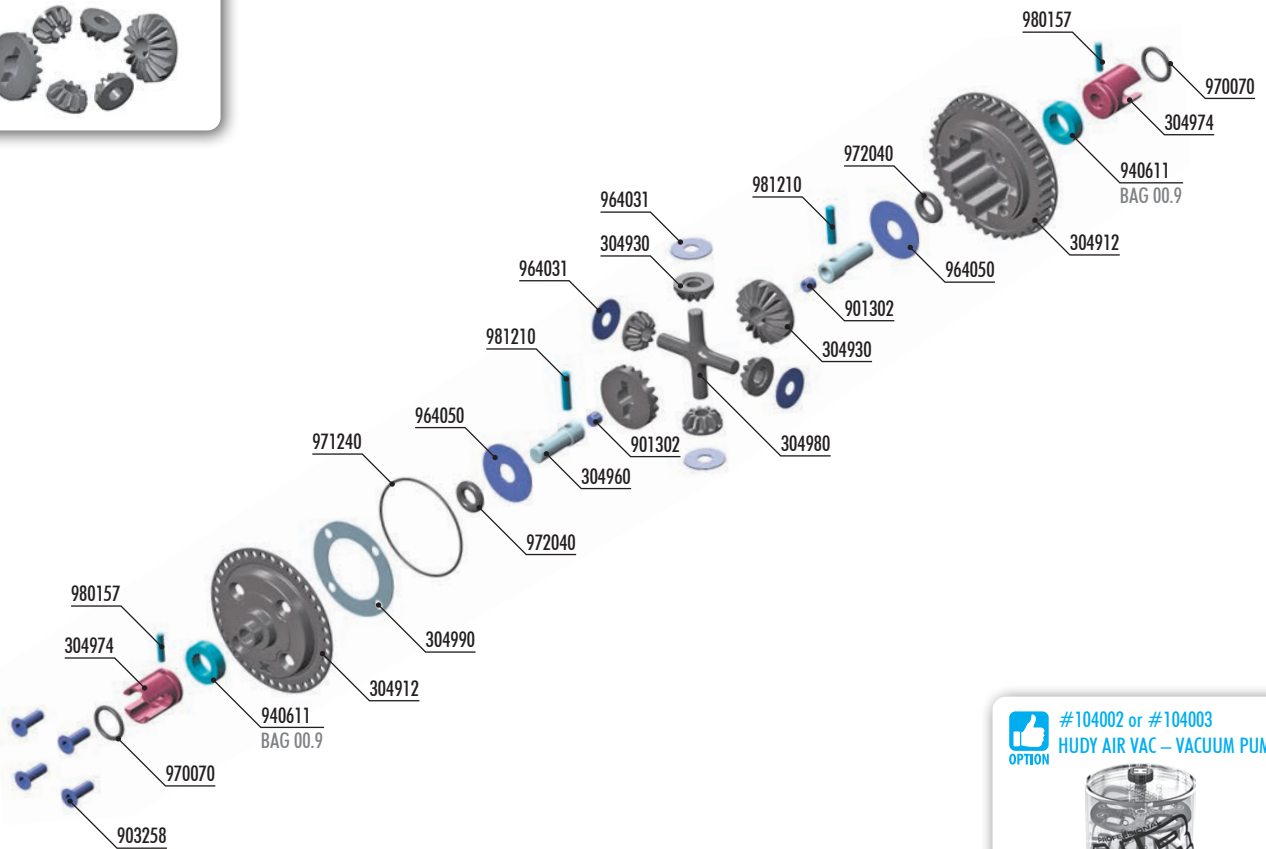

#104002 or #104003
HUDY AIR VAC – VACUUM PUMP



BAG

01

- | | | | |
|--------|---|--------|-----------------------------|
| 304903 | X4 BB GEAR DIFFERENTIAL FOR UNI BULKHEADS - SET | 970070 | O-RING 7x1 (10) |
| 304912 | X4 COMPOSITE GEAR DIFF. CASE 38T PULLEY & COVER FOR UNI BULKHEADS | 971240 | SILICONE O-RING 24x0.7 (10) |
| 304930 | COMPOSITE GEAR DIFF BEVEL & SATELLITE GEARS (2+4) | 972040 | SILICONE O-RING 4x2 (10) |
| 304960 | STEEL ADAPTER FOR GEAR DIFF OUTDRIVE (2) | 980157 | PIN 1.5x7.3 (10) |
| 304974 | STEEL GEAR DIFF OUTDRIVE FOR SMALL BEARING - HUDY SPRING STEEL™ (2) | 981210 | PIN 2x10 (10) |
| 304980 | COMPOSITE GEAR DIFF CROSS PIN | | |
| 304990 | DIFF GASKET (4) | | |
| 901302 | HEX SCREW SB M3x2.5 (10) | | |
| 903258 | HEX SCREW SFH M2.5x8 (10) | | |
| 940611 | BALL-BEARING 6x10x3 LOW RADIAL PLAY RUBBER SEALED - OIL (2) | | |
| 964031 | WASHER S 3.5x10x0.2 (10) | | |
| 964050 | WASHER S 5x15x0.3 (10) | | |

Numbers in parentheses () refer to quantities when purchased separately.

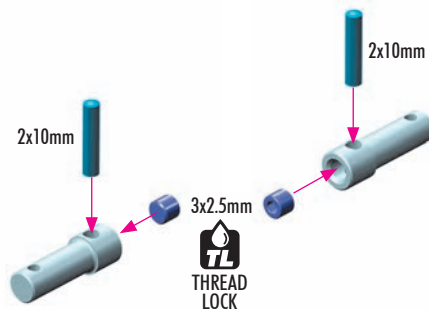

ASSEMBLED VIEW

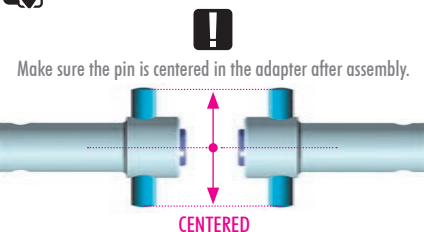

1. GEAR DIFFERENTIAL

Carefully remove the gears from the frame, and remove all excess plastic flash.



OIL

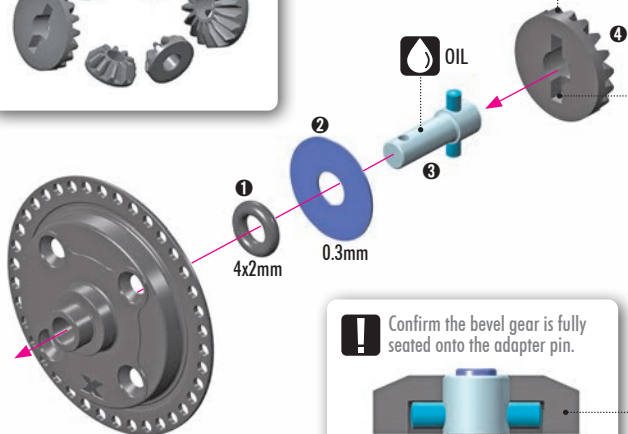

Confirm the bevel gear is fully seated onto the adapter pin.

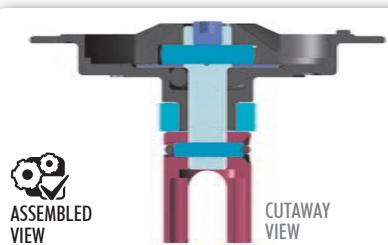
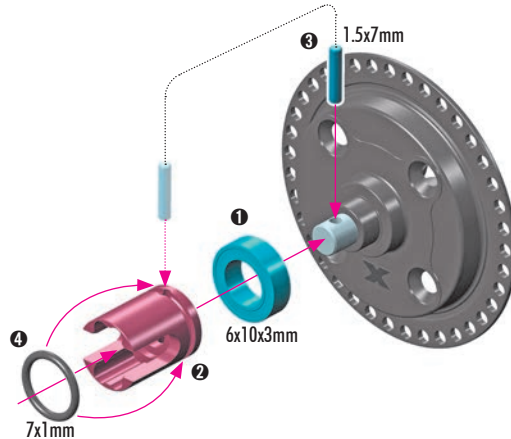
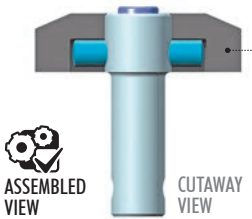

2x 940611
BB 6x10x3



2x 964050
S 5x15x0.3



2x 970070
0.7x1



2x 972040
0.4x2



2x 980157
P 1.5x7

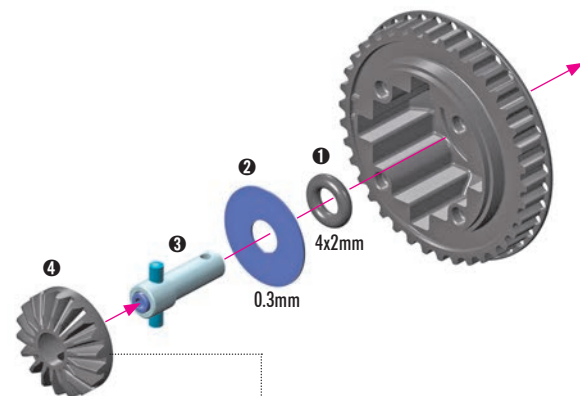

It is important that gear diff bevel sits fully into the pin.

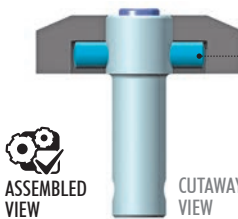

#304932
OPTION GRAPHITE GEAR DIFF BEVEL & SATELLITE GEARS (2+4)

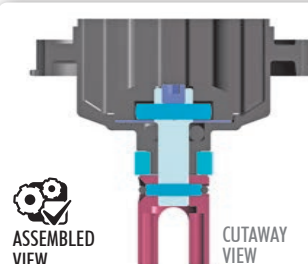
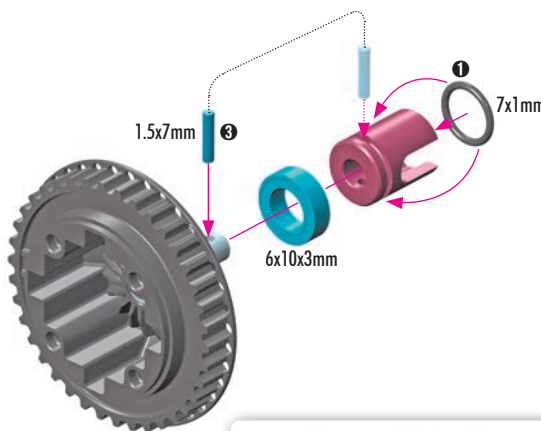

4x 964031
S 3.5x10x0.2

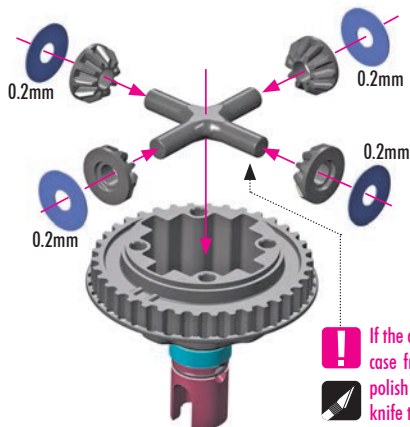

If the cross pin DOES NOT slide into the diff case freely, use fine sand paper to lightly polish the ends of the cross, or use a hobby knife to carefully remove any flashing.

#304932
OPTION GRAPHITE GEAR DIFF BEVEL & SATELLITE GEARS (2+4)



1. GEAR DIFFERENTIAL

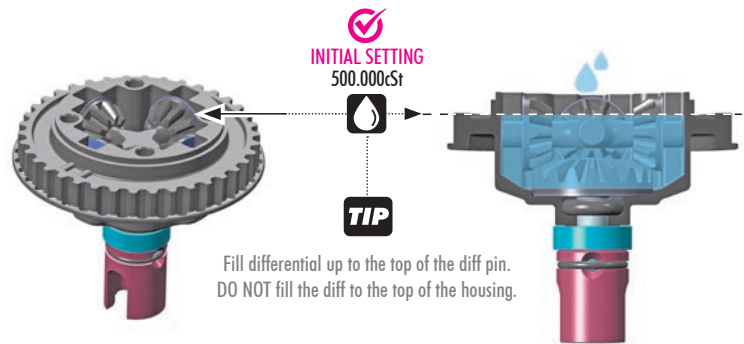

TO ENSURE YOU HAVE THE SAME AMOUNT OF OIL FROM REBUILD TO REBUILD, DO THE FOLLOWING:

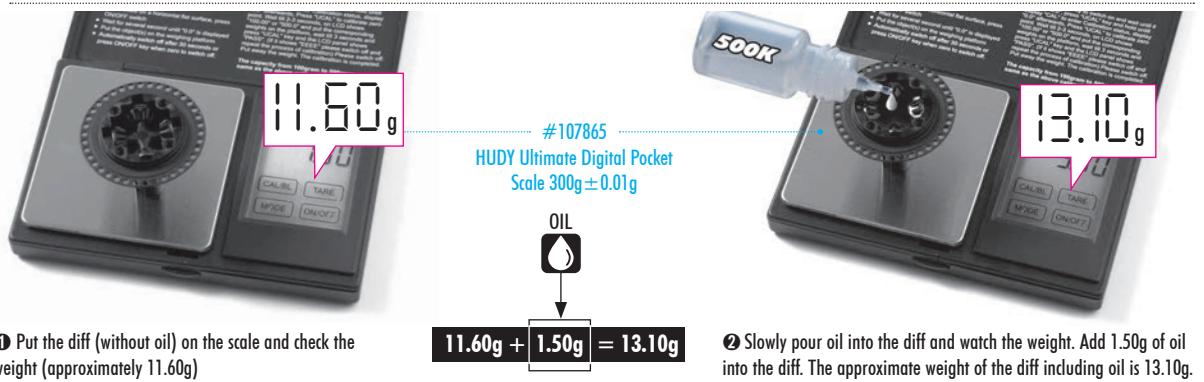

TIP



TIPS FOR DIFFERENTIALS

TIP



However, if the oil is too light, it could generate the same effect like the car has no traction. Therefore it is very important to choose the correct oil very carefully. We recommend using lighter oil first, then try heavier oil to better understand the effect on the car's behavior at the track. Choose the oil accordingly.



TIP To make sure that all the air is removed from the diff oil, we recommend using the HUDY Air Vac.

OPTION #104002 or #104003
HUDY AIR VAC – VACUUM PUMP

100.000cSt (HUDY #106610)

150.000cSt (HUDY #106615)

200.000cSt (HUDY #106620)

300.000cSt (HUDY #106630)

500.000cSt (HUDY #106650)

1 000.000cSt (HUDY #106692)

2 000.000cSt (HUDY #106694)

Lower viscosity oil will increase steering but reduce traction.

LOWER VISCOSITY



INITIAL SETTING

HIGHER VISCOSITY

Higher viscosity oil will improve forward traction and increase stability, but reduces steering.

TIP To make the front differential thicker, you can use #106200 HUDY Magic Cleaning Gum instead of oil.

IMPORTANT!

Using cleaning gum instead of oil in the gear differential can lead to gear breakage because the gears are working under dry conditions.



VIDEO TECH TIP



DIFFERENTIAL

1. GEAR DIFFERENTIAL

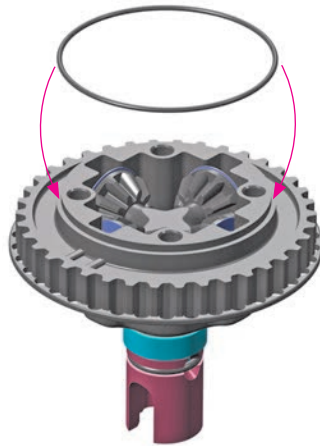
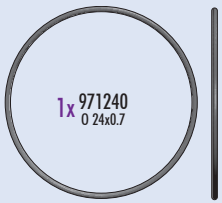

After disassembling the gear diff, the large O-ring may have an increased size and may be more difficult to re-install. We recommend either inserting the old O-ring carefully in the diff cover, or installing a new O-ring if the old one cannot be made to fit properly.



4x 903258
SFH M2.5x8

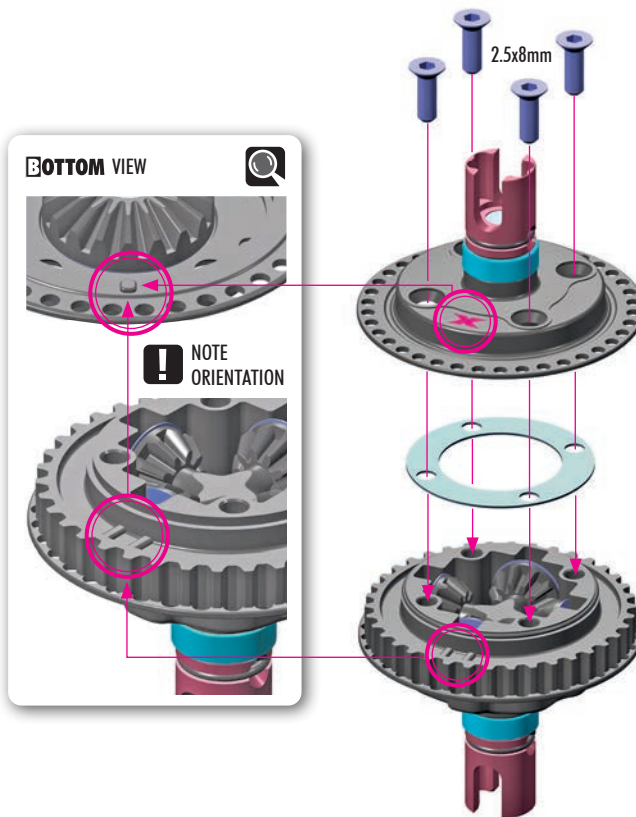

Tighten the screws equally but **DO NOT** tighten them completely.

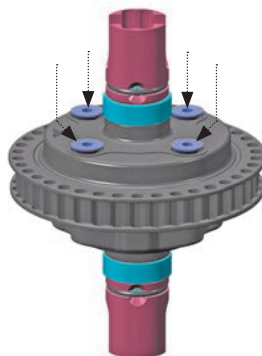

Finish tightening in this order.

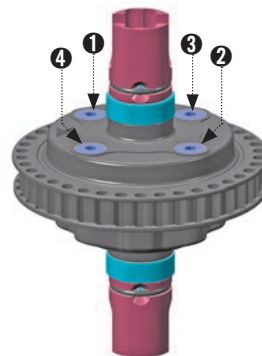

2. FRONT & REAR SUSPENSION

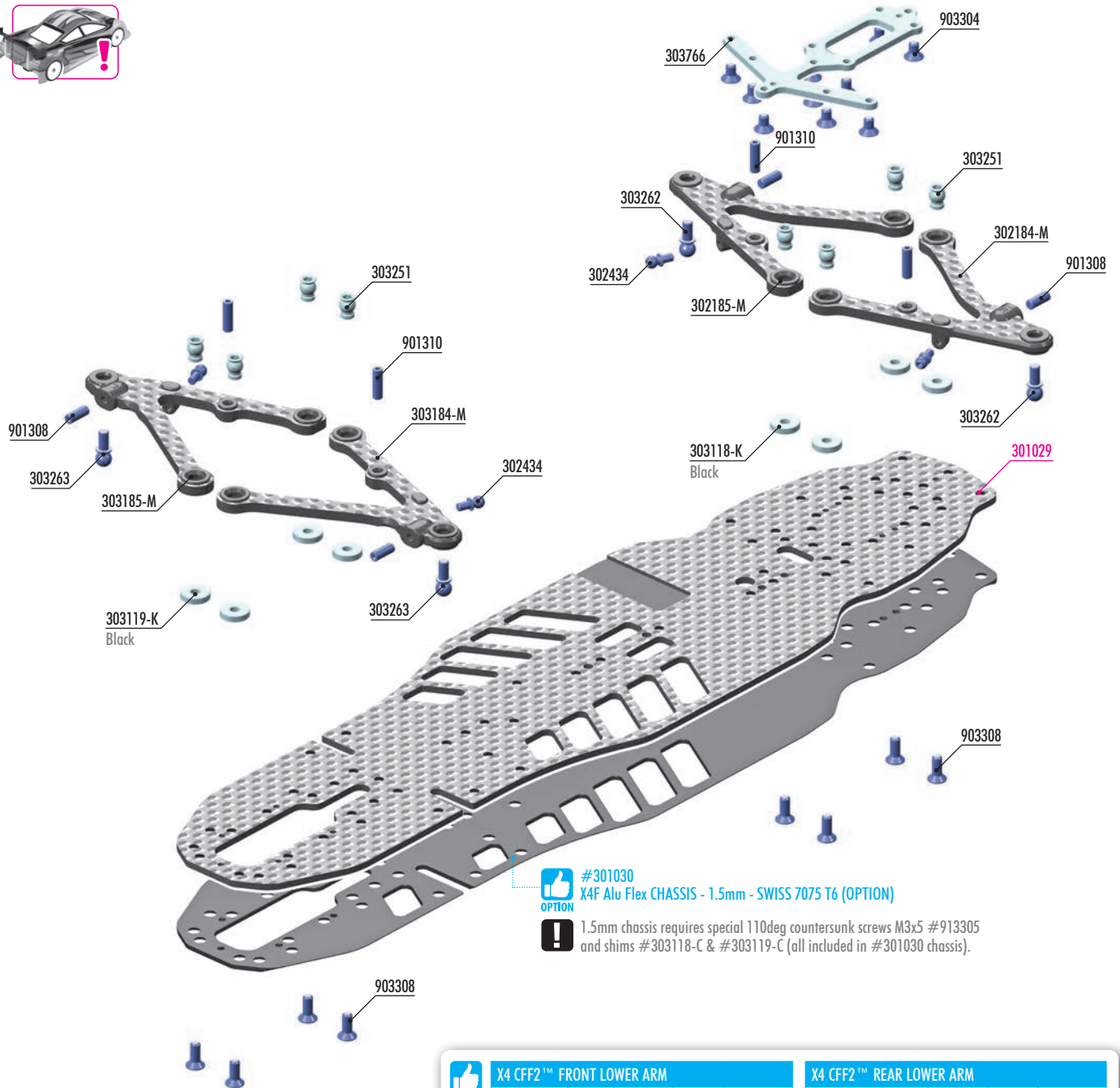

#301030
X4F Alu Flex CHASSIS - 1.5mm - SWISS 7075 T6 (OPTION)



1.5mm chassis requires special 110deg countersunk screws M3x5 #913305 and shims #303118-C & #303119-C (all included in #301030 chassis).



X4 CFF2™ FRONT LOWER ARM				
#302187-M	LEFT	MEDIUM		OPTION
#302186-M	RIGHT	MEDIUM		OPTION
#302187-H	LEFT	HARD		OPTION
#302186-H	RIGHT	HARD		OPTION
#302185-M	LEFT	MEDIUM	SHORT	INCLUDED
#302184-M	RIGHT	MEDIUM	SHORT	INCLUDED

X4 CFF2™ REAR LOWER ARM				
#303187-M	LEFT	MEDIUM		OPTION
#303186-M	RIGHT	MEDIUM		OPTION
#303187-H	LEFT	HARD		OPTION
#303186-H	RIGHT	HARD		OPTION
#303185-M	LEFT	MEDIUM	SHORT	INCLUDED
#303184-M	RIGHT	MEDIUM	SHORT	INCLUDED



VIDEO TECH TIP

CHASSIS OPTIONS

BAG

02

- 302184-M X4 CFF2™ FRONT LOWER ARM - MEDIUM - SHORT - RIGHT
- 302185-M X4 CFF2™ FRONT LOWER ARM - MEDIUM - SHORT - LEFT
- 302434 ANTI-ROLL BAR STEEL BALL END 3.8mm WITH M2.5x4mm THREAD (2)
- 303118-K ALU SHIM 3x9x1.0mm - BLACK (10)
- 303119-K ALU SHIM 3x9x2.0mm - BLACK (10)
- 303184-M X4 CFF2™ REAR LOWER ARM - MEDIUM - SHORT - RIGHT
- 303185-M X4 CFF2™ REAR LOWER ARM - MEDIUM - SHORT - LEFT
- 303251 X4 LOWER ARM BALL UNIVERSAL 4.9mm WITH HEX - HUDY SPRING STEEL™ (2)
- 303262 X4 PIVOT BALL 4.9mm WITH M3x5.5mm THREAD - HUDY SPRING STEEL™ (2)
- 303263 X4 PIVOT BALL 4.9mm WITH M3x6.0mm THREAD - HUDY SPRING STEEL™ (2)
- 303766 X4F ALU CHASSIS BRACE - SWISS 7075 T6

- 901308 HEX SCREW SB M3x8 (10)
- 901310 HEX SCREW SB M3x10 (10)
- 903304 HEX SCREW SFH M3x4 (10)
- 903308 HEX SCREW SFH M3x8 (10)

301029 CARBON CHASSIS 2.2mm

Numbers in parentheses () refer to quantities when purchased separately.

2. FRONT & REAR SUSPENSION

REAR SUSPENSION ARMS

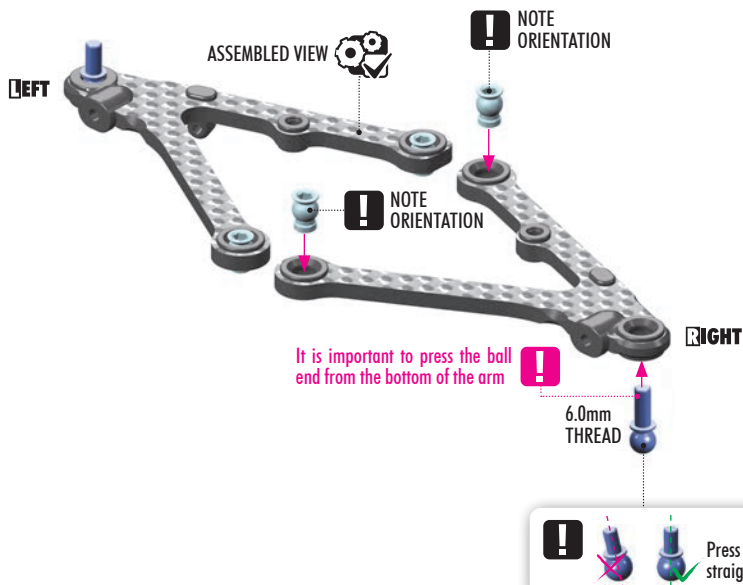

! Install the pivot balls with #183011 - HUDY Multi Tool

Remove #183013 pins.

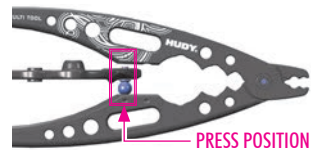

PRESS POSITION

To make sure that the pivot ball is pressed into the arm correctly, remove the pins from the HUDY Multi Tool and use the exact press position like shown on the picture. This way the ball will never go through the arm and will NOT create any excessive play.



2x 901308 SB M3x8



2x 901310 SB M3x10



VIDEO TECH TIP



LOWER ARMS

REAR SUSPENSION ARMS

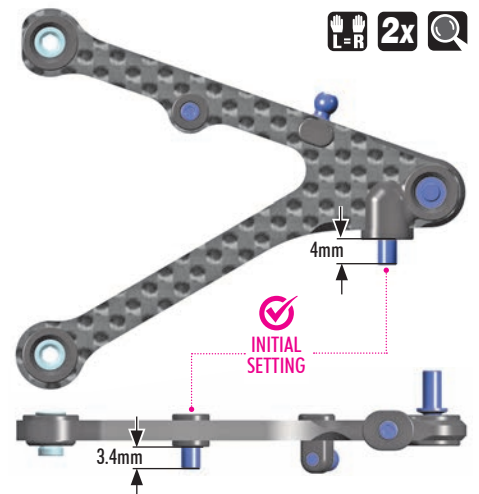
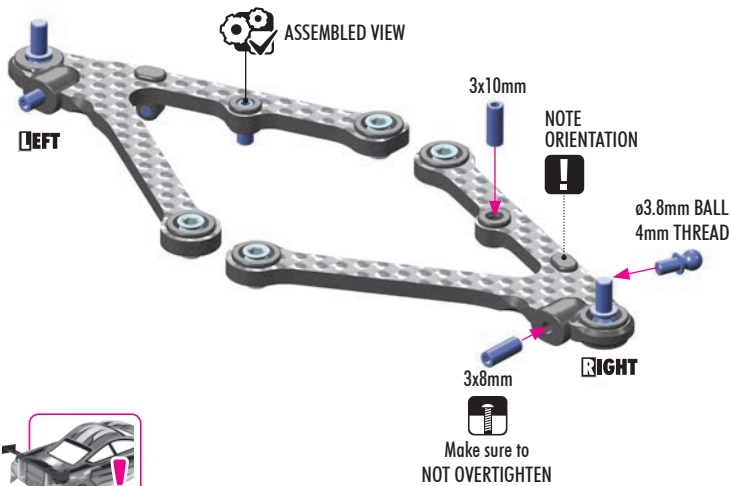

FRONT SUSPENSION ARMS

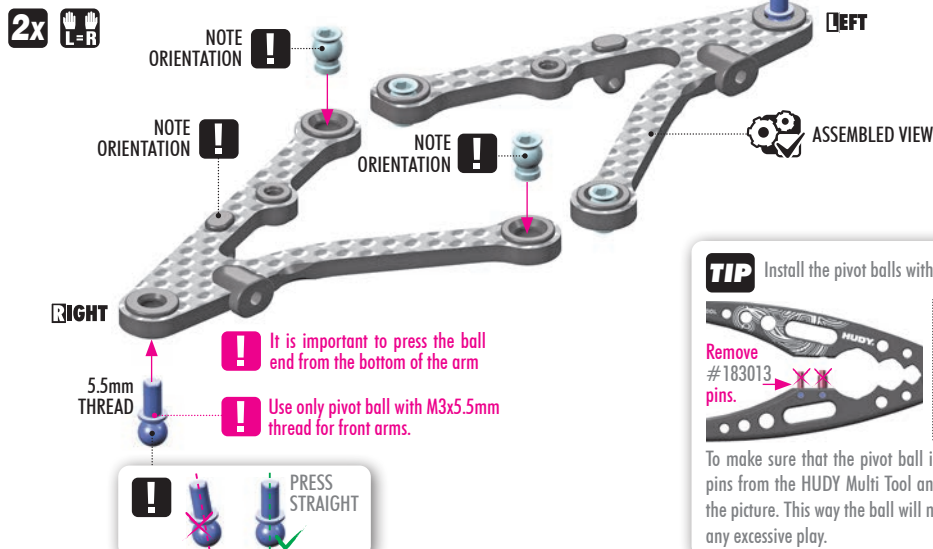

TIP Install the pivot balls with #183011 - HUDY Multi Tool.

Remove #183013 pins.

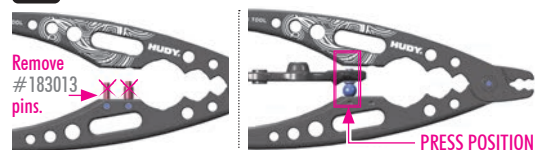

PRESS POSITION

To make sure that the pivot ball is pressed into the arm correctly, remove the pins from the HUDY Multi Tool and use the exact press position like shown on the picture. This way the ball will never go through the arm and will NOT create any excessive play.

2. FRONT & REAR SUSPENSION



2x 901308
SB M3x8



2x 901310
SB M3x10

FRONT SUSPENSION ARMS

2x L=R

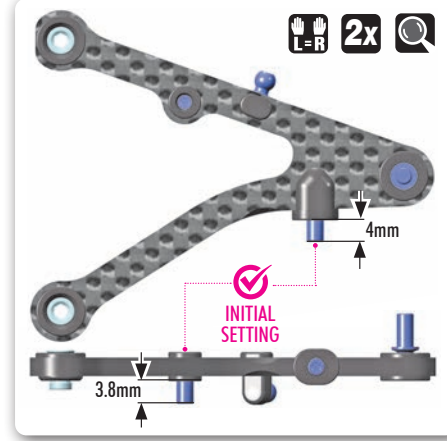
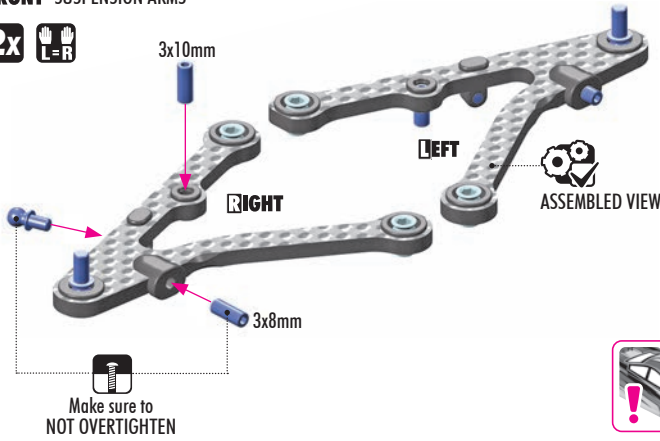

4x 303118-K
SHIM 3x9x1



4x 303119-K
SHIM 3x9x2



8x 903308
SFH M3x8

1.5mm Chassis Note: When installing the special 303119-C, make sure shim has the correct orientation. The larger chamfer should face the chassis plate to allow the screw to be fully tightened.

OPTION #303118-C ALU SHIM 3x9x1.0mm - DEEPER COUNTERSUNK (10)

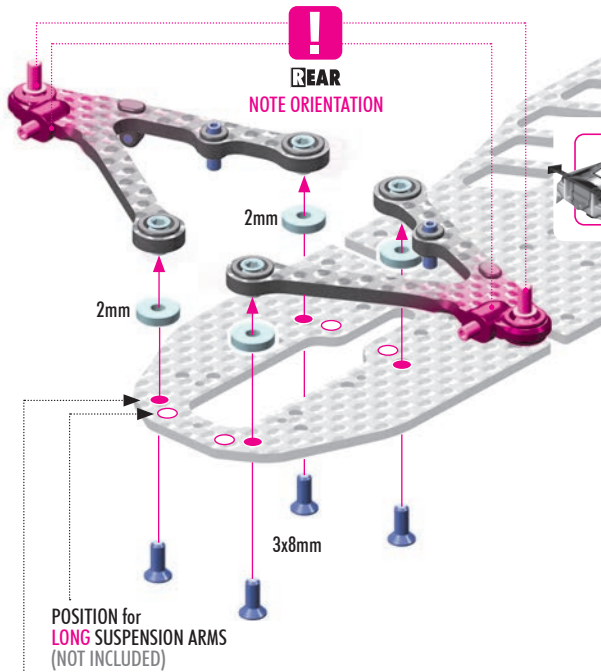

POSITION for LONG SUSPENSION ARMS (NOT INCLUDED)

POSITION for SHORT SUSPENSION ARMS

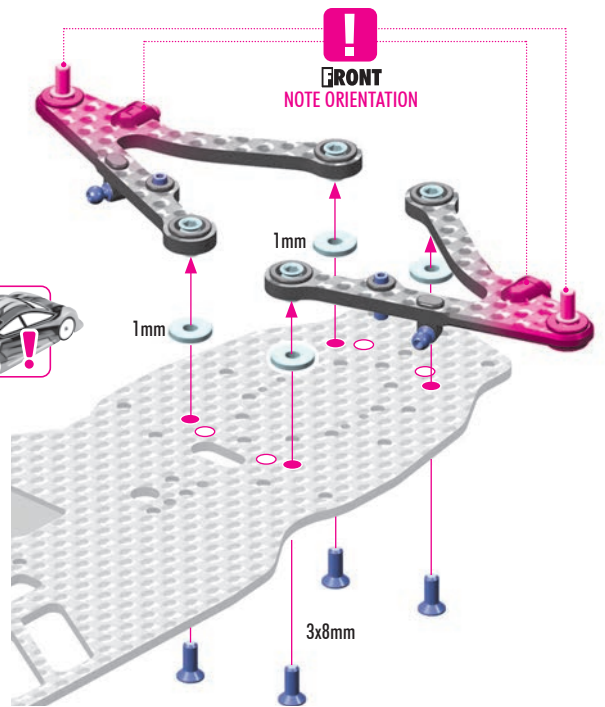

VIDEO TECH TIP



ROLL-CENTER



CHASSIS ALTERNATIVES

ROLL-CENTER ADJUSTMENT

RAISING THE LOWER ARMS will raise the car's roll center. Raising the lower arms both front and rear will free up the car, and will make it initially more responsive. Side bite will be decreased. A higher roll center is typically recommended for asphalt racing.

LOWERING THE LOWER ARMS will lower the car's roll center. Lowering both the front and rear arms will lock in the car more, and will make it initially less responsive. Side bite will be increased. A lower roll center is typically recommended for carpet racing.

OPTION	X4 CFF2™ REAR LOWER ARM			
	#303187-M	LEFT	MEDIUM	OPTION
	#303186-M	RIGHT	MEDIUM	OPTION
	#303187-H	LEFT	HARD	OPTION
	#303186-H	RIGHT	HARD	OPTION
	#303185-M	LEFT	MEDIUM	SHORT INCLUDED
	#303184-M	RIGHT	MEDIUM	SHORT INCLUDED

SHORT: Short arms are more aggressive, allowing more (INCLUDED) chassis roll and increasing initial steering. Short arms will improve steering in low traction and tight technical tracks, but will be more difficult to drive.

LONG: The standard length arms provide neutral and balanced handling with moderate initial steering and good cornering speed.

OPTION	X4 CFF2™ FRONT LOWER ARM			
	#302187-M	LEFT	MEDIUM	OPTION
	#302186-M	RIGHT	MEDIUM	OPTION
	#302187-H	LEFT	HARD	OPTION
	#302186-H	RIGHT	HARD	OPTION
	#302185-M	LEFT	MEDIUM	SHORT INCLUDED
	#302184-M	RIGHT	MEDIUM	SHORT INCLUDED

MEDIUM: Maximum mechanical traction, recommended for low to medium traction surfaces.

HARD: Reduced mechanical traction creates more rotation on very-high traction surfaces like ETS carpet and indoor asphalt.

2. FRONT & REAR SUSPENSION



11x 903304 SFH M3x4



NOTE ORIENTATION 
The countersunk side for the screw should face downward.

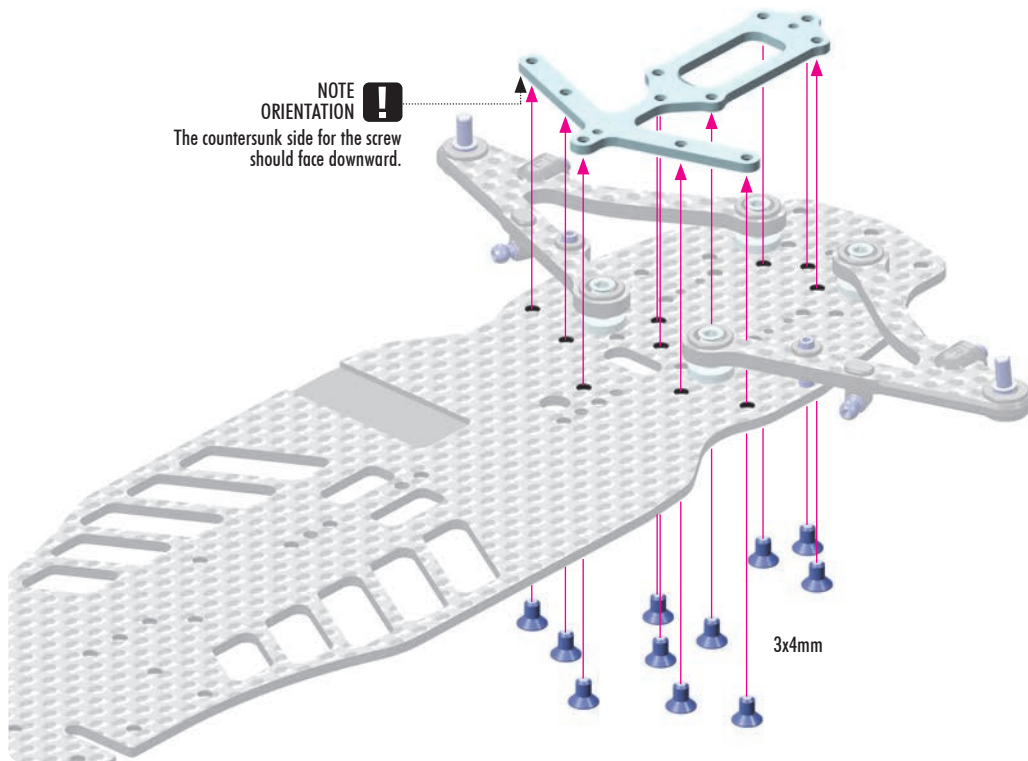

X4F ALU CHASSIS BRACE FLEX ADJUSTMENT POSSIBILITIES

The new feature of X4F'27 is the alu chassis brace which is mounted in the front suspension area and allows great flex adjustment alternatives.

NO BRACE

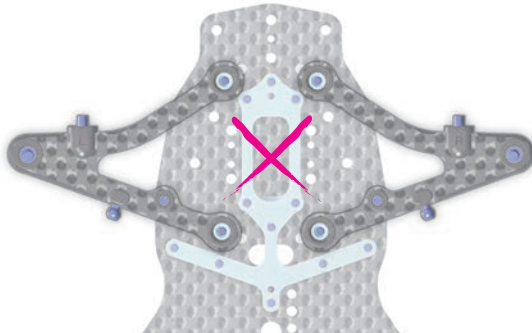

Gives maximum forward traction but less response.
Recommended for medium and large asphalt tracks with low and medium traction conditions.

DIFFERENTIAL AREA SCREWS

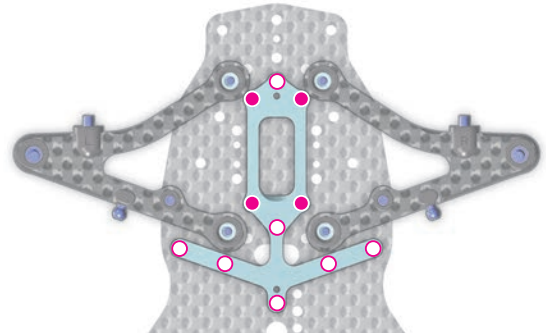

 **INITIAL SETTING**

Gives the best balance between reactivity and forward traction.
Recommended for medium and large carpet tracks in all conditions.

BEHIND ARMS AREA

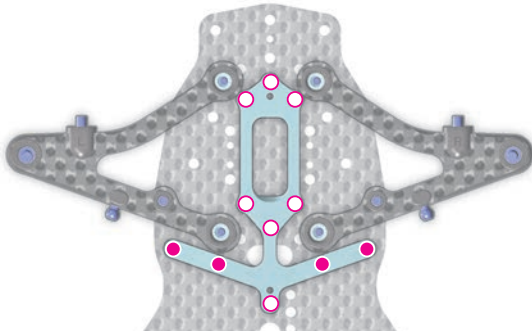

Increases the car's responsiveness but reduces mid-corner steering.
Recommended for small tracks with medium to high traction.

FULL CONNECTED

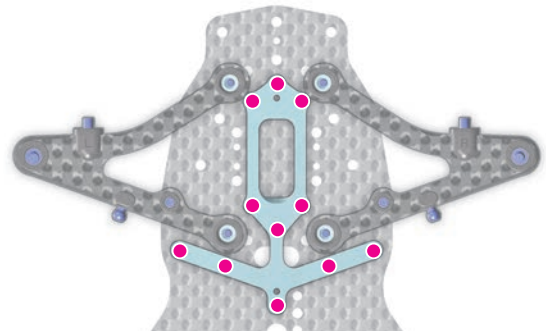

Gives the car the most reactivity but makes it hard to drive and increases the tendency for traction rolling.
Recommended for small tracks.

3. CENTRAL TRANSMISSION

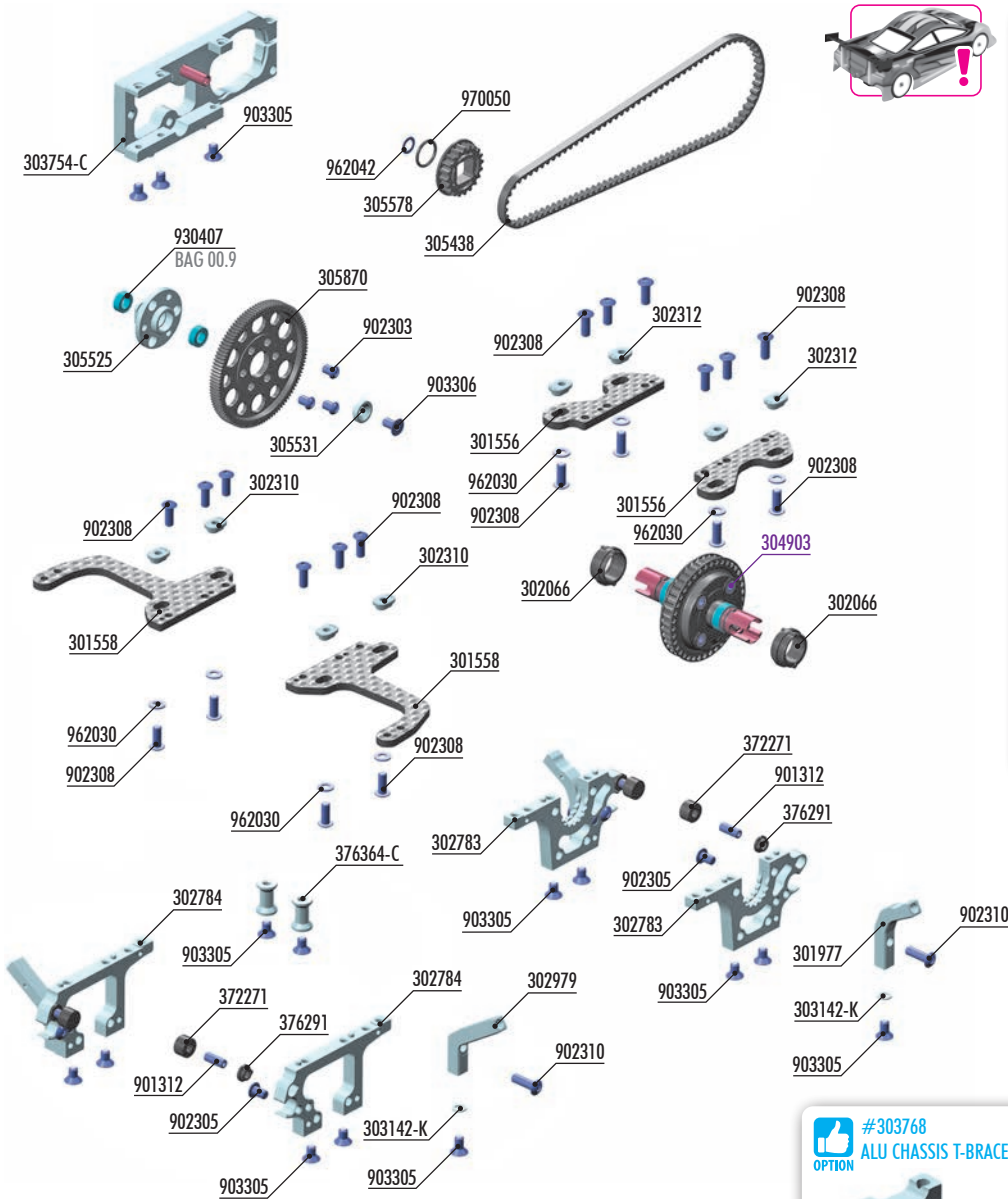

SPUR GEARS 48P			
OPTION	#305772	72T / 48P	OPTION
	#305776	76T / 48P	OPTION
	#305778	78T / 48P	OPTION
	#305779	79T / 48P	OPTION
	#305781	81T / 48P	OPTION
	#305784	84T / 48P	OPTION
	#305784-0	84T / 48P	OPTION

OFFSET SPUR GEARS 64P			
	#305860	90T / 64P	OPTION
	#305862	92T / 64P	OPTION
	#305866	96T / 64P	OPTION
	#305866-0	96T / 64P	OPTION
	#305869	99T / 64P	OPTION
	#305870	100T / 64P	INCLUDED
	#305870-0	100T / 64P	OPTION
	#305874	104T / 64P	OPTION
	#305876	106T / 64P	OPTION
	#305878	108T / 64P	OPTION
	#305880	110T / 64P	OPTION
	#305880-0	110T / 64P	OPTION
	#305882	112T / 64P	OPTION
	#305884	114T / 64P	OPTION



ALU CASTER BUSHINGS			
OPTION	#302310	FRONT 3° / REAR 5.5° or 0.5°	1 Dot INCLUDED
	#302311	FRONT 4° / REAR 4.5° or 1.5°	2 Dots OPTION
	#302312	FRONT 5° / REAR 3.5° or 2.5°	3 Dots INCLUDED



- | | | | |
|----------|---|----------|---|
| 301556 | X4 UNIVERSAL CARBON UPPER CLAMP FOR UNI BULKHEADS (2) | 376364-C | ALU MOUNT 10.8mm - BLACK (2) |
| 301558 | X4F REAR CARBON UPPER CLAMP FOR UNI BULKHEADS (2) | 901302 | HEX SCREW SB M3x2.5 (10) |
| 301977 | X4F ALU SHOCK HOLDER FRONT FIXED FOR UNI BULKHEADS (2) | 901312 | HEX SCREW SB M3x12 (10) |
| 302066 | COMPOSITE ADJUSTMENT BALL-BEARING HUB FOR UNI BULKHEADS (4) | 902303 | HEX SCREW SH M3x4 SMALL HEAD - STAINLESS (10) |
| 302310 | ALU CASTER BUSHING FRONT 3° / REAR 0.5°/5.5° - 1 DOT (4) | 902305 | HEX SCREW SH M3x5 (10) |
| 302312 | ALU CASTER BUSHING FRONT 5° / REAR 2.5°/3.5° - 3 DOTS (4) | 902308 | HEX SCREW SH M3x8 (10) |
| 302783 | X4F ALU FRONT BULKHEAD - SWISS 7075 T6 | 902310 | HEX SCREW SH M3x10 (10) |
| 302784 | X4F ALU REAR BULKHEAD - SWISS 7075 T6 | 903305 | HEX SCREW SFH M3x5 (10) |
| 302979 | X4F ALU SHOCK HOLDER REAR FIXED - LOWER - SWISS 7075 T6 (2) | 903306 | HEX SCREW SFH M3x6 (10) |
| 303142-K | ALU SHIM 3x5x0.5mm - BLACK (10) | 930407 | BALL-BEARING 4x7x2.5 STEEL SEALED - OIL (2) |
| 303754-C | X4F ALU MOTOR MOUNT - SWISS 7075 T6 | 962030 | WASHER S 3x6x0.3 (10) |
| 305438 | HIGH-PERFORMANCE DRIVE BELT 3 x 291mm | 962042 | WASHER S 4x6x0.1 (10) |
| 305525 | X4F ALU SOLID LAYSHAFT & BEARINGS | 970050 | O-RING 5x1 (10) |
| 305531 | X4F ALU SOLID LAYSHAFT WASHER FOR BATTERY BACKSTOP | 304903 | X4 BB GEAR DIFFERENTIAL FOR UNI BULKHEADS - SET |
| 305578 | FIXED PULLEY FOR LAYSHAFT WITH BEARINGS 20T (2) | | |
| 305870 | OFFSET SPUR GEAR 100T / 64P | | |
| 372271 | COMPOSITE STEERING BLOCK BACKSTOP (2) | | |
| 376291 | COMPOSITE M3 SNAP LOCK BUSHING (8) | | |

Numbers in parentheses () refer to quantities when purchased separately.



3. CENTRAL TRANSMISSION

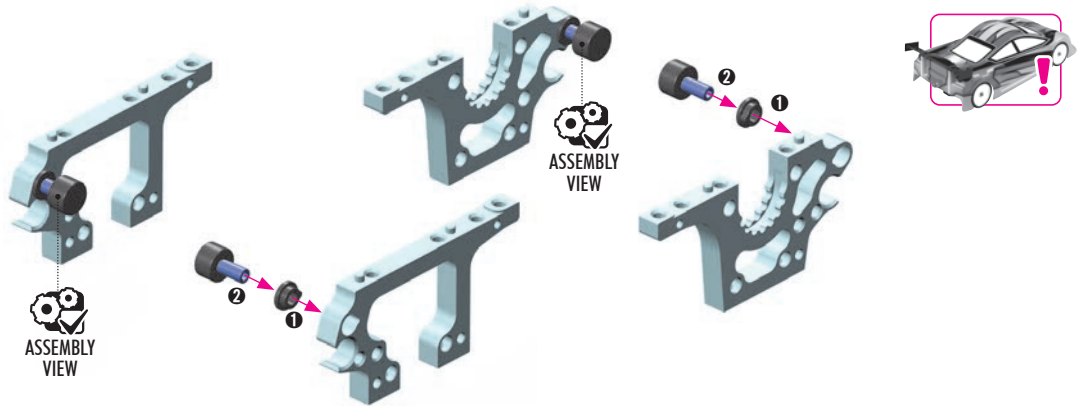
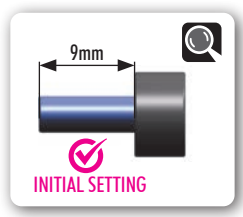
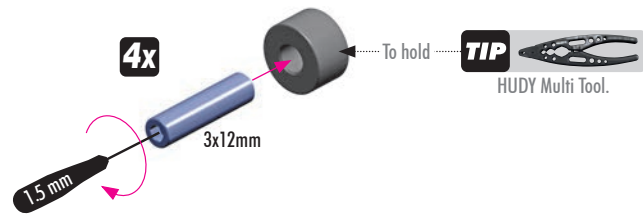

BULKHEAD FLEX ADJUSTMENT

A new feature of the X4F'27 is the bulkhead flex adjustment, which allows the flex of the bulkheads under compression to be adjusted. This feature provides a wide range of flex settings for different track conditions.

FRONT SUSPENSION BULKHEADS FLEX ADJUSTMENT REAR

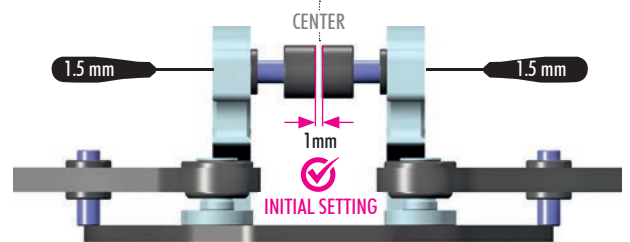
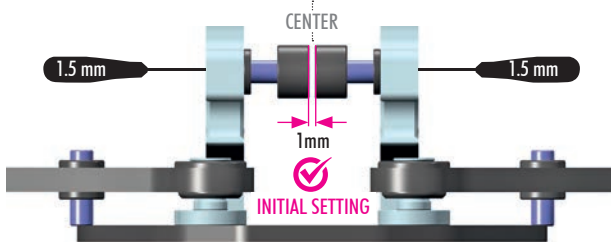

Touching (NO FLEX)

Gives the car the most reactivity but makes it more difficult to drive. Corner speed increases. Recommended for MEDIUM & HIGH-TRACTION conditions and small to medium tracks.

1mm play (LITTLE FLEX)

Provides more forgiving handling with a balance between reactivity and corner-exit steering. Recommended for LOW & MEDIUM-TRACTION conditions and medium to large tracks.

2mm+ play (FULL FLEX)

Easiest to drive and provides maximum stability. Recommended for large tracks with high traction.

Touching (NO FLEX)

Gives the car the most stability and makes it the most predictable to drive. Recommended for all conditions and medium to large tracks.

1mm play (LITTLE FLEX)

Increases rotation of the car, but makes it more difficult to drive. Recommended for MEDIUM & HIGH TRACTION conditions and small to medium tracks.

2mm+ play (FULL FLEX)

Gives the car the most rotation and reduces rear stability but makes it the hardest to drive. Recommended for small, technical tracks with MEDIUM TO HIGH TRACTION.

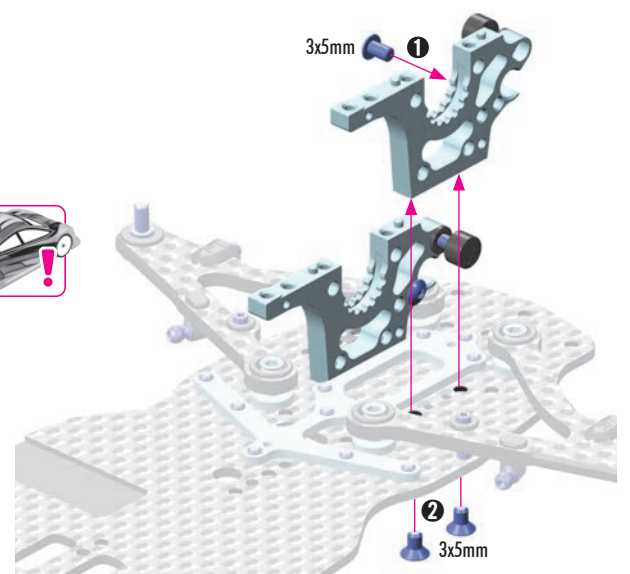
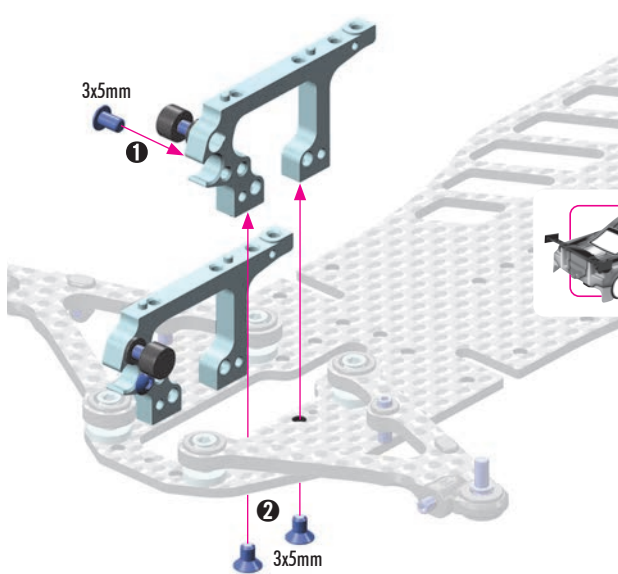

VIDEO TECH TIP



BUILDING THE BULKHEADS

3. CENTRAL TRANSMISSION

FRONT GEAR DIFF

LONGER SHORTER

LEFT RIGHT

LONGER SHORTER

NOTE ORIENTATION
Please see page 17 / step 2 for

#302067-K
ALU ADJUSTMENT BALL-BEARING HUB (2)

8x 902308 SH M3x8

8x 962030 S 3x6x0.3

! **L=R** All 4 bushings at one end of the car must be installed in the same orientation.

ASSEMBLED VIEW

ASSEMBLED VIEW

Use 1 DOT alu caster bushings in REAR carbon upper clamps.

Use 3 DOTS alu caster bushings in FRONT alu upper clamps.

0.3mm 3x8mm

0.3mm 3x8mm

Never use alu or titanium screws for the eccentric bushings.

Never use alu or titanium screws for the eccentric bushings.

VIDEO TECH TIP

CASTER

OPTION	#	FRONT	REAR	Dots	INCLUDED
	#302310	FRONT 3°	REAR 5.5° or 0.5°	1 Dot	INCLUDED
	#302311	FRONT 4°	REAR 4.5° or 1.5°	2 Dots	OPTION
	#302312	FRONT 5°	REAR 3.5° or 2.5°	3 Dots	INCLUDED

#301557
X4 UNIVERSAL CARBON UPPER CLAMP -1mm (2)

! **CASTER ADJUSTMENT**

FRONT CASTER
For most conditions, 5.0 deg front caster is a good starting point. Decreasing caster increases entry steering but will cause more on-power push.

REAR CASTER
A good starting point for rear caster is 0.5°.

0.5 caster generates more cornerspeed and makes the car easier to drive in long sweepers. Recommended for both carpet and asphalt tracks.

5.5 caster improves rotation and steering, mainly recommended for tight tracks.

IMPORTANT
All 4 bushings at one end of the car must be installed in the same orientation.

REAR CASTER

1 Dot = 0.5° Caster **✓ INITIAL SETTING**

2 Dots = 1.5° Caster

3 Dots = 2.5° Caster

1 Dot = 5.5° Caster

2 Dots = 4.5° Caster

3 Dots = 3.5° Caster

FRONT CASTER

1 Dot = 3.0° Caster

2 Dots = 4.0° Caster

3 Dots = 5.0° Caster **✓ INITIAL SETTING**

3. CENTRAL TRANSMISSION



12x 902308 SH M3x8



VIDEO TECH TIP



UPPER CLAMP FLEX OPTIONS

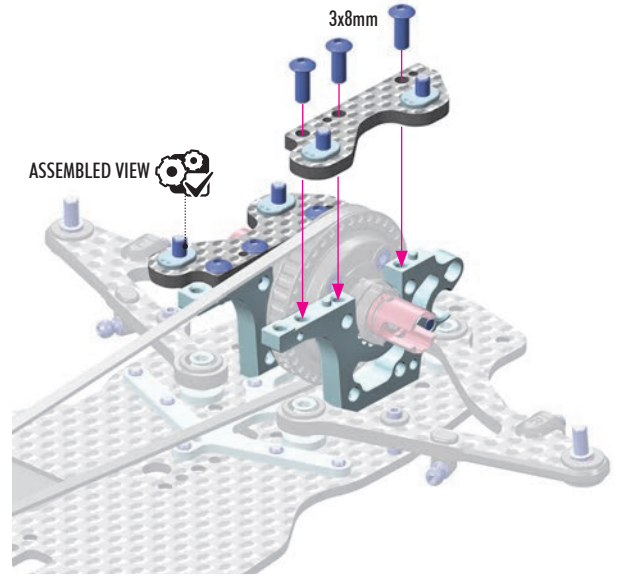
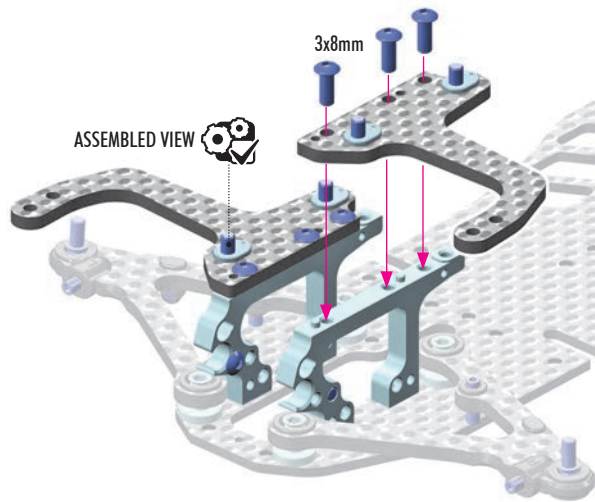

UPPER CLAMP FLEX ADJUSTMENT - 4 DIFFERENT COMBINATIONS

All-new upper clamp mounting alternatives for different flex and handling characteristics. The clamps feature 3 screws which can be used in different combinations.

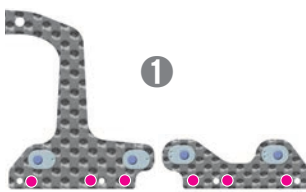

All 3 screws mounted (front and rear)

INITIAL SETTING

Provides most neutral and forgiving handling. Recommended for most conditions, including high traction.

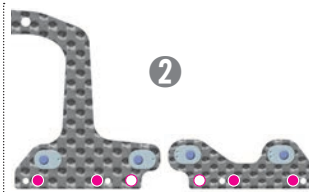

2 most forward screws mounted (in the front)
2 most rearward (in the rear)

Creates the most steering; ideal when maximum mid-corner steering is required. Car is more aggressive and more difficult to driver compared to Setting 1.

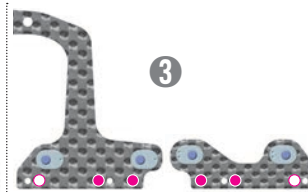

2 most rearward screws mounted (in the front)
2 most forward (in the rear)

Gives similar handling feel as Setting 2.

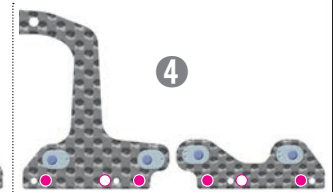

First and the 3rd screw mounted (front and rear)

Handling when removing the center screw is between Setting 1 and 2/3. The additional flex increases mechanical traction. The car will feel more "in the track", but maximum cornering speed is reduced compared to Setting 1.

#301557
OPTION X4 UNIVERSAL CARBON UPPER CLAMP -1mm (2)



The optional upper clamps move the inner pivot 1.0mm closer to the centerline. This position will lengthen the upper arms and reduce camber gain to free up the car. Mid-corner steering improves in long sweepers, and traction rolling is reduced in very high traction conditions. Recommended for large open layouts or high traction surfaces.



VIDEO TECH TIP



DIFF HEIGHT



BELT TENSION ADJUSTABLE



FRONT BELT TENSION ADJUSTMENT

Front diff **UPPER** position - tab in bottom notch - provides **more steering**, but **less front traction**

Front diff **LOWER** position - tab in top notch - provides **more front traction**, but makes the car **push on-power**.

Recommended for **medium-high** traction tracks and technical tracks.

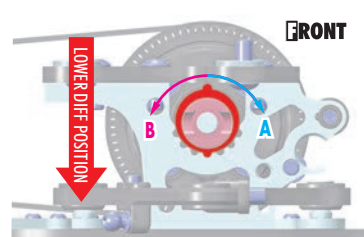
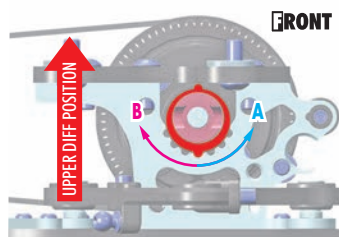

Recommended for **low-traction** tracks.

INITIAL POSITION FOR CARPET/ASPHALT
Place tab in this **BOTTOM NOTCH**

TO LOOSEN REAR BELT: Rotate both front nylon hubs in arrow direction **A**
TO TIGHTEN REAR BELT: Rotate both front nylon hubs in arrow direction **B**

3. CENTRAL TRANSMISSION



1.

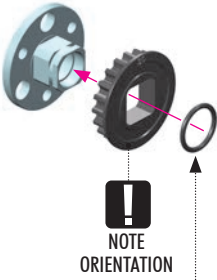

#966081
CH-CLIP 8 (10)
INCLUDED IN THE
LAST AID BAG

Another alternative to secure the pulley on the layshaft is to use the CH-clip which is included in the "Last Aid" Bag. To mount the clip on the layshaft, you have to use special Snap Ring Pliers.



#305578-0
FIXED PULLEY FOR
LAYSHAFT WITH
BEARINGS 20T
GRAPHITE (2)



2. ALTERNATIVE
64P OFFSET SPUR GEAR
INITIAL SETTING

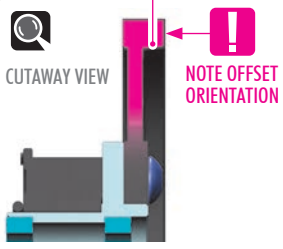
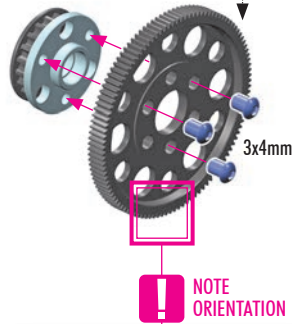

OPTION	OFFSET SPUR GEARS 64P		
#305860	90T	OPTION	
#305862	92T	OPTION	
#305866	96T	OPTION	
#305866-0	96T	OPTION	
#305869	99T	OPTION	
#305870	100T	INCLUDED	
#305870-0	100T	OPTION	
#305874	104T	OPTION	
#305876	106T	OPTION	
#305878	108T	OPTION	
#305880	110T	OPTION	
#305880-0	110T	OPTION	
#305882	112T	OPTION	
#305884	114T	OPTION	

2. ALTERNATIVE
48P SPUR GEAR

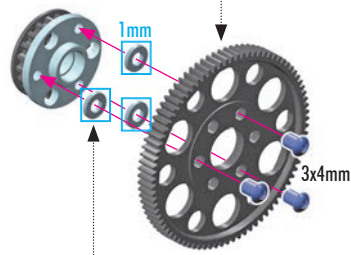

When using XRAY 48P spur gears or aftermarket spur gears without an offset, use the 3x5x1mm shims (#303141 NOT included) between the gear and layshaft to create the necessary clearance from the top deck.

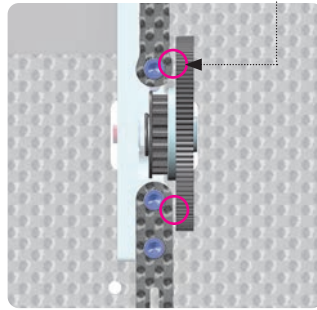

OPTION	SPUR GEARS 48P		
#305772	72T	OPTION	
#305776	76T	OPTION	
#305778	78T	OPTION	
#305779	79T	OPTION	
#305781	81T	OPTION	
#305784	84T	OPTION	
#305784-0	84T	OPTION	

3.

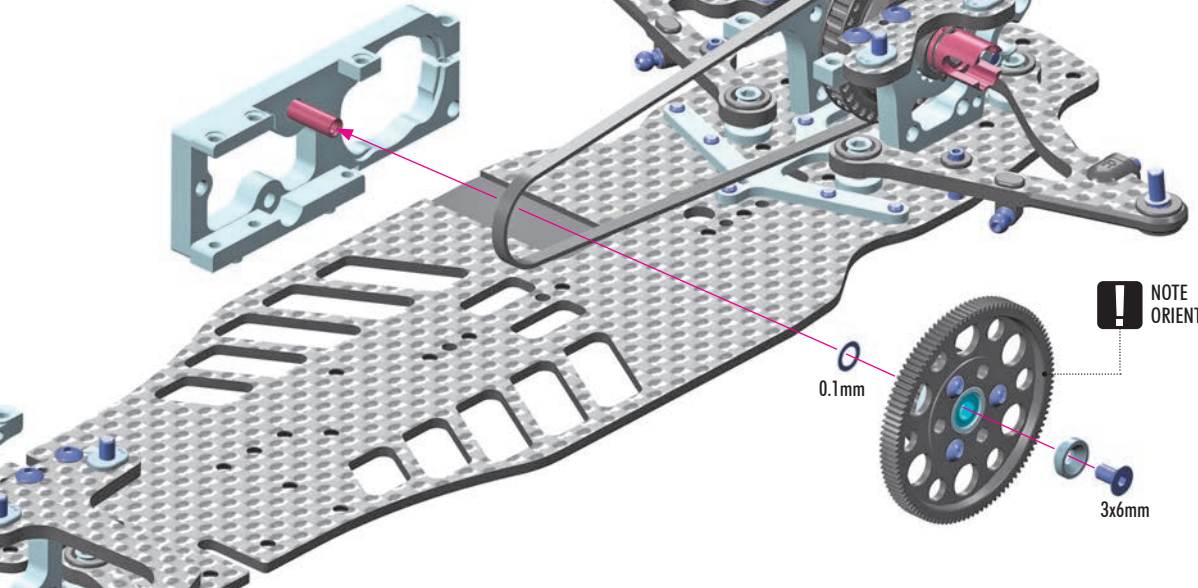
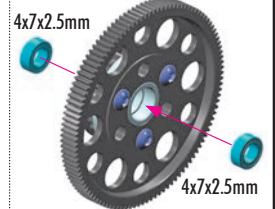

VIDEO TECH TIP



BELT TENSION
ADJUSTMENT

3. CENTRAL TRANSMISSION

2x 903305 SFH M3x5

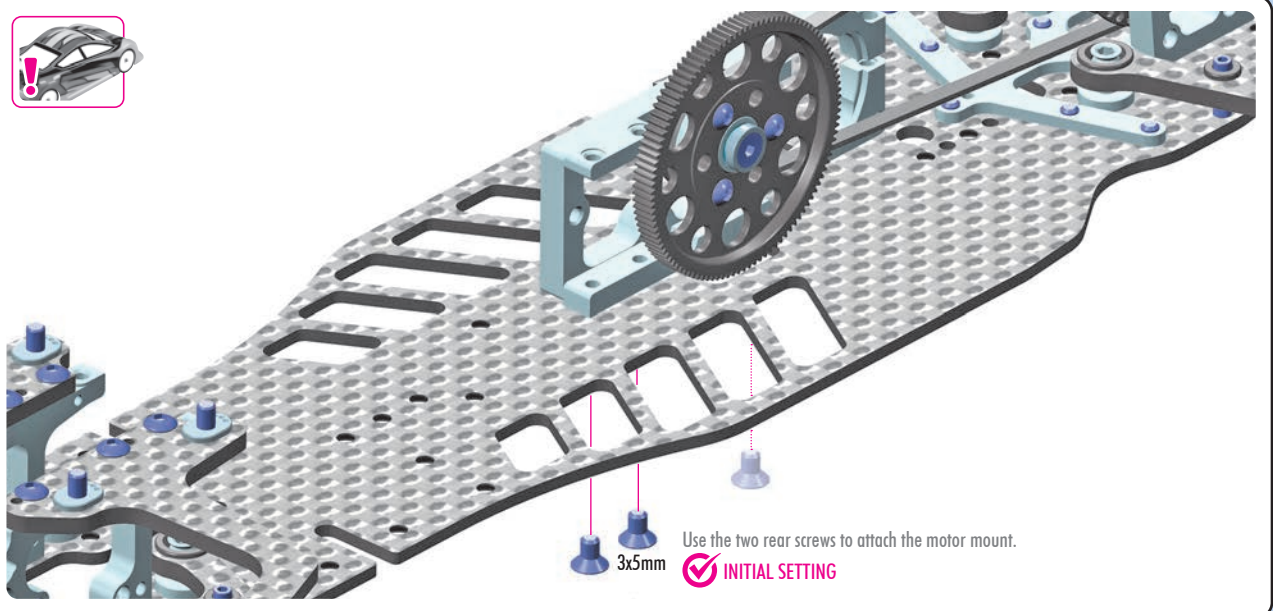

Use the two rear screws to attach the motor mount.
 3x5mm **INITIAL SETTING**

MOTOR MOUNT FLEX ADJUSTMENT



SOFT

Use only the rearmost screw to attach the motor mount as shown below. This allows more central chassis flex and will improve traction, especially on power. Rear traction will improve through the entire corner. This setting is recommended for low to medium traction conditions, both on asphalt and carpet.

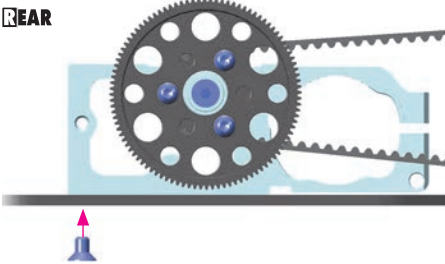

MEDIUM **INITIAL SETTING**

Use the two rear screws to attach the motor mount as shown, and DO NOT install the very front screw. This configuration is a compromise between stability and initial response. The additional rear screw improves stability with a slight reduction in steering.

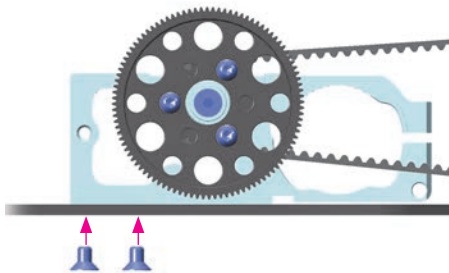

STIFF

Use all three screws to attach the motor mount for maximum stability. Recommended for high traction surfaces.

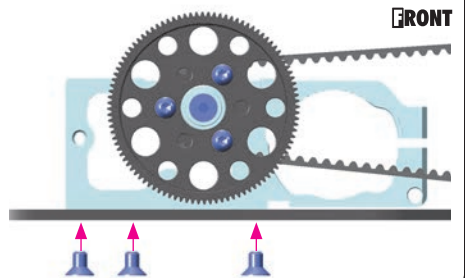

2x 903305 SFH M3x5

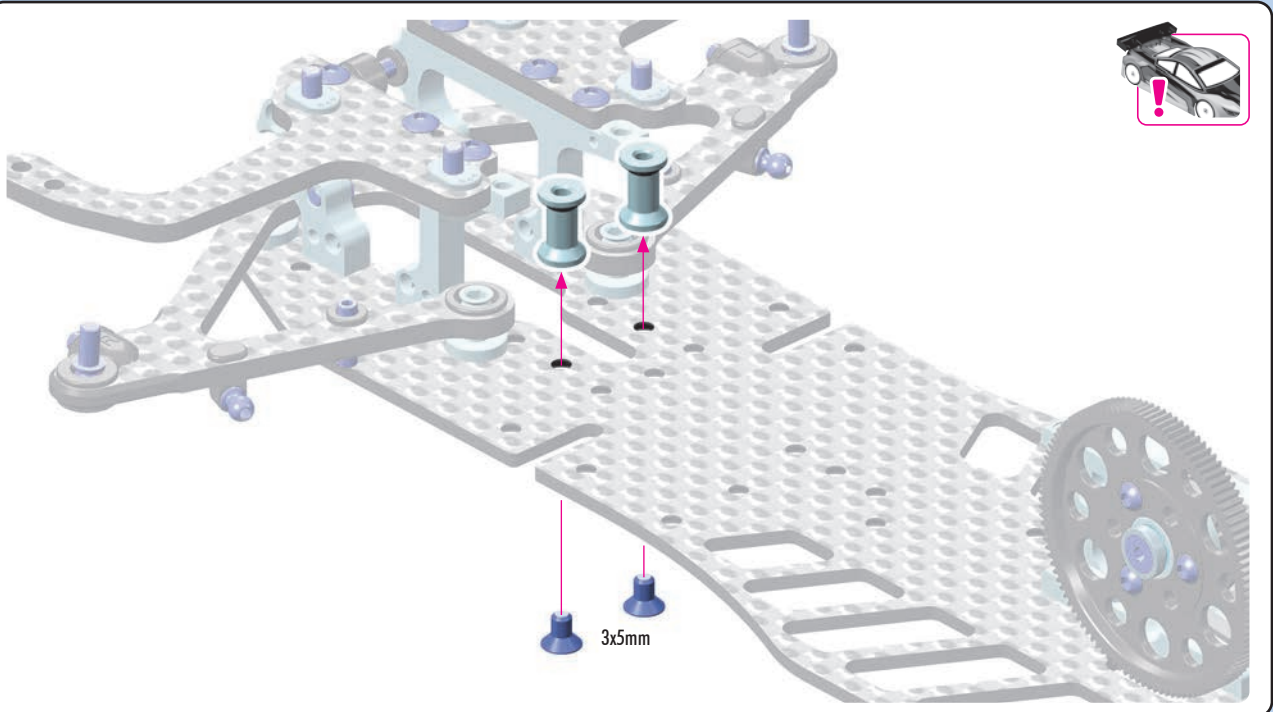

3x5mm

3. CENTRAL TRANSMISSION

- 2x 303121-K SHIM 3x6x0.5
- 3x 903305 SFH M3x5
- 2x 903306 SFH M3x6

OPTION T-BRACE

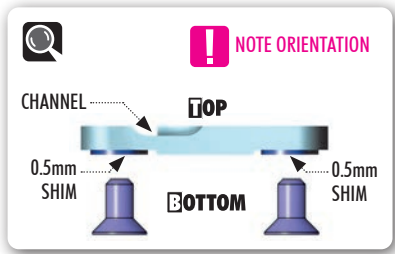
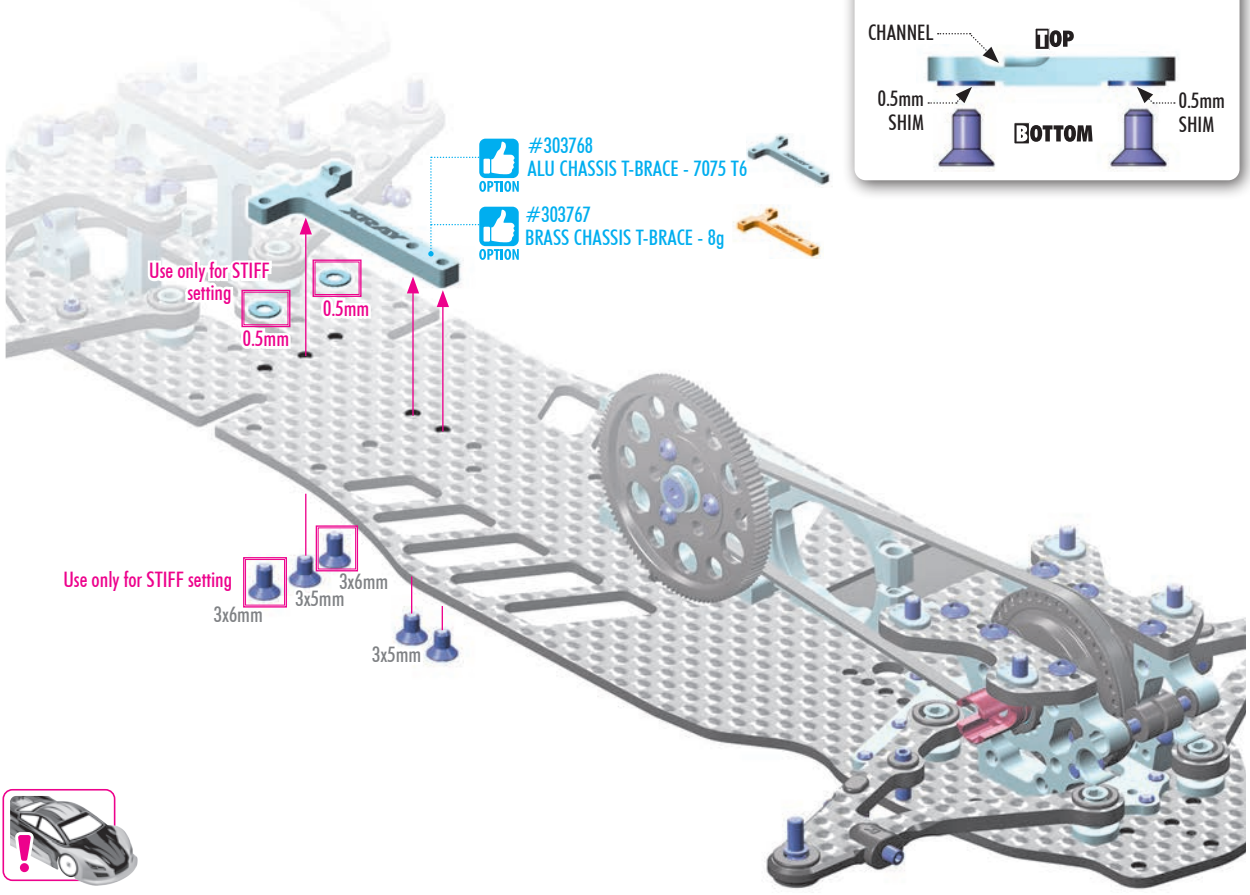

CHASSIS FLEX ADJUSTMENT

The brace provides chassis flex adjustment possibilities depending on which screws are connected.

SOFT - NO BRACE

When the brace is NOT installed, the car will have the most steering and rotation. However, the car will be more difficult to drive as it is less stable. Recommended for medium-high traction conditions and for small, technical tracks with many hairpin corners.

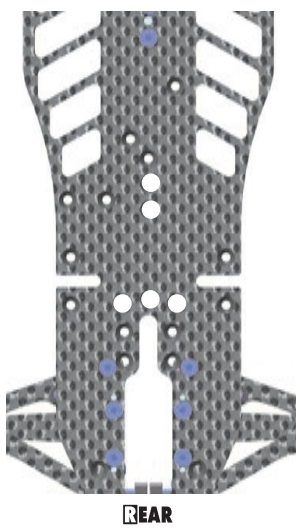

SOFT - MEDIUM

Install the brace using only the 2 forward bottom centerline screws (as shown). This gives improved on-power stability but still offers great off-power steering and rotation. Recommended for medium-high traction conditions and for small, technical tracks with many hairpin corners.

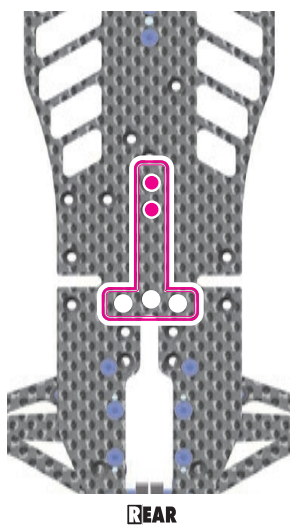

MEDIUM

Install the brace using all 3 bottom centerline screws (as shown). This gives improved on-power stability and traction, but makes the car push more off-power. Recommended for low- or high-traction conditions where stability and traction is needed.

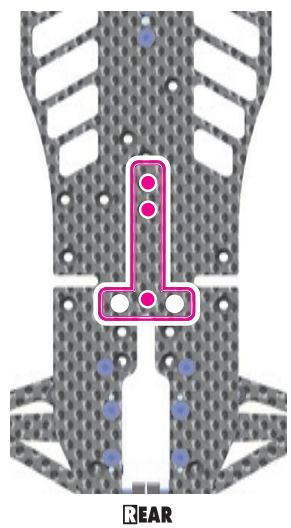

STIFF

In addition to installing all 3 bottom centerline screws, install the 2 side screws using 0.5mm shims between the brace and chassis. This setting gives maximum stability.

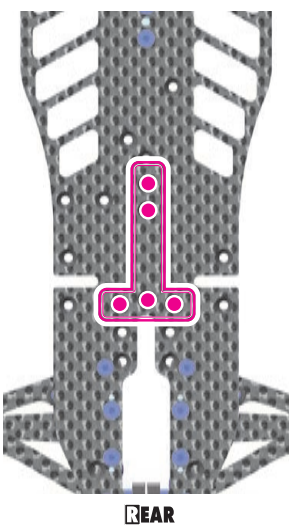

3. CENTRAL TRANSMISSION

REAR SHOCK HOLDERS FLEX ADJUSTMENT

The brace provides chassis flex adjustment possibilities depending on which screws are connected.

FLEX ALTERNATIVE 1. INITIAL SETTING

Attach the shock holder to both the chassis and bulkhead for free yet predictable handling for the easiest control. Recommended as a starting point for all traction levels.

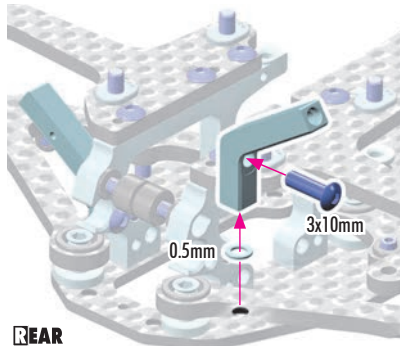

REAR

FLEX ALTERNATIVE 2.

Attach the shock holder to only the chassis for maximum mechanical traction. Recommended for low to medium traction tracks.

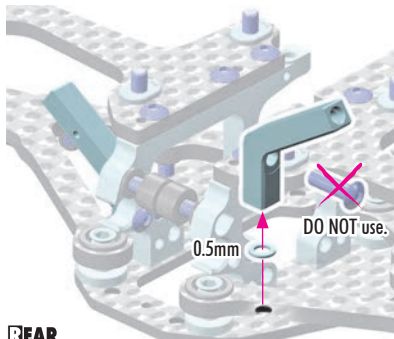

REAR

FLEX ALTERNATIVE 3.

Attach the shock holder to only the bulkhead for more aggressive reaction, but reduced mechanical traction may be more difficult to drive. Recommended for medium to high traction conditions.

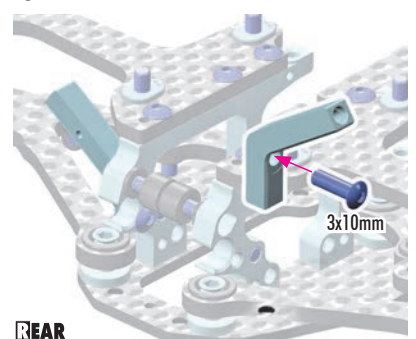

REAR



2x 303142-K SHIM 3x5x0.5

2x 902310 SH M3x10

2x 903305 SFH M3x5

2x 913305 110° SFH M3x5
Used only for 1.5mm alu chassis

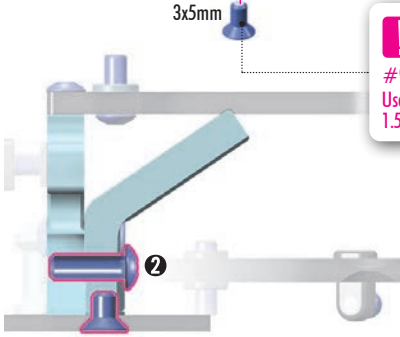

1 » All screws TIGHTEN GENTLY
» Fully TIGHTEN in this order



FRONT SHOCK HOLDERS FLEX ADJUSTMENT

The brace provides chassis flex adjustment possibilities depending on which screws are connected.

FLEX ALTERNATIVE 1. INITIAL SETTING

Attach the shock holder to both the chassis and bulkhead for free yet predictable handling for the easiest control. Recommended as a starting point for all traction levels.

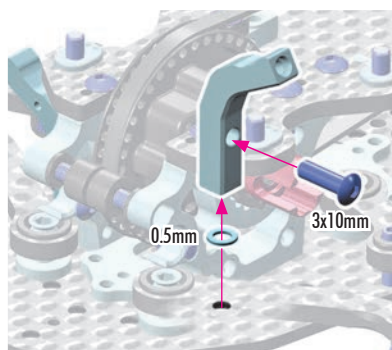

FRONT

FLEX ALTERNATIVE 2.

Attach the shock holder to only the chassis for maximum mechanical traction. Recommended for low to medium traction tracks.

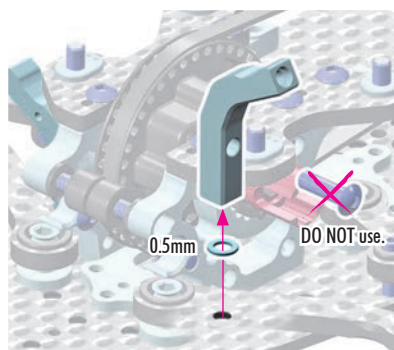

FRONT

FLEX ALTERNATIVE 3.

Attach the shock holder to only the bulkhead for more aggressive reaction, but reduced mechanical traction may be more difficult to drive. Recommended for medium to high traction conditions.

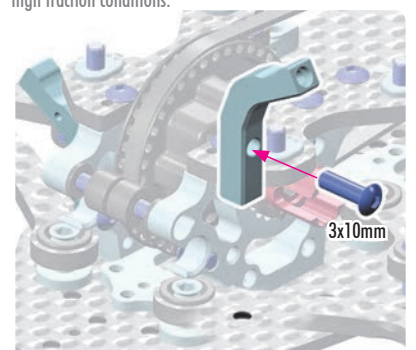

FRONT



2x 303142-K SHIM 3x5x0.5

2x 902310 SH M3x10

2x 903305 SFH M3x5

2x 913305 110° SFH M3x5
Used only for 1.5mm alu chassis

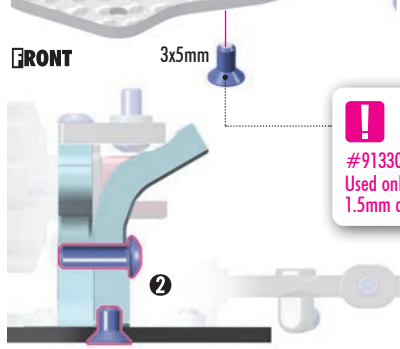

1 » All screws TIGHTEN GENTLY
» Fully TIGHTEN in this order



4. STEERING

#301158-T
X4 TITANIUM TOP DECK
HEX SCREW M3x5.5 (2)

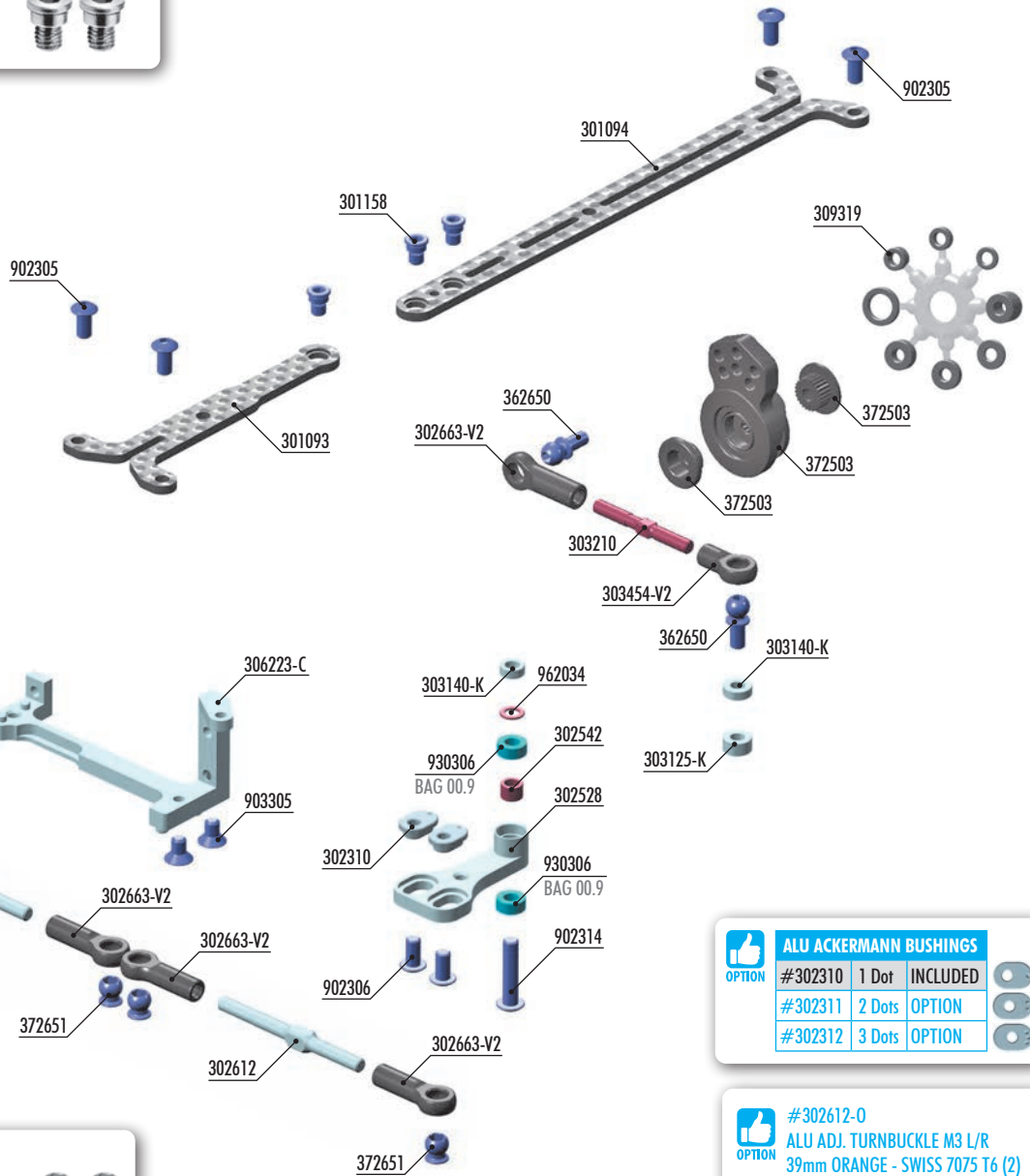

#990102
HU DY TITANIUM PIVOT BALL
D=4.9 / S=3.5 / 3mm HEX (2)



#990006
HU DY TITANIUM BALL STUD
D=4.9 / L=6 / S=3.5 / 2mm HEX (2)



#301095
X4F*27 CARBON UPPER DECK - 2.0mm

Optional one piece top deck increases chassis flex. Suggested for low traction conditions, it may remove some initial steering but generates more overall traction.



#	DESCRIPTION	QUANTITY	STATUS
#302310	1 Dot	1	INCLUDED
#302311	2 Dots	2	OPTION
#302312	3 Dots	3	OPTION

#302612-0
ALU ADJ. TURNBUCKLE M3 L/R
39mm ORANGE - SWISS 7075 T6 (2)



#302610
ADJ. TURNBUCKLE L/R 39mm
HU DY SPRING STEEL (2)



BAG
04

- 301093 X4F CARBON UPPER DECK - SPLIT FRONT - 2.0mm
- 301094 X4F CARBON UPPER DECK - SPLIT REAR - 2.0mm
- 301158 TOP DECK HEX SCREW M3x5.5 - HU DY SPRING STEEL™ (2)
- 302310 ALU CASTER BUSHING FRONT 3° / REAR 0.5°/5.5° - 1 DOT (4)
- 302528 X4F ALU SERVO SAVER ARM - BLACK - SWISS 7075 T6
- 302542 STEEL SHIM 3x4.5x2.1mm (2)
- 302612 ALU ADJ. TURNBUCKLE M3 L/R 39mm - SWISS 7075 T6 (2)
- 302663-V2 COMPOSITE BALL JOINT 4.9mm - OPEN (8)
- 303125-K ALU SHIM 3x6x3.0mm - BLACK (10)
- 303140-K ALU SHIM 3x5x2.0mm - BLACK (10)
- 303210 REAR TURNBUCKLE L/R 26mm - HU DY SPRING STEEL (2)
- 303454-V2 BALL JOINT 4.9mm - OPEN (4)
- 306223-C X4F ALU SERVO MOUNT - BLACK - ONE-PIECE - SWISS 7075 T6

- 309319 UNIVERSAL SET OF PLASTIC SHIMS
- 362650 BALL END 4.9mm WITH THREAD 6mm (2)
- 372503 COMPOSITE SERVO SAVER - X-STIFF - SET - V2
- 372651 PIVOT BALL UNIVERSAL 4.9mm (2)
- 902305 HEX SCREW SH M3x5 (10)
- 902306 HEX SCREW SH M3x6 (10)
- 902314 HEX SCREW SH M3x14 (10)
- 903305 HEX SCREW SFH M3x5 (10)
- 930306 BALL-BEARING 3x6x2.5 STEEL-SEALED - OILED (2)
- 962034 STEEL WASHER S 3x4.7x1 (10)

Numbers in parentheses () refer to quantities when purchased separately.



4. STEERING

2x STEERING LINKS

OPTION #302612-0
ALU ADJ. TURNBUCKLE M3 L/R
39mm ORANGE - SWISS 7075 T6 (2)

OPTION #302610
ADJ. TURNBUCKLE L/R 39mm
HUDY SPRING STEEL (2)

26.1mm

2x L-R

1x SERVO LINK

Adjust servo link to fit your servo.

approx. 13mm

- 2x 902306 SH M3x6
- 1x 902314 SH M3x14
- 1x 302542 SHIM 3x4.5x2.1
- 1x 303140-K SHIM 3x5x2
- 1x 962034 SHIM 3x4.7x1
- 2x 930306 BB 3x6x2.5

INITIAL SETTING
1 DOT ORIENTATION

3x6mm

VIDEO TECH TIP

STEERING SYSTEM

2mm

Silver 1mm

3x6x2.5mm

Black 3x4.5x2.1mm

3x6x2.5mm

3x14mm

ACKERMANN SETTINGS

There are two Ackermann setting alternatives. You can insert the Ackermann inserts in two different orientations which will result in the different Ackermann settings.

Dot oriented in the REAR:

- steering link mounted maximum forward
- less Ackermann

Makes the car more responsive, improves in-corner steering.
This setting equals to X4F'24 Ackermann position.

Dot oriented in the FRONT:

- steering link mounted maximum backward
- more Ackermann

Makes the car easier to drive, improves cornering speed.

Optional 2 Dots and 3 Dots inserts are available as an option for Ackermann setting fine tuning.

OPTION	ALU ACKERMANN BUSHINGS		
#302310	1 Dot	INCLUDED	
#302311	2 Dots	OPTION	
#302312	3 Dots	OPTION	

CHANGE ACKERMANN SETTINGS

To change the Ackermann setting, you can use 2mm screw driver and you can access to the screws from the window in the chassis.

FRONT BOTTOM

STEERING ARM HOLE
Use this hole in the chassis for tightening the steering arm screw.

ACKERMANN SETTING HOLE
Use this hole in the chassis for adjusting the Ackermann setting.

4. STEERING

TIP
Install with HUDY Multi Tool.

2x L=R

NOTE ORIENTATION (Outside)

NOTE ORIENTATION Ball joint open

#990102
HUDY TITANIUM PIVOT BALL
D=4.9 / S=3.5 / 3mm HEX (2)

The composite ball joints must move freely and **CAN NOT** touch each other. In case they are touching, use a hobbyknife to remove material from the ball joints.

CAN NOT TOUCH

1x 303125-K
SHIM 3x6x3

SERVO SAVER

4.9mm BALL
6mm THREAD

3mm

4.9mm BALL
6mm THREAD

Shiny side

Shiny side

Use the adapter that matches the steering servo.

F = 25T H = 24T K = 23T

INITIAL SETTING

VIDEO TECH TIP

STEERING SYSTEM

HUDY ADJUSTABLE CLAMP SERVO HORNS

OPTION

#293414	23T	KO, Sanwa
#293416	25T	Futaba, Savox

ADJUSTABLE 15-19mm HEIGHT

HUDY ALU FIXED SERVO SAVER 1/10 TC & FWD - SET

OPTION #293352

Use the adapter that matches the steering servo.

F = 25T H = 24T K = 23T

ALU SERVO HORNS - OFFSET

#293491	KO, Sanwa - 23T
#293492	Hitec - 24T
#293493	Savox, Futaba - 25T

CLAMP ALU SERVO HORNS - OFFSET

#293401	KO, Sanwa - 23T
#293402	Hitec - 24T
#293403	Savox, Futaba - 25T

CLAMP ALU SERVO HORNS - OFFSET

#293411	KO, Sanwa - 23T
#293412	Hitec - 24T
#293413	Savox, Futaba - 25T

For more in-corner steering and better steering response, aluminum servo horns may be used.

HUDY ALU SERVO HORNS

OPTION

#293497	KO, Sanwa - 23T
#293498	Hitec - 24T
#293499	Savox, Futaba - 25T

HUDY CLAMP ALU SERVO HORNS

#293404	KO, Sanwa - 23T
#293405	Hitec - 24T
#293406	Savox, Futaba - 25T

HUDY ALU SERVO HORNS

OPTION

#293501	KO, Sanwa - 23T
#293502	Hitec - 24T
#293503	Savox, Futaba - 25T

HUDY CLAMP ALU SERVO HORNS

#293407	KO, Sanwa - 23T
#293408	Hitec - 24T
#293409	Savox, Futaba - 25T

IMPORTANT! When an aluminum horn is used, the steering servo saver is **NOT** used. This increases the risk of breaking the servo in serious crashes.



2x 903305
SFH M3x5

! Please set the additional shims aside and save for future steps. They are used in Section 7 Page 46 Step 2 to mount the servo.

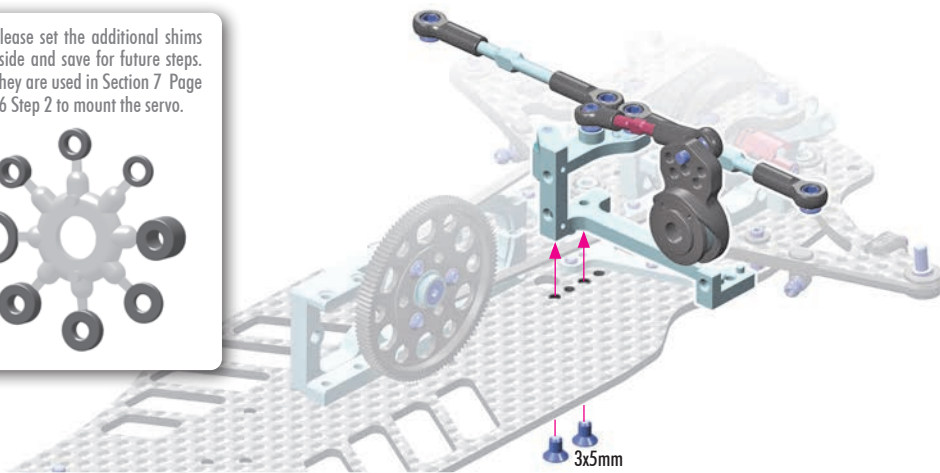

3x 301158
SCREW 3x5.5



4x 902305
SH M3x5

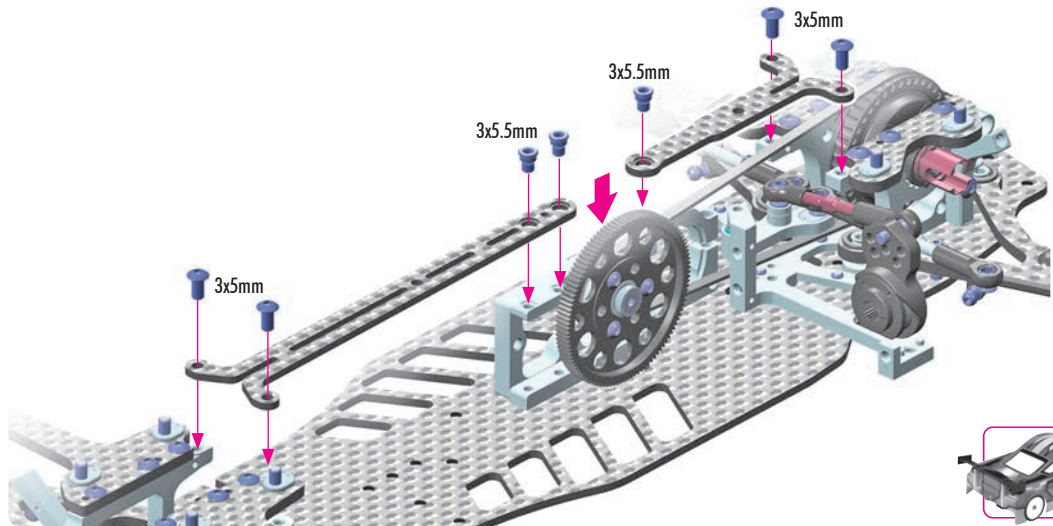

VIDEO TECH TIP



TOP DECK FLEX



TOP DECK (SPLIT) FLEX SETTINGS

The new feature of the split top deck is the flex setting adjustment. There are two different flex setting alternatives.

SOFT

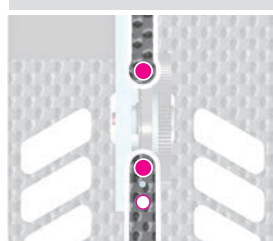

This allows maximum flex and provides maximum steering and rotation. However, the car is less stable on-power.

STIFF

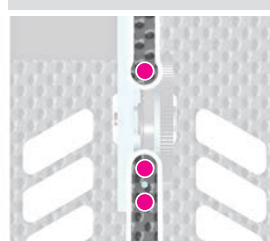

INITIAL SETTING

This setting gives reduced flex in the rear which improves stability and on-power traction.



REAR & FRONT TOP DECK REINFORCEMENT

#902306
OPTION
3x6mm

#306519
OPTION
ALU POST 27.5mm

#903305
OPTION
3x5mm

REAR

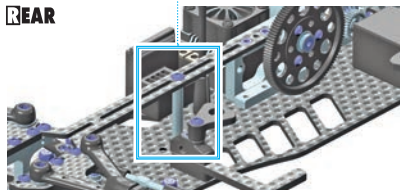

The rear top deck can be connected directly to the chassis using optional: #306519 - Alu Post 27.5mm.

EFFECT:

Increases high-speed stability, reduces off-power rotation, and helps the car to maintain higher corner speed.

#960032
OPTION
M3 - Black (10)

#303127-K
OPTION
3x6x4mm Shim

#902320
OPTION
3x20mm

FRONT

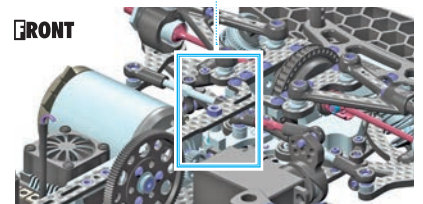

The front top deck can be connected directly to the servo holder. Remove the original M3x14 screw and replace it with optional #902320 - M3x20 screw. The screw will protrude from the servo holder. Place the 3x6x4mm shim over the screw to eliminate the gap between the servo holder and the top deck. Secure the assembly with #960032 - M3 nut on top of the top deck.

EFFECT:

Increases initial steering and front-end bite while reducing chassis flex through the corner.

ASPHALT:

Recommended for medium- to high-traction conditions.

CARPET:

Recommended for low- to medium-traction conditions.

5. FRONT & REAR SUSPENSION

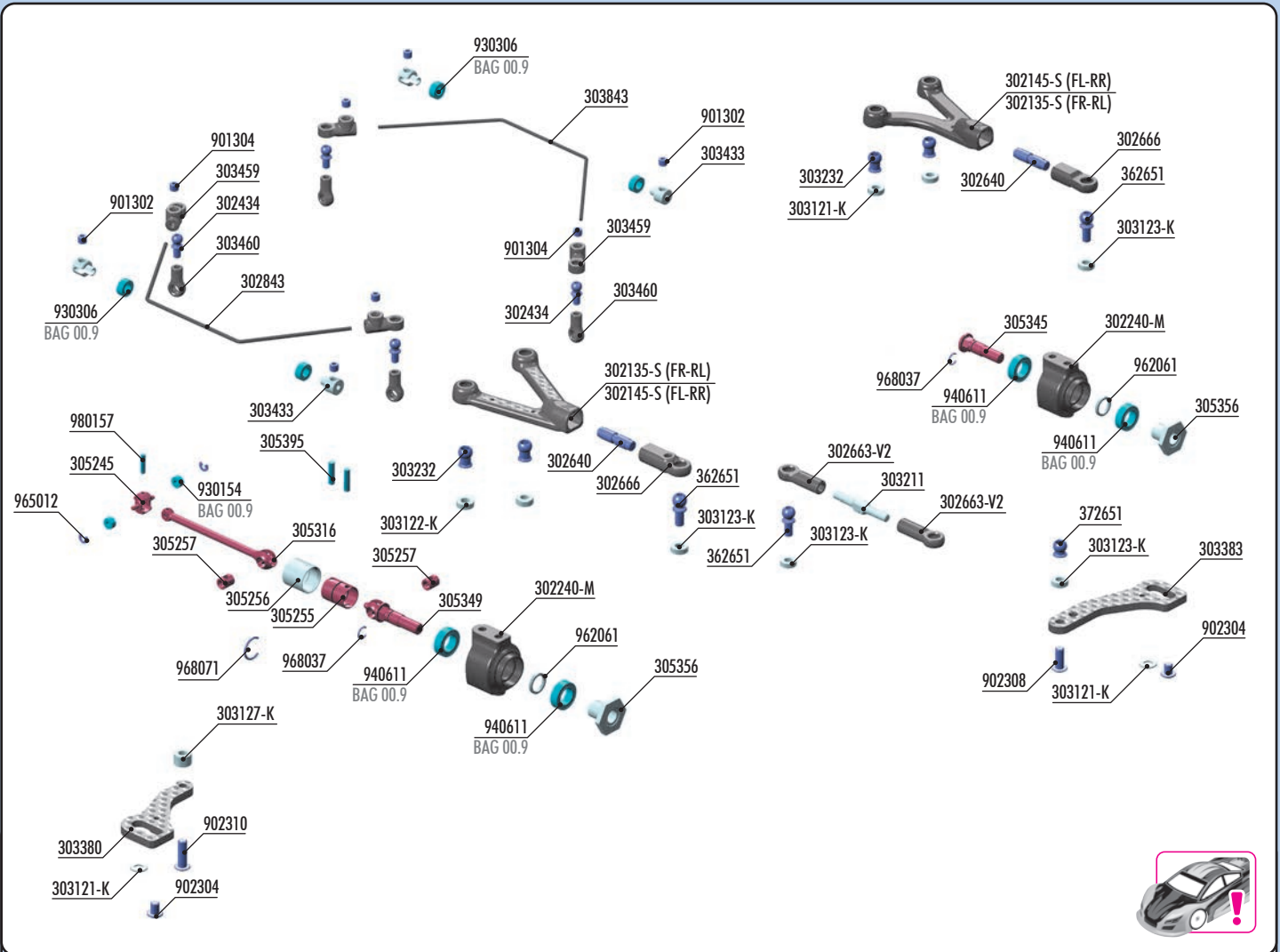

BAG
05

- | | | | |
|-----------|--|--------|--|
| 302135-S | X4 COMPOSITE UPPER ARM - INNER SHOCK POSITION - FR/RL | 305316 | X4 ECS BB DRIVE SHAFT 58mm - HUDY SPRING STEEL™ (2) |
| 302145-S | X4 COMPOSITE UPPER ARM - INNER SHOCK POSITION - FL/RR | 305345 | X4F DRIVE AXLE - HUDY SPRING STEEL™ |
| 302240-M | X4 COMPOSITE STEERING BLOCK - MEDIUM | 305349 | X4 ECS DRIVE AXLE - SPRING CLIP - HUDY SPRING STEEL™ |
| 302434 | ANTI-ROLL BAR STEEL BALL END 3.8mm WITH 2.5x4mm THREAD (2) | 305356 | X4 ALU WHEEL HUB - SPRING CLIP - SWISS 7075 T6 (2) |
| 302640 | ADJUSTABLE CAMBER SCREW 14mm M4 L/R - HUDY SPRING STEEL™ (2) | 305395 | ECS BB SC DRIVE SHAFT PIN 2 x 8.4 (2) |
| 302663-V2 | COMPOSITE BALL JOINT 4.9mm - OPEN (8) | 362651 | BALL END 4.9mm WITH THREAD 8mm (2) |
| 302666 | COMPOSITE BALL JOINT 4.9mm F+R - OPEN (2+2) | 372651 | PIVOT BALL UNIVERSAL 4.9mm (2) |
| 302843 | X4 ANTI-ROLL BAR AAM - ABOVE ARM MOUNT - FRONT 1.3mm | 901302 | HEX SCREW SB M3x2.5 (10) |
| 303121-K | ALU SHIM 3x6x0.5mm - BLACK (10) | 901304 | HEX SCREW SB M3x4 (10) |
| 303122-K | ALU SHIM 3x6x1.0mm - BLACK (10) | 902304 | HEX SCREW SH M3x4 - STAINLESS (10) |
| 303123-K | ALU SHIM 3x6x2.0mm - BLACK (10) | 902308 | HEX SCREW SH M3x8 (10) |
| 303127-K | ALU SHIM 3x6x4.0mm - BLACK (10) | 902310 | HEX SCREW SH M3x10 (10) |
| 303211 | ALU ADJUSTABLE TURNBUCKLE L/R 30mm - SWISS 7075 T6 (2) | 930154 | BALL-BEARING 1.5x4x2 STEEL-SEALED - OIL (4) |
| 303232 | X4 UPPER ARM BALL UNIVERSAL 4.9mm - HUDY SPRING STEEL™ (2) | 930306 | BALL-BEARING 3x6x2.5 STEEL-SEALED - OIL (2) |
| 303380 | X4 CARBON FRONT STEERING PLATE (L+R) | 940611 | BALL-BEARING 6x10x3 RUBBER SEALED - OIL (2) |
| 303383 | X4F CARBON REAR ARS PLATE (L+R) | 962061 | WASHER S 6x7.5x1.0 (10) |
| 303433 | ALU ANTI-ROLL BAR BUSHING ø1.7mm - 6mm (2) | 965012 | E-CLIP 1.2 (10) |
| 303459 | COMPOSITE ANTI-ROLL BAR ø1.6mm BALL JOINT 3.9mm (4) | 968037 | C-CLIP 3.7 (10) |
| 303460 | COMPOSITE ANTI-ROLL BAR BALL JOINT 3.9mm - LONG (4) | 968071 | C-CLIP 7.1 (10) |
| 303843 | X4 ANTI-ROLL BAR AAM - ABOVE ARM MOUNT - REAR 1.3mm | 980157 | PIN 1.5x7.3 (10) |
| 305245 | ECS BB DRIVE SHAFT ADAPTER - HUDY SPRING STEEL™ (2) | | |
| 305255 | ECS BB SC DRIVE SHAFT CASE - HUDY SPRING STEEL™ | | |
| 305256 | ECS BB SC ALU DRIVE SHAFT SLEEVE - SWISS 7075 T6 | | |
| 305257 | ECS BB SC DRIVE SHAFT COUPLING - HUDY SPRING STEEL™ | | |
| 305306 | X4 ECS BB DRIVE SHAFT 58mm - HUDY SPRING STEEL™ - SET | | |

Numbers in parentheses () refer to quantities when purchased separately.

BAG
05.1

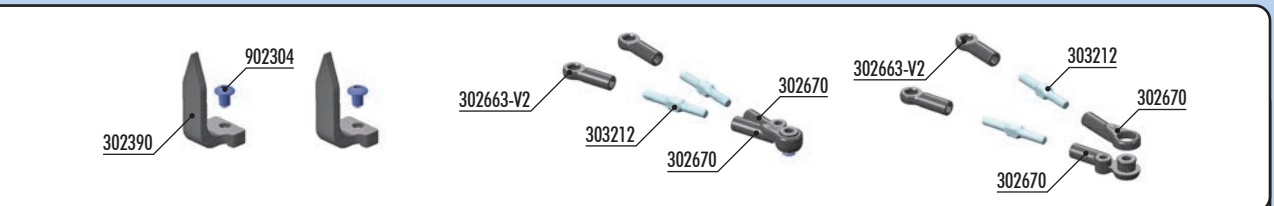

- | | | | |
|-----------|--|--------|------------------------------------|
| 302390 | X4 COMPOSITE CASTER GAUGE (2) | 902304 | HEX SCREW SH M3x4 - STAINLESS (10) |
| 302663-V2 | COMPOSITE BALL JOINT 4.9mm - OPEN (8) | | |
| 302670 | COMPOSITE UPPER ARM LINKS (1+1+1+1) | | |
| 303212 | ALU ADJ. TURNBUCKLE L/R 26MM - SWISS 7075 T6 (2) | | |

5. FRONT & REAR SUSPENSION



4x 305395
P 2x8.4



2x 968037
C 3.7



2x 968071
C 7.1

2x FRONT TRANSMISSION - ECS DRIVE SHAFT

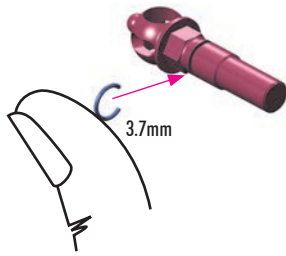

Insert the clip into the groove on the axle. The clip should fit smoothly without extra force and should NOT require pliers. Make sure the clip will rotate after installation.



2x

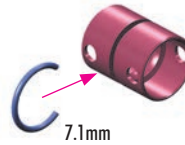

2x

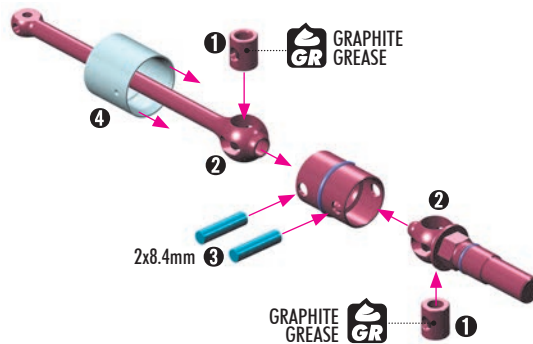

OPTION

FRONT ECS DRIVE SHAFTS

OPTION	Part Number	Length	Material	Status
	#305306	58mm	BB ECS	INCLUDED
	#305307	59mm	BB ECS	OPTION

GRAPHITE GREASE

GRAPHITE GREASE



VIDEO TECH TIP



DRIVE SHAFTS

2x

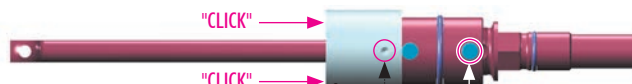

NOTE ORIENTATION

#305307

Longer 59mm front drive shafts provide more stability but reduce steering. Recommended for high traction carpet.

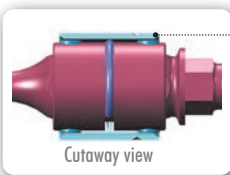

Cutaway view

2x

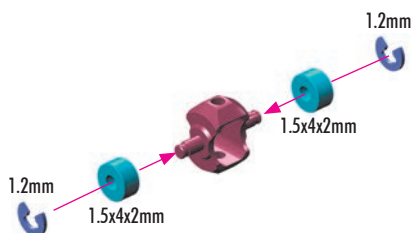

TIP DISASSEMBLY OF ECS DRIVE SHAFT

To disassemble the alu drive shaft sleeve from the drive shaft, hold the sleeve firmly with a HUDY Multi-Tool, and lightly push the drive shaft down against a flat surface.



2x

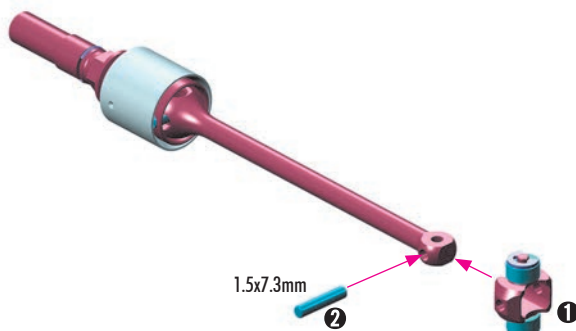

2x 980157
P 1.5x7.3

5. FRONT & REAR SUSPENSION



4x 940611
BB 6x10x3



2x 962061
S 6x7.5x1



2x 968037
C 3.7



VIDEO TECH TIP



FRONT & REAR
UPRIGHTS

2x REAR TRANSMISSION

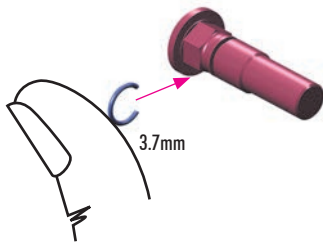

Insert the clip into the groove on the axle. The clip should fit smoothly without extra force and should NOT require pliers. Make sure the clip will rotate after installation.



STEERING BLOCKS

OPTION	#	MATERIAL	INCLUDED
	#302240-M	MEDIUM	INCLUDED
	#302240-H	HARD	OPTION
	#302240-G	GRAPHITE	OPTION
	#302242	ALU Light	OPTION



MEDIUM hubs generate the maximum amount of side traction, which is the best starting point for most conditions.

HARD hubs' additional stiffness is recommended for low to medium traction conditions for balanced handling with good traction and cornering speed.

GRAPHITE hubs are recommended for high to very high traction conditions to help improve rotation and cornering speed.

ALU hubs are recommended for high traction surfaces to improve rotation and free up the car, but they will decrease traction. ALU hubs also improve durability in serious crashes.



OFFSET WHEEL SHIMS

OPTION	#	THICKNESS	INCLUDED
	#305380	0.75mm	OPTION
	#305382	0.5mm	OPTION
	#305381	1.0mm	OPTION



To adjust the width of the car, optional wheel shims can be quickly added or removed.



#305359 ALU WHEEL HUB +0.5mm

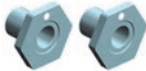

The wider wheel hubs free up the car and improve cornering speed in high traction conditions.



#305354 ALU WHEEL HUB -0.5mm



For very low traction conditions, the narrower wheel hubs can generate more traction and steering but will make the car nervous and decrease cornering speed.

Left UPRIGHT = Right UPRIGHT

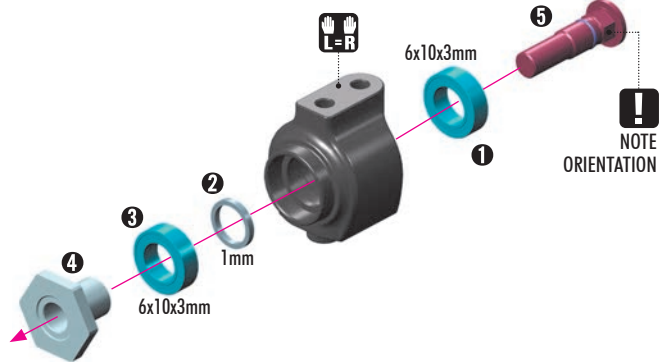

NOTE
ORIENTATION

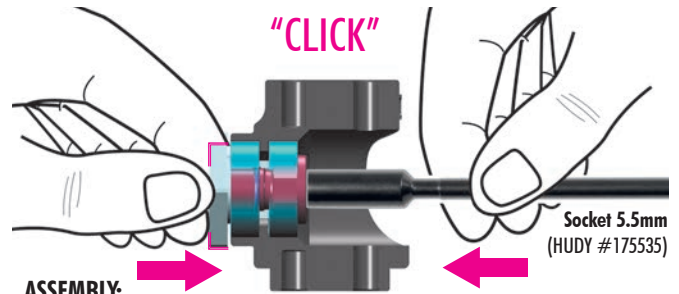

ASSEMBLY:

When installing the wheel hub on the drive axle, make sure the inside groove in the hub seats over the clip on the axle.

To confirm proper installation there should be a 'click' noise when the clip engages the inner groove in the wheel hub. There should be slight axial play once fully seated.

DISASSEMBLY:

To remove the wheel hub from the axle, push the end of the axle back through the wheel hub to separate the wheel hub from the inner clip.

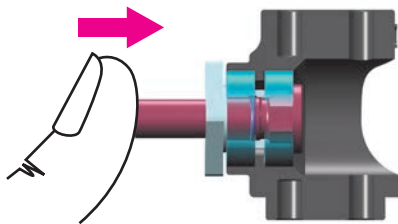

CUTAWAY VIEW

2x REAR TRANSMISSION

NOTE
ORIENTATION

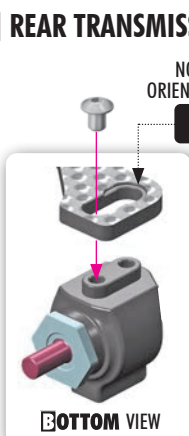

BOTTOM VIEW

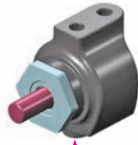

3x4mm
Silver

There are two ARS link mounting alternatives.
For more information see page 35/step 1

INITIAL SETTING

3x8mm

Thread screw into carbon plate.
The screw will stay secure and will not fall out.

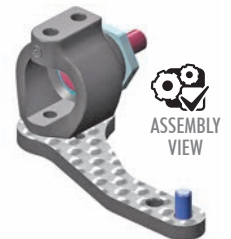

ASSEMBLY
VIEW

5. FRONT & REAR SUSPENSION

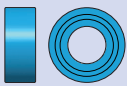

4x 940611
BB 6x10x3



2x 962061
S 6x7.5x1

2x FRONT TRANSMISSION



OFFSET WHEEL SHIMS

#305380	0.75mm	OPTION
#305382	0.5mm	OPTION
#305381	1.0mm	OPTION



To adjust the width of the car, optional wheel shims can be quickly added or removed.

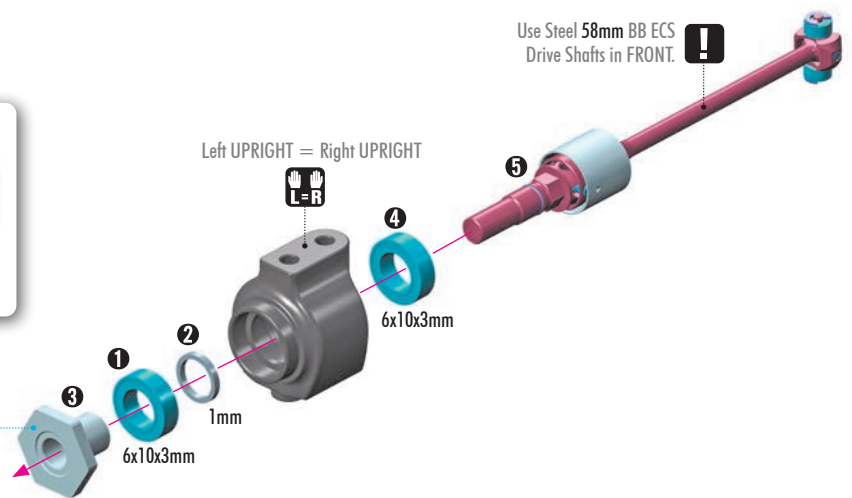

STEERING BLOCKS

#302240-M	MEDIUM	INCLUDED
#302240-H	HARD	OPTION
#302240-G	GRAPHITE	OPTION
#302242	ALU Light	OPTION



MEDIUM hubs generate the maximum amount of side traction, which is the best starting point for most conditions.

HARD hubs' additional stiffness is recommended for low to medium traction conditions for balanced handling with good traction and cornering speed.

GRAPHITE hubs are recommended for high to very high traction conditions to help improve rotation and cornering speed.

ALU hubs are recommended for high traction surfaces to improve rotation and free up the car, but they will decrease traction. Alu hubs also improve durability in serious crashes.



#305359
ALU WHEEL HUB +0.5mm



The wider wheel hubs free up the car and improve cornering speed in high traction conditions.



#305354
ALU WHEEL HUB -0.5mm



For very low traction conditions, the narrower wheel hubs can generate more traction and steering but will make the car nervous and decrease cornering speed.

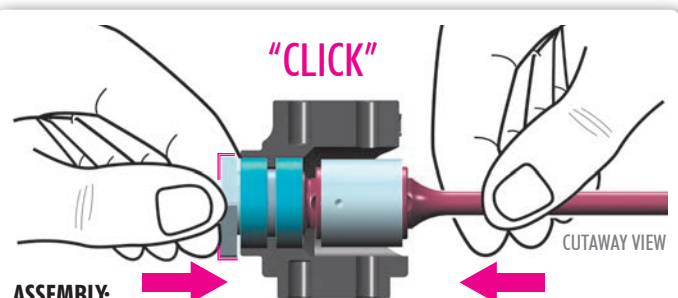

ASSEMBLY:

When installing the wheel hub on the drive axle, make sure the inside groove in the hub seats over the clip on the axle.

To confirm proper installation there should be a 'click' noise when the clip engages the inner groove in the wheel hub. There should be slight axial play once fully seated.

DISASSEMBLY:

To remove the wheel hub from the axle, push the end of the axle back through the wheel hub to separate the wheel hub from the inner clip.

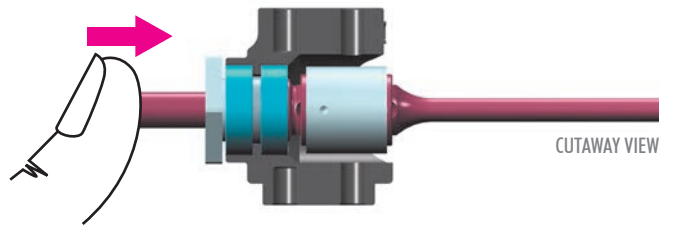

2x FRONT TRANSMISSION



2x 902304
SH M3x4



2x 902310
SH M3x10

Thread screw into carbon plate. The screw will stay secure and will not fall out.



NOTE ORIENTATION

ASSEMBLED VIEW

BOTTOM VIEW

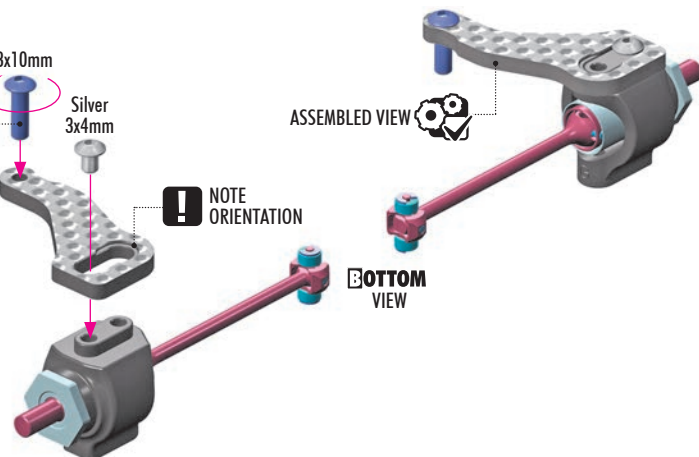

5. FRONT & REAR SUSPENSION

2x 303121-K SHIM 3x6x0.5
ROLL-CENTER

VIDEO TECH TIP

2x REAR SUSPENSION

ASSEMBLY VIEW

0.5mm

INITIAL SETTING

Raising the rear axle height will improve rotation and off-power steering. Recommended for medium to high traction asphalt surfaces. Minimum shim thickness is 0.5mm; DO NOT use thinner.

2x 303121-K SHIM 3x6x0.5

2x FRONT SUSPENSION

ASSEMBLY VIEW

Apply graphite grease to the bearings

0.5mm

Raising the front axle height will free up the front, reduce front traction, and make the car more forgiving to drive. Higher front axle also helps to avoid traction rolling in higher traction conditions. Minimum shim thickness is 0.5mm; DO NOT use thinner.

5. FRONT & REAR SUSPENSION

This kit includes two upper arm **ALTERNATIVES**. The traditional **CFF™ UPPER ARM** and **UPPER ARM LINKS**. Please read the full descriptions before selecting the best alternative.

UPPER ARMS CFF™ ALTERNATIVE

CFF™ Upper Arms are suggested for most conditions as they provide neutral handling and require minimal set-up adjustments between runs.

INITIAL SETTING

VIDEO TECH TIP

CAMBER & UPPER ARMS

FRONT

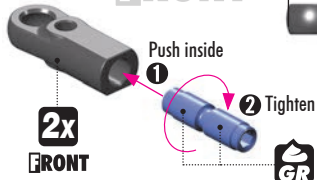

REAR

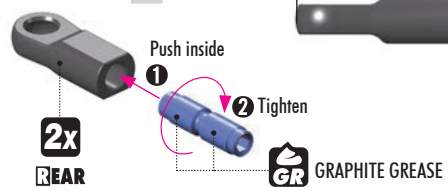
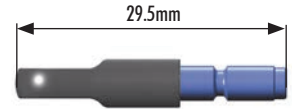

! BOTTOM NOTE ORIENTATION

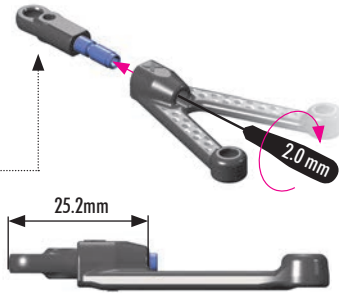
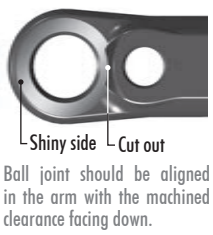

! BOTTOM NOTE ORIENTATION

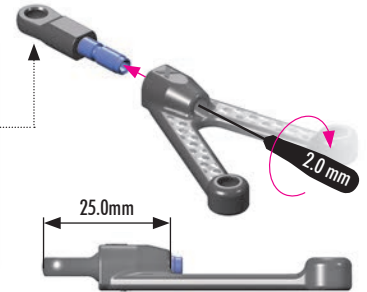
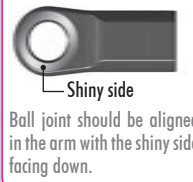

#302640-T
X4 ADJUSTABLE CAMBER SCREW 14mm M4 L/R - TITANIUM (2)
OPTION

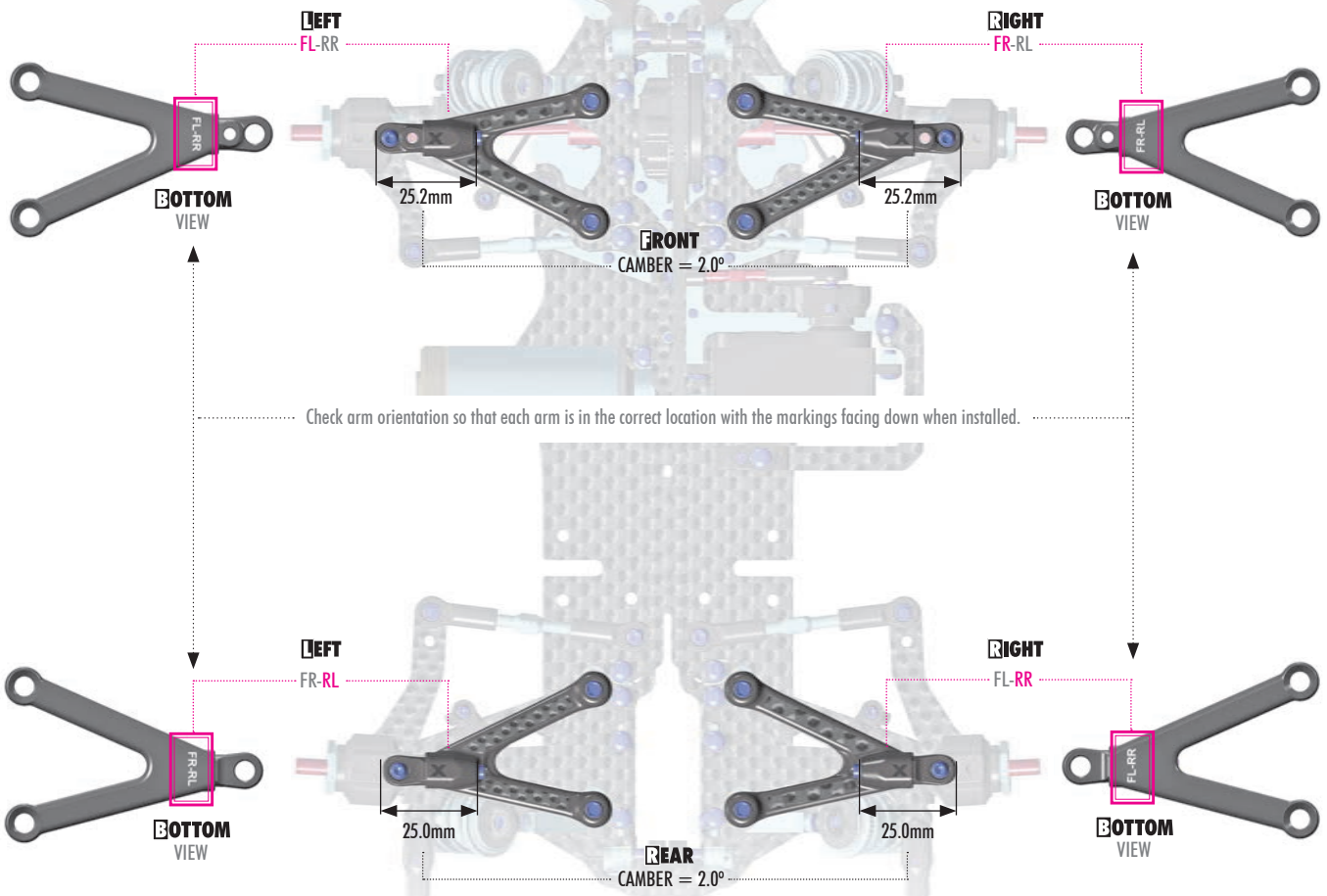

5. FRONT & REAR SUSPENSION

- 4x 303121-K SHIM 3x6x0.5
- 2x 303123-K SHIM 3x6x2

VIDEO TECH TIP

ROLL-CENTER

UPPER ARMS CFF™ ALTERNATIVE REAR SUSPENSION

INITIAL SETTING

NOTE ORIENTATION !

ASSEMBLY VIEW

FL-RR

FR-RL

0.5mm

0.5mm

8mm Thread

2.0mm

TIP Install with HUDY Multi Tool.

Rear upper arm location affects the rear roll-center and camber gain. Raising the arm with thicker shims on the carbon upper clamp will lower the rear roll-center and decrease camber gain. Reducing the shim height on the upper clamps has the same effect as increasing the shim height on the outside.

Thicker shim on carbon upper clamp provides more rotation and off-power steering but decreases rear traction.

OPTION #990101 HUDY TITANIUM PIVOT BALL D=4.9 / S=5 / 3mm HEX (2)

OPTION #990008 HUDY TITANIUM BALL STUD D=4.9 / L=8 / S=3.5 / 2mm HEX (2)

- 4x 303122-K SHIM 3x6x1
- 2x 303123-K SHIM 3x6x2

UPPER ARMS CFF™ ALTERNATIVE FRONT SUSPENSION

INITIAL SETTING

NOTE ORIENTATION !

ASSEMBLY VIEW

FR-RL

FL-RR

1.0mm

1.0mm

8mm Thread

2.0mm

TIP Install with HUDY Multi Tool.

Front upper arm location affects the front roll-center and camber gain. Raising the arms with thicker shims on the upper clamps will lower the front roll-center and decrease camber gain. Reducing the shim height on the upper clamps has the same effect as increasing the shim height on the outside.

OPTION #990101 HUDY TITANIUM PIVOT BALL D=4.9 / S=5 / 3mm HEX (2)

OPTION #990008 HUDY TITANIUM BALL STUD D=4.9 / L=8 / S=3.5 / 2mm HEX (2)

5. FRONT & REAR SUSPENSION

ALTERNATIVE LINK STYLE UPPER ARMS

Replace the standard CFF upper arms. See full description below on when to use.

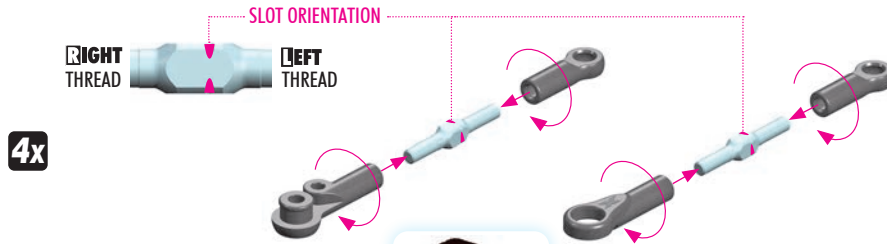

VIDEO TECH TIP



UPPER LINKS ADJUSTMENT

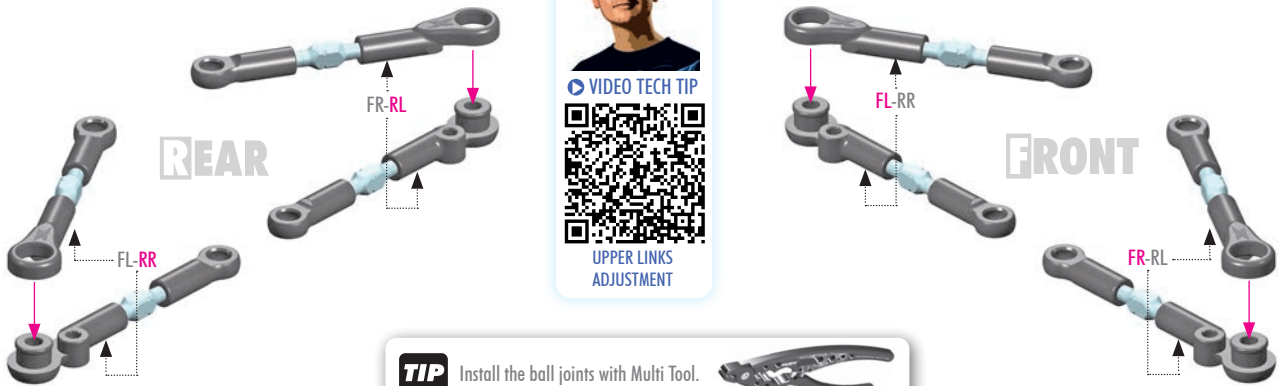

TIP Install the ball joints with Multi Tool.

LINK STYLE UPPER ARMS

The link style upper arms are also included in the kit as an alternative to the CFF arms, offering the freedom of choice to select the one with the preferred handling characteristics and adjustment capabilities.

Please see Page 54 for link adjustment instructions.

The added rigidity from the turnbuckles reduces flex of the suspension assembly, which has proven beneficial on certain track conditions such as medium to high traction asphalt and carpet. The car generates more initial reaction from the increased rigidity.

When switching from CFF to Upper Link arms, retain the same caster eccentric insert positions in the upper bulkheads as previously used.

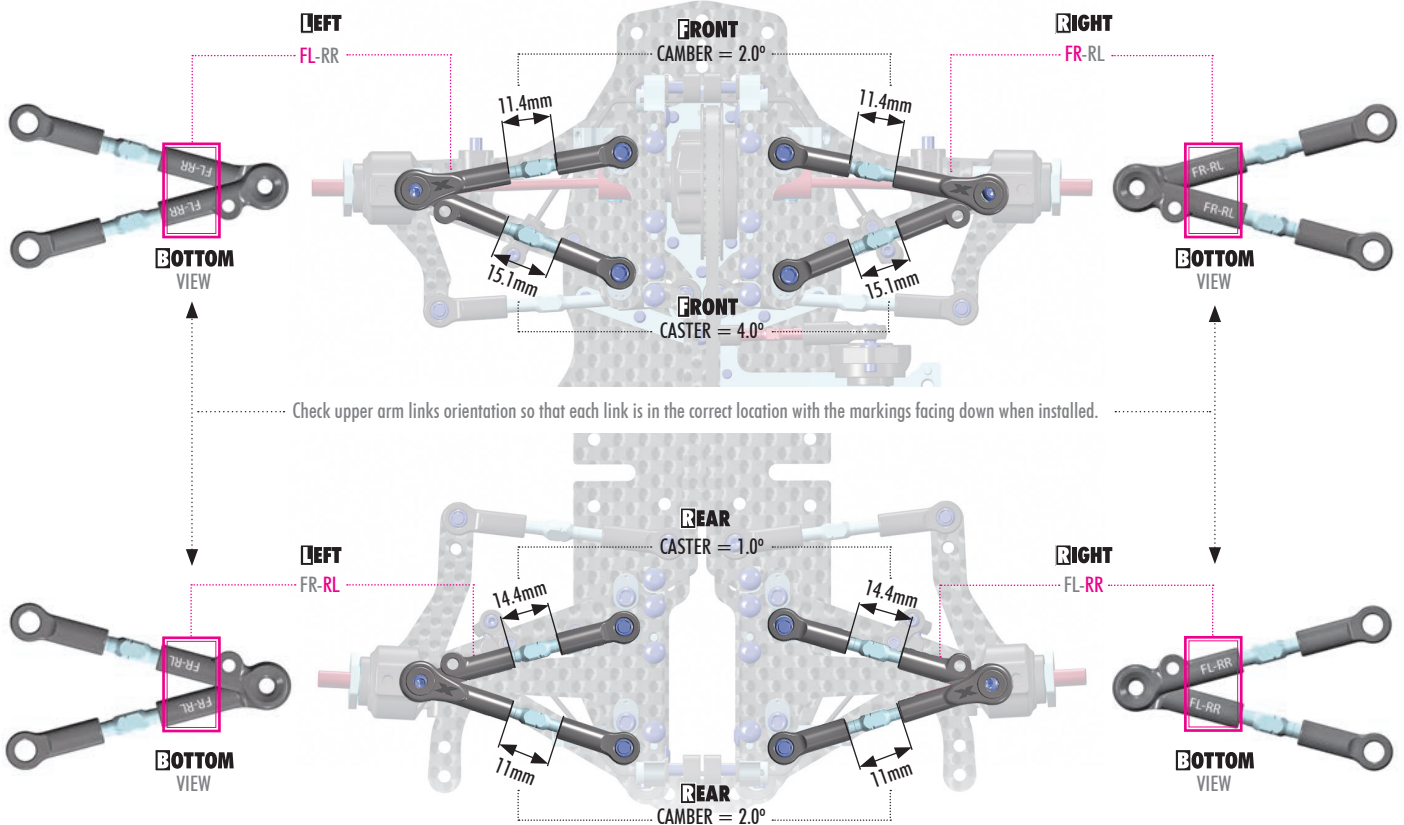

5. FRONT & REAR SUSPENSION

- 4x 303121-K SHIM 3x6x0.5
- 2x 303123-K SHIM 3x6x2

UPPER ARMS LINKS ALTERNATIVE

REAR SUSPENSION

ASSEMBLED VIEW

TIP Install with HUDY Multi Tool.

	HUDY TITANIUM BALL STUD	
OPTION	#990008 D=4.9 L=8 S=3.5	OPTION

	HUDY TITANIUM PIVOT BALL	
OPTION	#990101 D=4.9 S=5	OPTION

- 4x 303122-K SHIM 3x6x1
- 2x 303123-K SHIM 3x6x2

UPPER ARMS LINKS ALTERNATIVE

FRONT SUSPENSION

ASSEMBLED VIEW

TIP Install with HUDY Multi Tool.

	HUDY TITANIUM BALL STUD	
OPTION	#990008 D=4.9 L=8 S=3.5	OPTION

	HUDY TITANIUM PIVOT BALL	
OPTION	#990101 D=4.9 S=5	OPTION

2x REAR LINKS

LEFT THREAD RIGHT THREAD

2x L-R 18.2mm

	#303211-0 ALU TURNBUCKLE L/R	
OPTION	30mm ORANGE - SWISS 7075 T6 (2)	OPTION

5. FRONT & REAR SUSPENSION

4x 303123-K SHIM 3x6x2

2x REAR TRANSMISSION

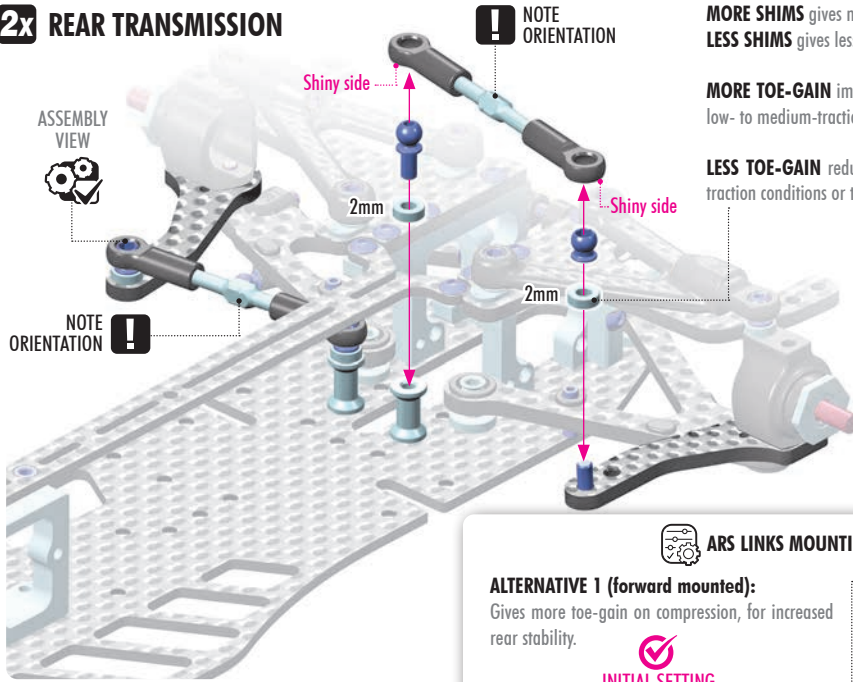

NOTE ORIENTATION

MORE SHIMS gives more toe-gain on compression.
LESS SHIMS gives less toe-gain (or even toe loss), on suspension compression.

MORE TOE-GAIN improves rear traction and side bite. Mainly recommended for low- to medium-traction conditions.

LESS TOE-GAIN reduces rear traction and side bite. Recommended for higher-traction conditions or tracks that require more steering.



ARS LINKS MOUNTING ALTERNATIVES

ALTERNATIVE 1 (forward mounted):

Gives more toe-gain on compression, for increased rear stability.

INITIAL SETTING



ALTERNATIVE 2 (rear mounted):

Gives less toe-gain on compression, for reduced rear stability.



HUDY TITANIUM BALL STUD
 #990008 | D=4.9 | L=8 | OPTION



HUDY TITANIUM PIVOT BALL
 #990102 | D=4.9 | S=3.5 | OPTION



VIDEO TECH TIP



REAR TOE-GAIN

2x 303127-K SHIM 3x6x4

2x FRONT TRANSMISSION

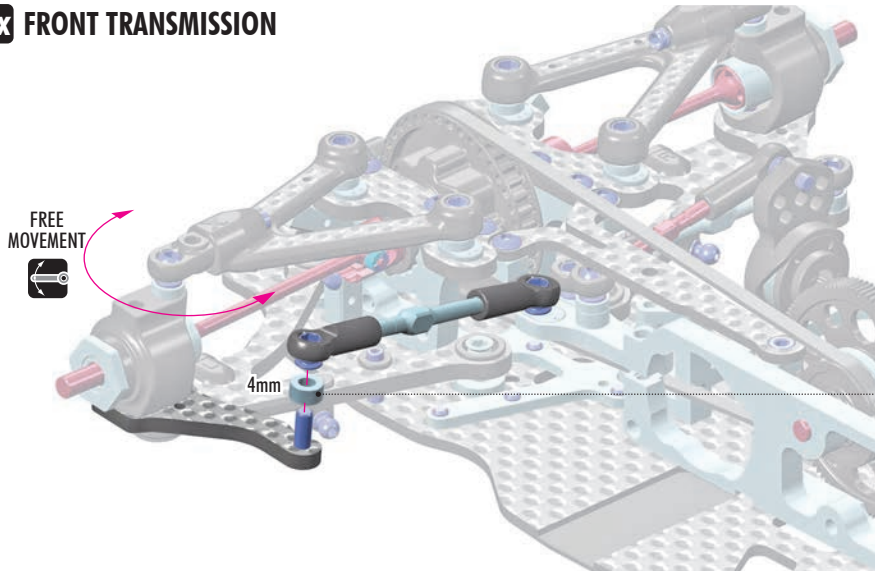

BUMP STEER ADJUSTMENT

TO DECREASE bump steer, smoothen out the steering, and reduce traction rolling: **increase the amount of shimming.**

TO INCREASE bump steer, to make the steering more aggressive, **decrease the amount of shimming.**

Decrease the amount of shimming to get more steering.

Increase the shimming if the car is difficult to drive and/or it is traction rolling.

VIDEO TECH TIP



STEERING SYSTEM

2x 930306 BB 3x6x2.5

2x FRONT & REAR ANTI-ROLL BARS

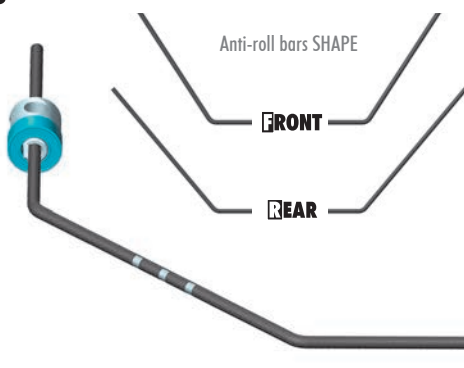

FRONT ANTI-ROLL BARS			
OPTION	#302841	1.1mm	OPTION
	#302842	1.2mm	OPTION
	#302843	1.3mm	INCLUDED

REAR ANTI-ROLL BARS			
OPTION	#303841	1.1mm	OPTION
	#303842	1.2mm	OPTION
	#303843	1.3mm	INCLUDED
	#303846	1.6mm	OPTION

#303848 1.8mm OPTION*
 *must be used with #303434 bushings

VIDEO TECH TIP



ANTI-ROLL BARS

5. FRONT & REAR SUSPENSION

4x ø3.8mm BALL
4mm THREAD

TIP Install with HUDY Multi Tool.

4x

ASSEMBLED VIEW

FULLY TIGHTEN

4x

As an initial setting, fully tighten. The anti-roll-bar will be set when the wire is mounted on the car.

REAR SUSPENSION

ASSEMBLED VIEW

- 2x 901302 SB M3x2.5
- 2x 901304 SB M3x4

REAR ANTI-ROLL BARS

OPTION	#303841	1.1mm	OPTION
	#303842	1.2mm	OPTION
	#303843	1.3mm	INCLUDED
	#303846	1.6mm	OPTION
	#303848	1.8mm	OPTION*
*must be used with #303434 bushings			

SOFTER rear anti-roll bar:
Generates more side traction. Mainly recommended for low-traction asphalt tracks.

STIFFER rear anti-roll bar:
Helps the car stay flatter and reduces traction rolling on high-traction surfaces.

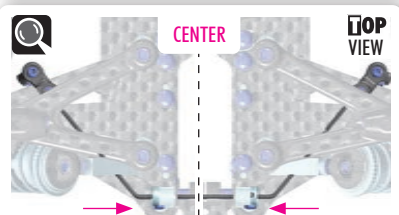

Set the bar into the **CENTER**, remove the play in the bushings, and tighten the set-screws fully.

ANTI-ROLL BAR ADJUSTMENT

If both sides **DO NOT** respond at the same time, adjust the length of the bar holders to achieve equal L&R response.

! The length of the anti-roll bars may vary. It is therefore very important to always check that the ball joint does not touch the arm, otherwise the suspension will not move freely.

PLAY

1.5 mm

3x4mm

3x4mm

3x2.5mm

3x2.5mm

! **NOTE THE ORIENTATION** of the alu anti-roll bar bushing. The hole for the set-screw must be in-line with bulkhead cutout to allow the full movement of the anti-roll bar wire.

When the bars are set, verify that both sides move at the same time. If they do, the bars are set up correctly. If **NOT**, make sure that both downstops are the same and that the bar wire is flat.

VIDEO TECH TIP

ANTI-ROLL BARS

5. FRONT & REAR SUSPENSION

FRONT SUSPENSION

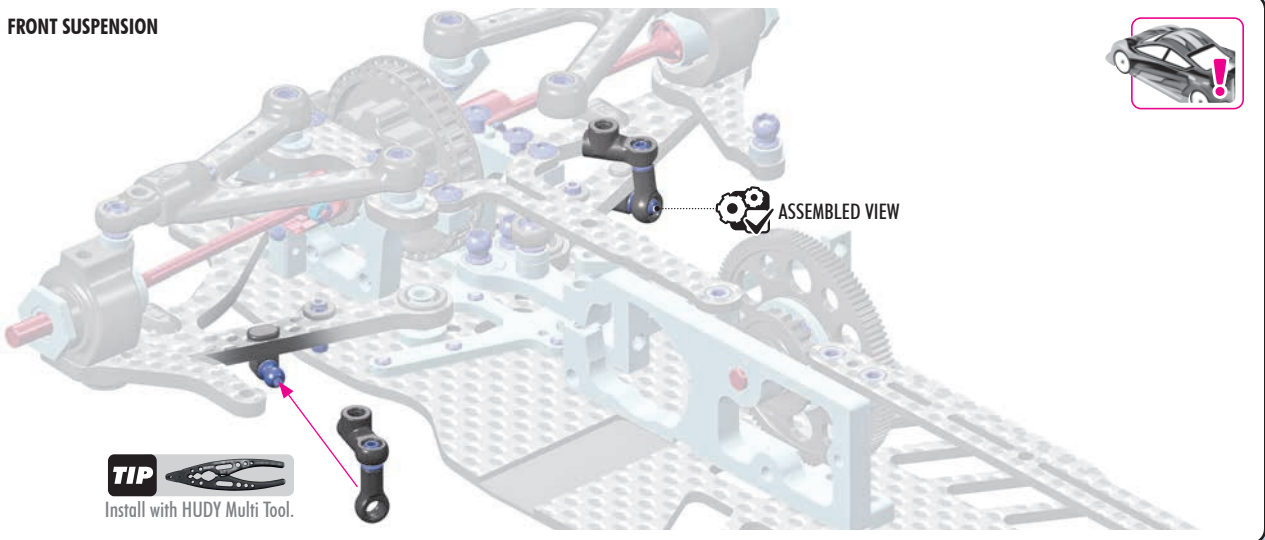

2x 901302
SB M3x2.5

2x 901304
SB M3x4

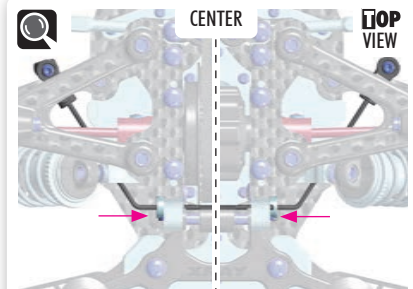
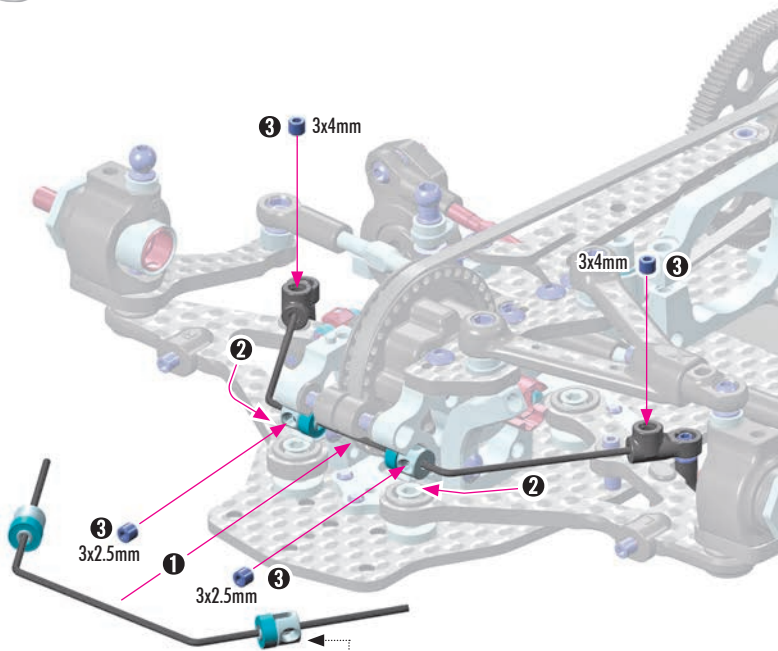

Set the bar into the **CENTER**, remove the play in the bushings, and tighten the set-screws fully.

IMPORTANT! Check for clearance between the steering plate and anti-roll bar. If there is contact when setting the steering angle up to the maximum 26°, ensure that the anti-roll bar is properly centered.

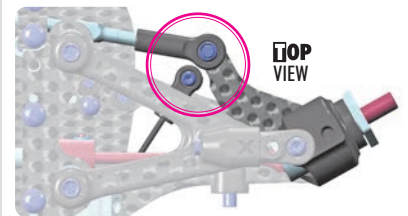

! NOTE THE ORIENTATION of the alu anti-roll bar bushing. The hole for the set-screw must be in-line with bulkhead cutout to allow the full movement of the anti-roll bar wire.

ANTI-ROLL BAR ADJUSTMENT

If both sides do not respond at the same time, adjust the length of the bar holders to achieve equal L&R response.

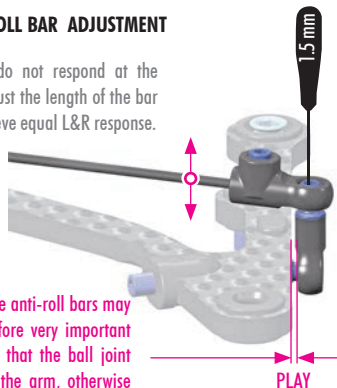

! The length of the anti-roll bars may vary. It is therefore very important to always check that the ball joint does not touch the arm, otherwise the suspension will not move freely.



FRONT ANTI-ROLL BARS

OPTION	FRONT ANTI-ROLL BARS	OPTION
#302841	1.1mm	OPTION
#302842	1.2mm	OPTION
#302843	1.3mm	INCLUDED

SOFTER front anti-roll bar:

Allows the front to roll more which provides more front traction and improves on-power steering.

STIFFER front anti-roll bar:

Makes the car initially more responsive, and helps the car stay flatter on fast direction changes. Reduces steering from mid-corner to corner exit. Mainly recommended for high-traction carpet.

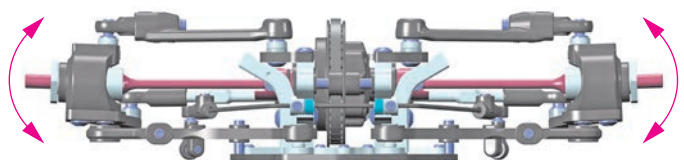

! When the bars are set, verify that both sides move at the same time. If they do, the bars are set up correctly. If NOT, make sure that both downstops are the same and that the bar wire is flat.



VIDEO TECH TIP



ANTI-ROLL BARS

6. SHOCK ABSORBERS

4x

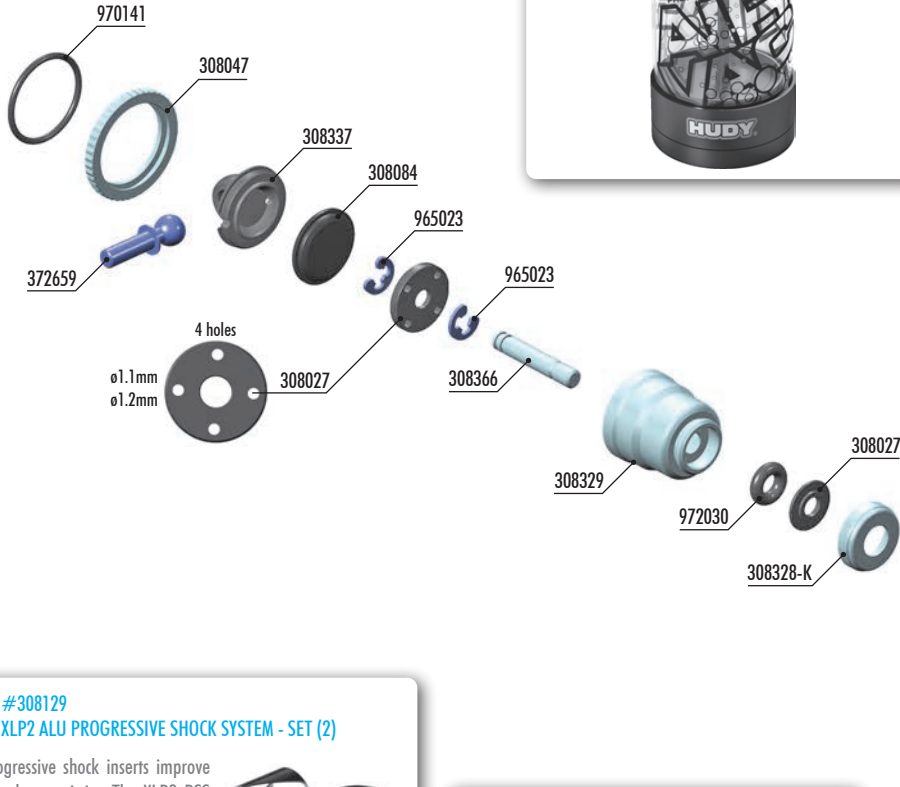

#104002 or #104003
HUDY AIR VAC – VACUUM PUMP - ON-ROAD

OPTION

XRAY SPRINGS		
#308164	C = 2.4-2.7	OPTION
#308165	C = 2.5-2.8	INCLUDED
#308166	C = 2.6-2.9	OPTION
#308175	C = 2.5	OPTION
#308176	C = 2.6	INCLUDED
#308177	C = 2.7	OPTION
#308178	C = 2.8	OPTION
#308179	C = 2.9	OPTION
#308180	C = 3.0	OPTION

#308129
XLP2 ALU PROGRESSIVE SHOCK SYSTEM - SET (2)

The progressive shock inserts improve steering characteristics. The XLP2 PSS set fits the stock XLP2 shock bodies included in the kit. Must be used with: #308026 - XLP Progressive Pistons.



#308026
XLP COMPOSITE 2-HOLE ø0.8mm PROGRESSIVE PISTON (4)



OPTION **HUDY TITANIUM PIVOT BALL**
 #990102 | D=4.9 | S=3.5 | OPTION



OPTION **#308033-K**
ALU XLP SHOCK SPRING RETAINING COLLAR - BLACK (4)



VIDEO TECH TIP SHOCKS & SPRINGS

BAG

06

308027	XLP COMPOSITE 4-HOLE 1.1-1.2mm PISTON (2+2)	372659	BALL END 4.9mm WITH 9mm THREAD (2)
308047	XLP2 ALU SHOCK ADJUSTABLE NUT - BLACK (2)	965023	E-CLIP 2.3 (10)
308084	XLP2 SILICONE HYPER RESISTANT MEMBRANE (4)	970141	O-RING 14 x 1.0 (10)
308311	XLP2 ALU SHOCK ABSORBER-SET (2)	972030	SILICONE O-RING 3 x 2 (10)
308329	XLP2 ALU SHOCK BODY (2)	308165	XLP SPRING-SET PROGRESSIVE C=2.5-2.8 (2)
308328-K	XLP ALU CAP FOR SHOCK BODY - BLACK (2)	308176	XLP SPRING-SET C=2.6 (2)
308337	XLP2 COMPOSITE SHOCK PARTS WITH 2 HOLES		
308366	XLP2 HARDENED SHOCK SHAFT (2)		
372651	PIVOT BALL UNIVERSAL 4.9mm - HUDY SPRING STEEL™ (2)		

Numbers in parentheses () refer to quantities when purchased separately.

8x 965023
 E 2.3

4x **INITIAL SETTING**

4 holes ø1.1mm ø1.2mm **INITIAL SETTING**

NOTE ORIENTATION

#308026
XLP COMPOSITE 2-HOLE ø0.8mm PROGRESSIVE PISTON (4)

These pistons must be used with optional: #308129 XLP2 PROGRESSIVE SHOCK INSERTS

6. SHOCK ABSORBERS



4x 972030
0 3x2

4x

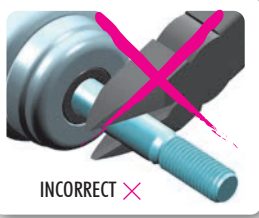
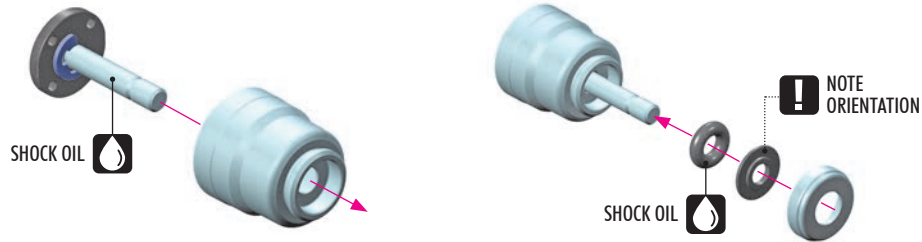

INCORRECT X

4x

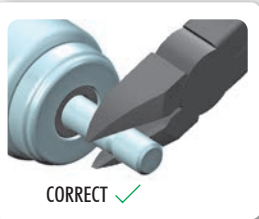
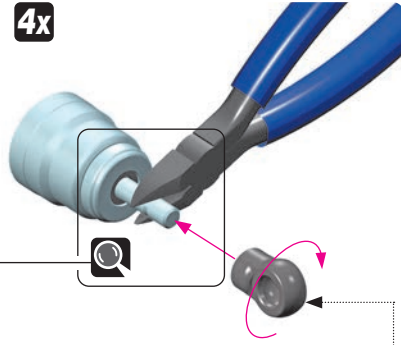

CORRECT ✓

Pre-thread the ball joint using an M3 screw. **TIP**

Be careful NOT to pre-thread too far, since the ball joint may split or the plastic threads may strip out. **!**

4x

The necessary shock length depends on the downstop setting. When using minimum downstop, increase the shock length.

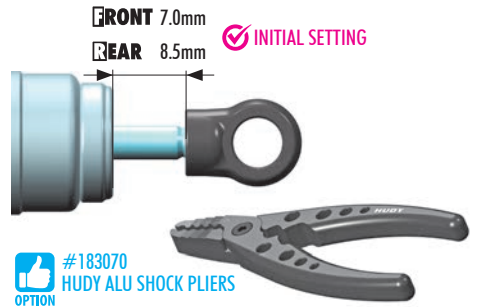

#183070
HUDY ALU SHOCK PLIERS

We recommend using HUDY shock pliers when adjusting shock length. These pliers allows super easy and comfortable shock length adjustment.



VIDEO TECH TIP



HUDY AIR-VAC SHOCK BUILD

OIL 350cSt

4x

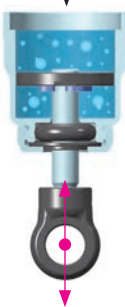

SHOCK FILLING

- 1 Fully extend the piston rod so the piston is at the bottom of the shock body.
- 2 Hold the shock upright and slightly overfill the shock body with shock oil.
- 3 Let the oil settle and allow air bubbles to rise to the top. Slowly move the piston up and down to allow oil into all cavities within the shock body.
- 4 Extend the piston rod most of the way out of the shock body. Let the shock rest for 5 minutes to allow the air bubbles to escape.
- 5 Add shock oil as necessary.



SHOCK OILS (50ml)		
#106325	250cSt	OPTION
#106330	300cSt	OPTION
#106335	350cSt	INCLUDED
#106337	375cSt	OPTION
#106340	400cSt	OPTION
#106342	425cSt	OPTION
#106345	450cSt	OPTION
#106347	475cSt	OPTION
#106350	500cSt	OPTION

#106352	525cSt	OPTION
#106355	550cSt	OPTION
#106357	575cSt	OPTION
#106360	600cSt	OPTION
#106362	625cSt	OPTION
#106365	650cSt	OPTION
#106367	675cSt	OPTION
#106370	700cSt	OPTION
#106375	750cSt	OPTION
#106380	800cSt	OPTION

TIP



#104002 or #104003
HUDY AIR VAC – VACUUM PUMP



To make sure that all the air is removed from the shock oil, we recommend using the HUDY Air Vac.



REBOUND ADJUSTMENT

IMPORTANT

When building the shocks with brand new membranes, some rebound may occur. After a few runs, or letting the shock settle for 24 hours, the membrane will break-in and zero rebound will be possible.

Insert shock membrane.



0~25% Rebound
INITIAL SETTING

For most conditions, 0-25% rebound is recommended. This is the most forgiving and best to absorb bumps. Cornering speed is generally the best with this setting.

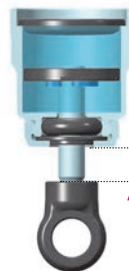

50% Rebound



100% Rebound

For certain low traction conditions, adding additional rebound may improve initial reaction and side bite. Direction change will be faster and may feel like the car is creating more traction. Note that higher rebound settings will make the car less stable over bumps and may increase the tendency to traction roll.

6. SHOCK ABSORBERS

Gently and very slowly push shock membrane to remove excess oil.

4x

! To prevent any damage to the shock body, gently tighten the shock cap. Excessive force or overtightening can cause the shock body to break or split.

CORRECT ✓

INCORRECT ✗

SHOCK OIL

4x

ASSEMBLED VIEW

4x 970141
014x1.0

4x

! **NOTE ORIENTATION**

Note the orientation of the shock collar. The XLP2 shocks are designed with the spring centered on the shock body and not the spring collar with the threaded portion of the collar towards the top of the shock.

VIDEO TECH TIP

SHOCKS & SPRINGS

SHOCK LENGTH ADJUSTMENT:

! It is **VERY IMPORTANT** that all shocks are equal length.

Fully extend the shock absorber and measure the end-to-end length; we recommend using digital calipers to give an accurate measurement. If a shock absorber is shorter or longer than others, adjust the shock length by tightening or loosening the ball joint on the shock rod.

4x

o4.9mm BALL
9mm THREAD

Laser engraved springs.

FRONT C = 2.5-2.8
REAR C = 2.6

TIP Install with HUDY Multi Tool.

ASSEMBLED VIEW

OPTION HUDY TITANIUM PIVOT BALL #990102 D=4.9 S=3.5 **OPTION**

OPTION #308033-K ALU XLP SHOCK SPRING RETAINING COLLAR - BLACK (4)

7. FRONT & REAR ASSEMBLY

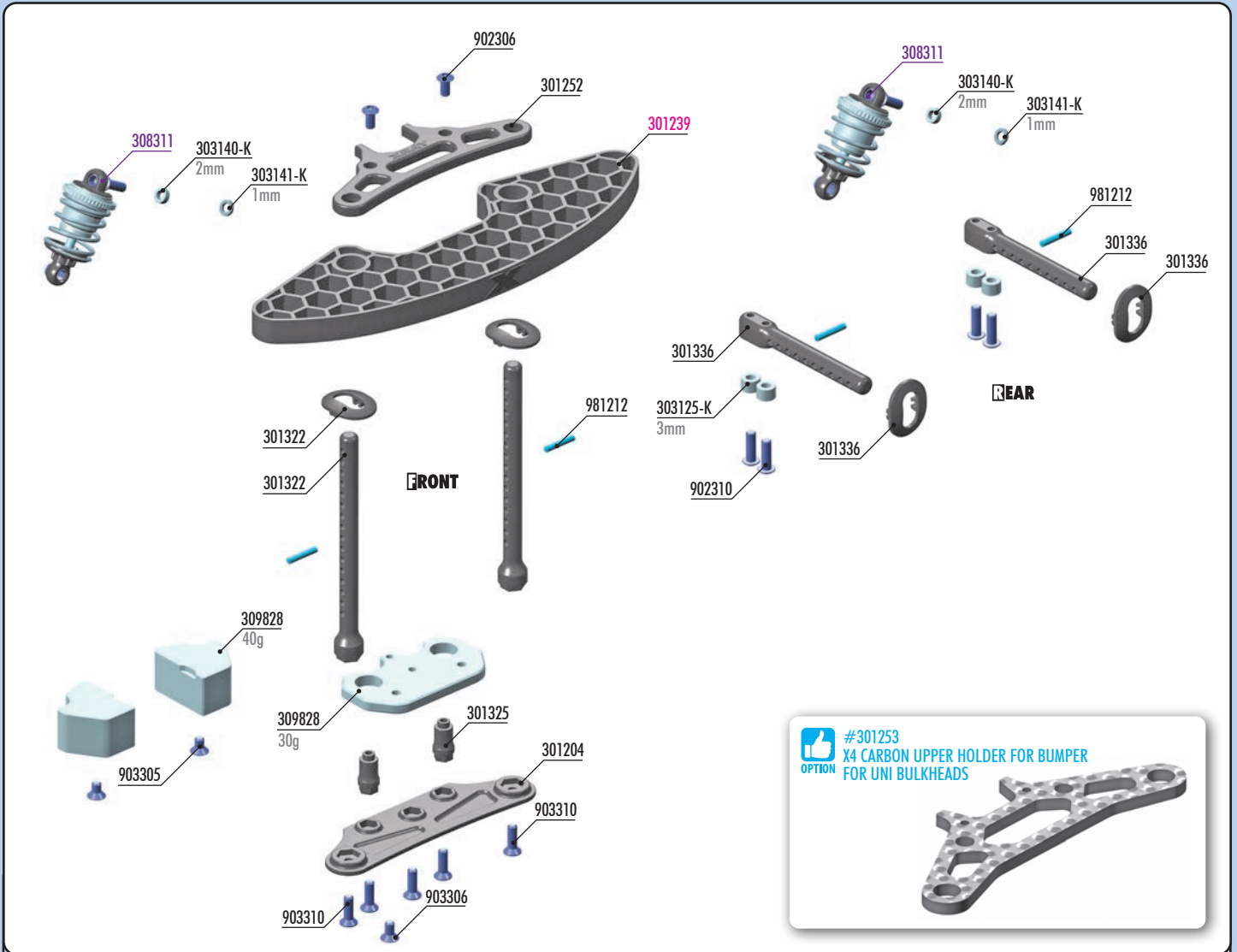

BAG
07

- 301204 COMPOSITE BUMPER
- 301252 X4 COMPOSITE UPPER HOLDER FOR BUMPER FOR UNI BULKHEADS
- 301322 FRONT BODY MOUNT SET
- 301325 COMPOSITE BRACE FOR BUMPER - LOW (2)
- 301336 COMPOSITE REAR 6MM ADJUSTABLE BODY MOUNT SET
- 303125-K ALU SHIM 3x6x3.0mm - BLACK (10)
- 303140-K ALU SHIM 3x5x2.0mm - BLACK (10)
- 303141-K ALU SHIM 3x5x1.0mm - BLACK (10)
- 309828 X4F BALANCING WEIGHT - CENTER & FRONT L&R (30g + 40g + 40g)

- 902306 HEX SCREW SH M3x6 (10)
- 902310 HEX SCREW SH M3x10 (10)
- 903305 HEX SCREW SFH M3x5 (10)
- 903306 HEX SCREW SFH M3x6 (10)
- 903310 HEX SCREW SFH M3x10 (10)
- 981212 PIN 2x12 (10)
- 301239 X4F RUBBER BUMPER 3D LOW PROFILE
- 308311 XLP2 ALU SHOCK ABSORBER-SET - BLACK (2)

Numbers in parentheses () refer to quantities when purchased separately.

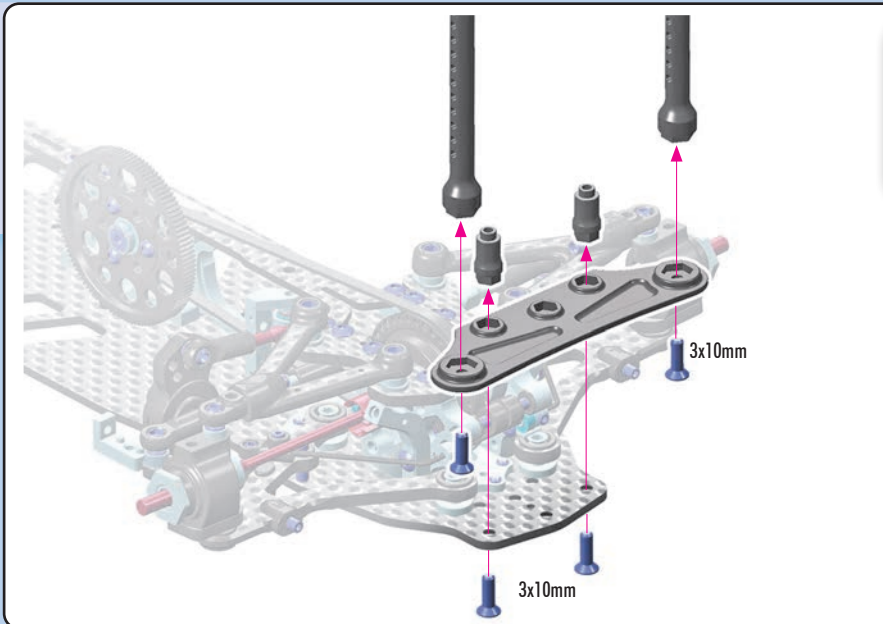

FRONT BODY MOUNT SET			
#301322	0mm	INCLUDED	
#301323	+1mm	OPTION	
#301324	+2mm	OPTION	



7. FRONT & REAR ASSEMBLY



1x 903306 SFH M3x6



1x 903310 SFH M3x10

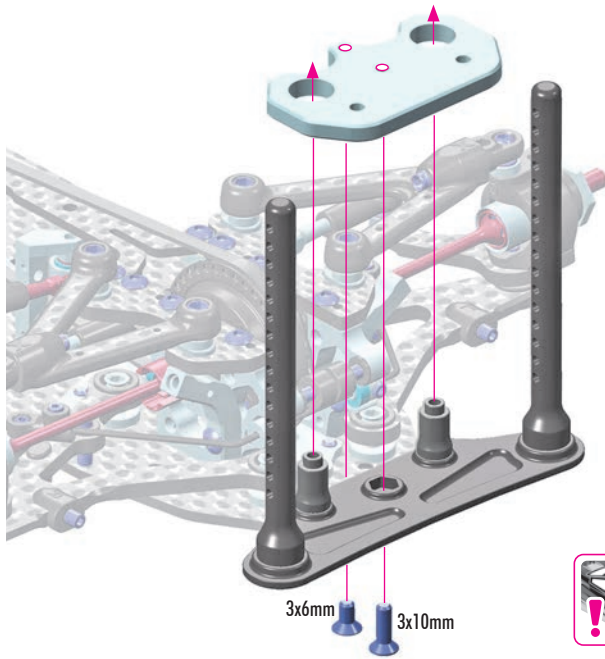

3x6mm 3x10mm



#293085 HUDY PURE TUNGSTEN WEIGHT THIN ROUND WITH M3 - 10g

For very low- to medium-traction conditions, we recommend adding extra weight on top of the center weight. The easiest solution is to use the #293085 HUDY PURE TUNGSTEN WEIGHT (10g), which can be mounted on top of the center weight. The additional weight helps increase the car's stability and forward traction.

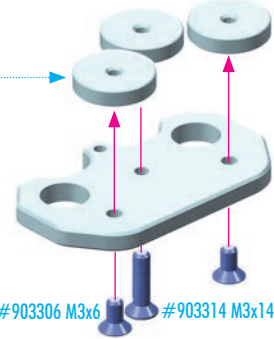

#903306 M3x6 #903314 M3x14



2x 903305 SFH M3x5

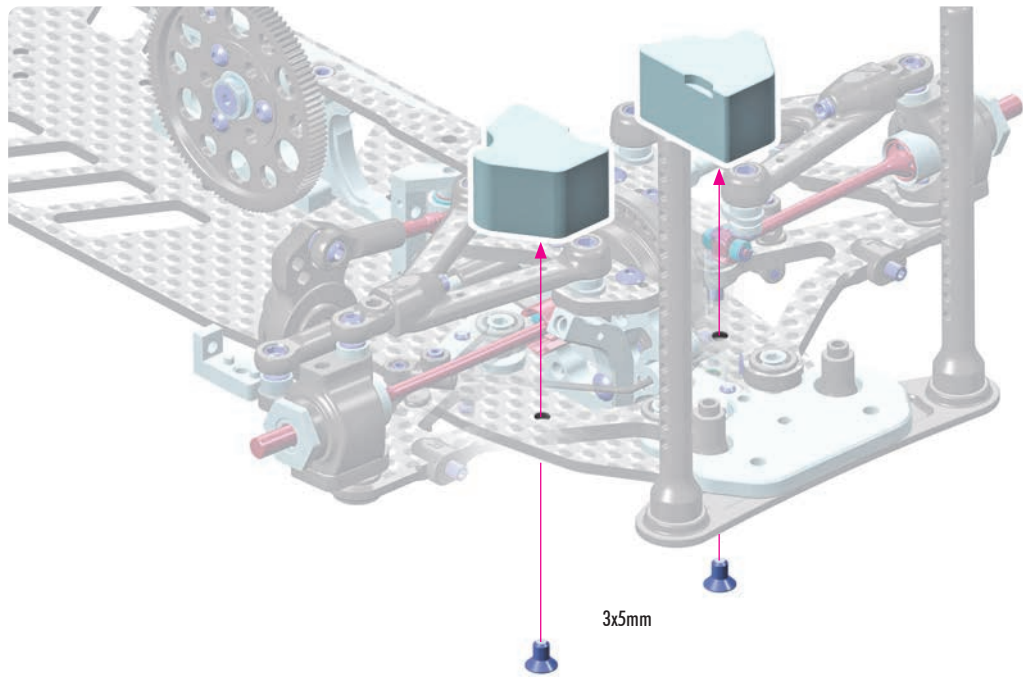

3x5mm

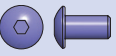

2x 902306 SH M3x6

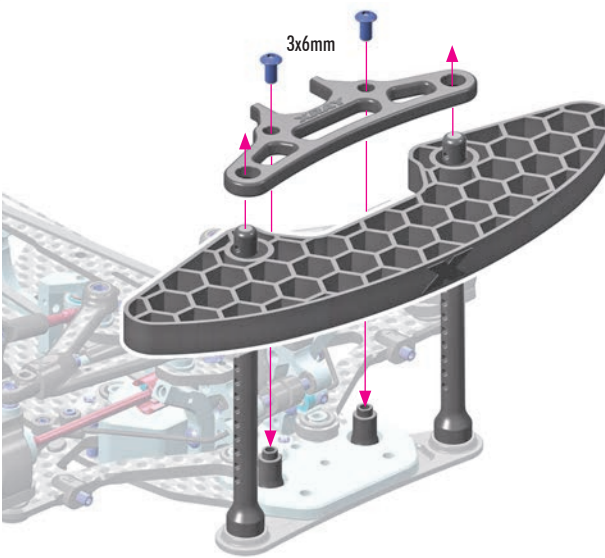

3x6mm

NOTE ORIENTATION when inserting the bumper

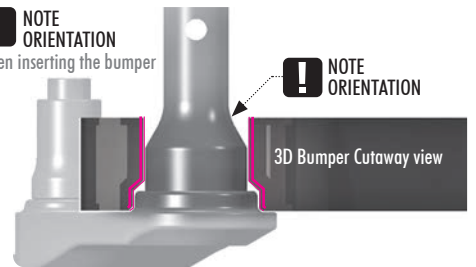

NOTE ORIENTATION

3D Bumper Cutaway view



#301253 X4 CARBON UPPER HOLDER FOR BUMPER FOR UNI BULKHEADS



7. FRONT & REAR ASSEMBLY

2x 981212
P 2x12

2x L=R



#301351-0
ALU ADJUSTABLE BODY
POST STOP (2)



#301351-K
ALU ADJUSTABLE BODY
POST STOP (2)



Very handy, easily externally adjustable body post made from Swiss 7075 T6 aluminum. Allows for adjustment of body height by 3mm without needing to change the position on the body post.



FRONT BODY MOUNT SET

#301322	0mm	INCLUDED
#301323	+1mm	OPTION
#301324	+2mm	OPTION



VIDEO TECH TIP



FRONT BODY UPSTOP SYSTEM

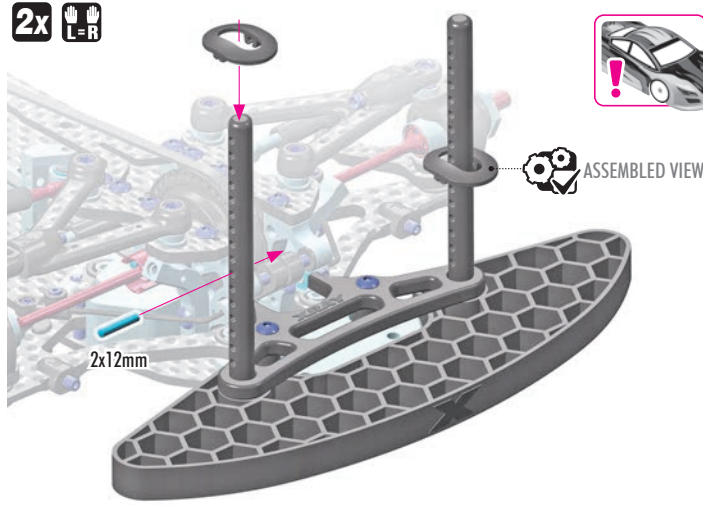

2x 303140-K
SHIM 3x5x2

2x 303141-K
SHIM 3x5x1



VIDEO TECH TIP



SHOCKS & SPRINGS

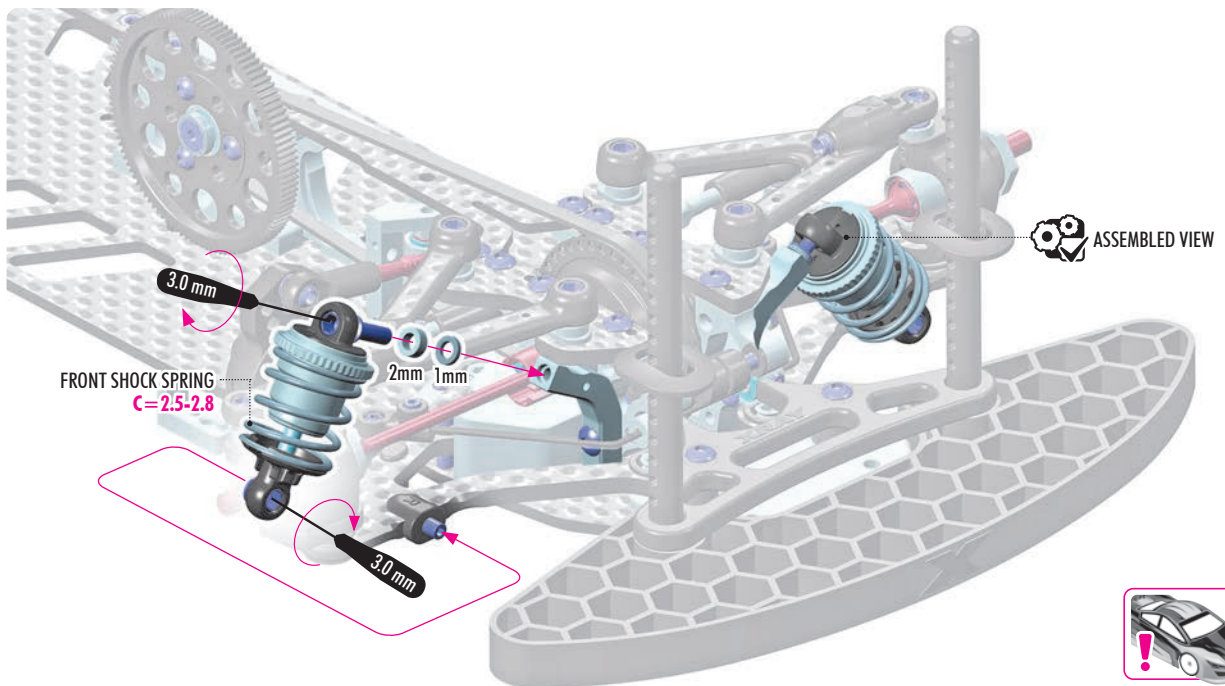

1mm on X4F'26 = 0mm on X4F'27.

INITIAL SETTING

2mm shims - CARPET TRACKS



2mm shim

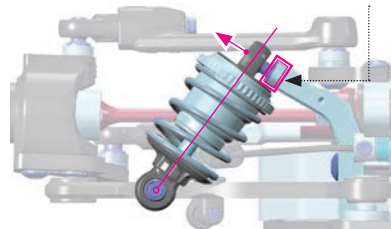

INITIAL SETTING

1mm shims - ASPHALT TRACKS



1mm shim

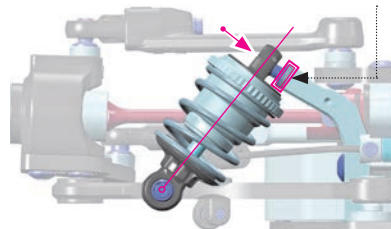

#308129
XLP2 ALU PROGRESSIVE SHOCK SYSTEM - SET (2)

The progressive shock inserts improve steering characteristics. The XLP2 PSS set fits the stock XLP2 shock bodies included in the kit. Must be used with #308026 - XLP Progressive Pistons.



#308026
XLP COMPOSITE 2-HOLE
ø0.8mm PROGRESSIVE
PISTON (4)



7. FRONT & REAR ASSEMBLY

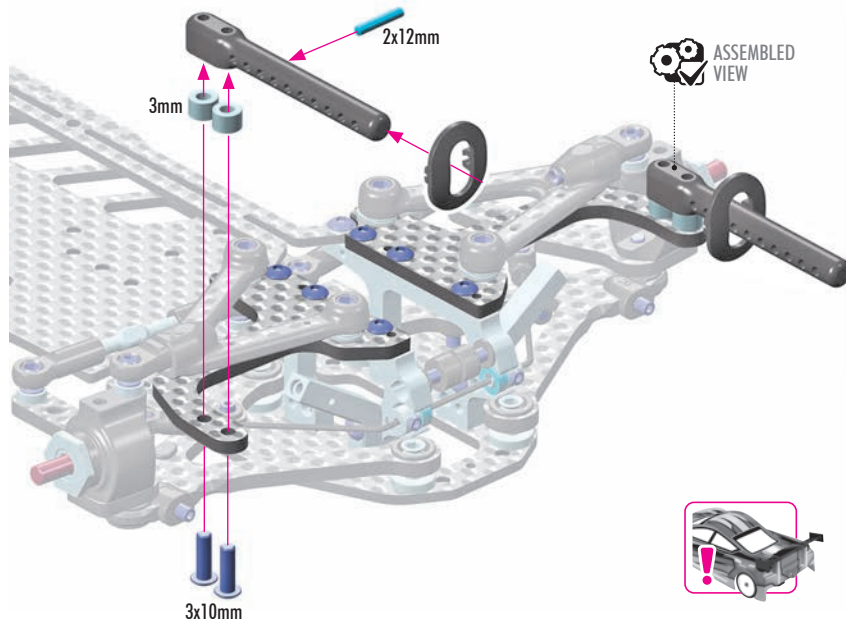
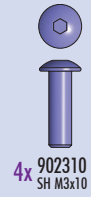

#301351-0
ALU ADJUSTABLE BODY POST STOP (2)
OPTION



#301351-K
ALU ADJUSTABLE BODY POST STOP (2)
OPTION



Very handy, easily externally adjustable body post made from Swiss 7075 T6 aluminum. Allows for adjustment of body height by 3mm without needing to change the position on the body post.

REAR BODY MOUNT SET
OPTION

#301336	0mm	INCLUDED
#301337	+1mm	OPTION
#301338	+2mm	OPTION

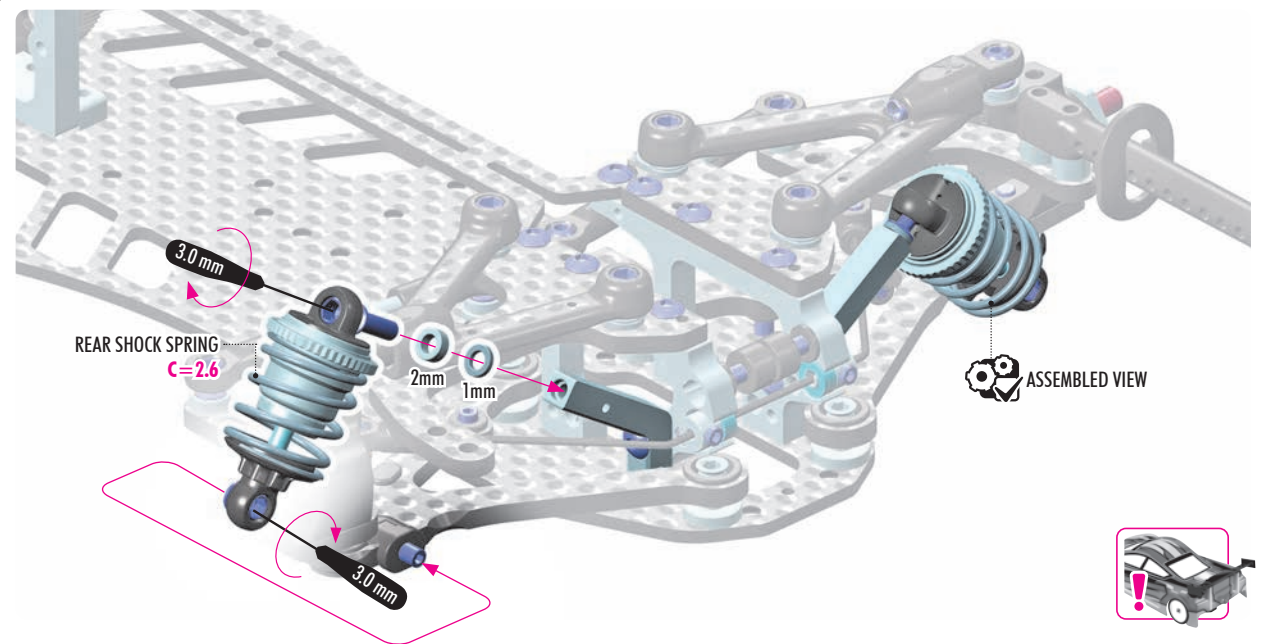

REAR SHOCK SPRING
C=2.6

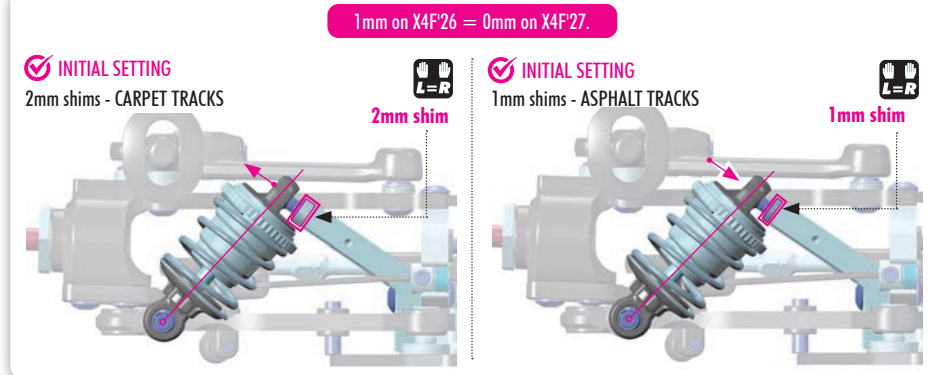

INITIAL SETTING
2mm shims - CARPET TRACKS

2mm shim

INITIAL SETTING
1mm shims - ASPHALT TRACKS

1mm shim



VIDEO TECH TIP



SHOCK SHIMMING TUTORIAL

#308129
XLP2 ALU PROGRESSIVE SHOCK SYSTEM - SET (2)
OPTION

The progressive shock inserts improve steering characteristics. The XLP2 PSS set fits the stock XLP2 shock bodies included in the kit. Must be used with #308026 - XLP Progressive Pistons.



#308026
XLP COMPOSITE 2-HOLE ø0.8mm PROGRESSIVE PISTON (4)
OPTION



7. FINAL ASSEMBLY

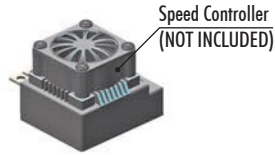

OPTION 305912~294164
NARROW ALU PINION GEAR 12T~64T



LiPo Battery Pack (NOT INCLUDED)

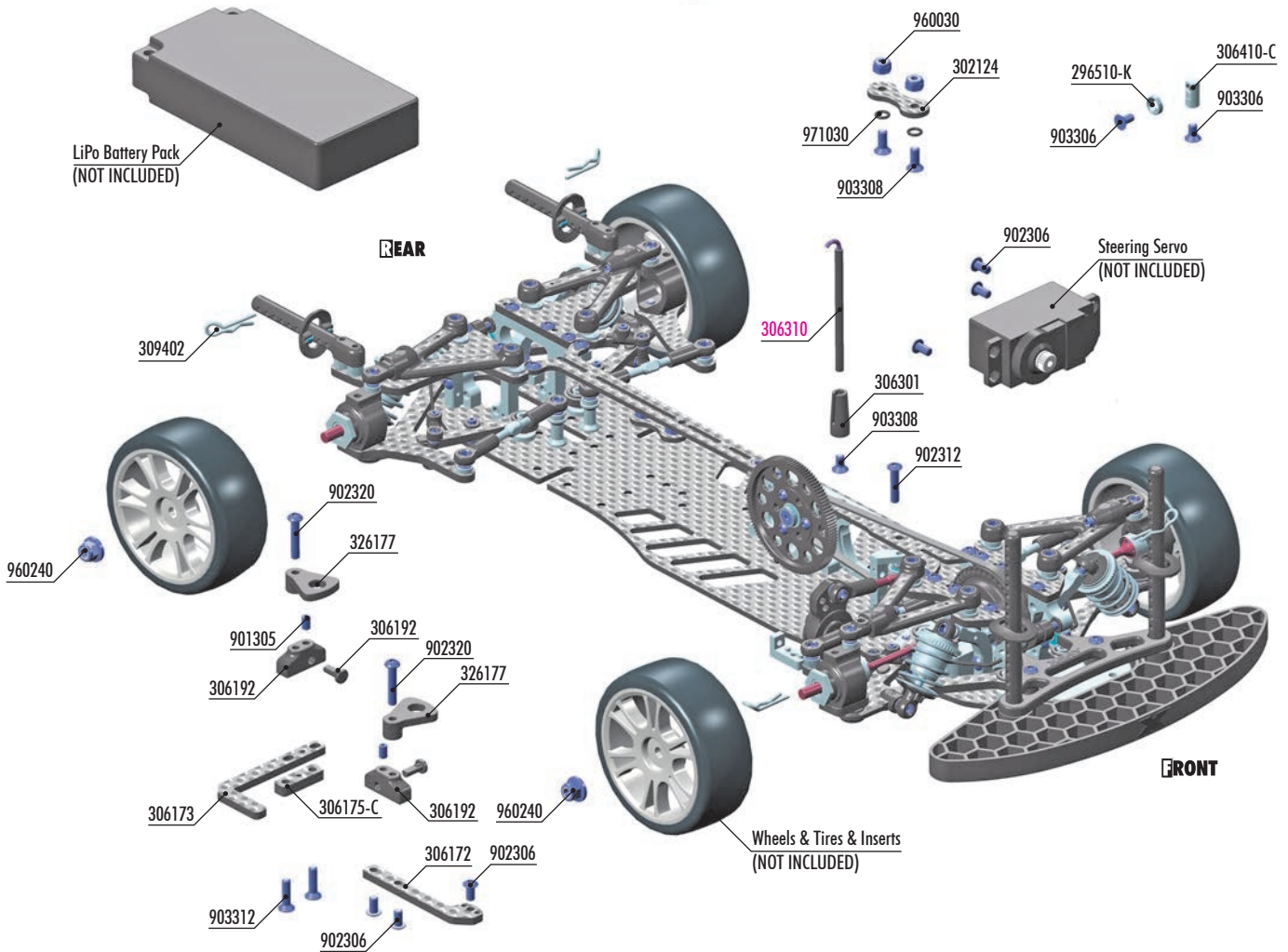

OPTION HUDY ALU RC FAN 30mm & 40mm (on page 48)



OPTION TUNGSTEN & STAINLESS STEEL WEIGHTS (on page 52)



OPTION #306410 ALU FAN MOUNT



OPTION ALU REAR WING SHIM

#	COLOR	BRAND	OPTION
#353561	SILVER	XRAY	OPTION
#293561	SILVER	HUDY	OPTION
#293561-K	BLACK	HUDY	OPTION
#293561-O	ORANGE	HUDY	OPTION



BAG

07

305912~294164 NARROW ALU PINION GEAR 12T~64T (OPTION)

- 296510-K ALU COUNTERSUNK SHIM - BLACK (10)
- 302124 X4 REAR ROLL-CENTER CARBON SPACER 1+2MM (1+1)
- 303125-K ALU SHIM 3x6x3.0mm - BLACK (10)
- 303790 ALU ECCENTRIC MOTOR BULKHEAD INSERT
- 306172 X4F CARBON BATTERY HOLDER - FRONT
- 306173 X4F CARBON BATTERY HOLDER - REAR
- 306175-C CARBON BATTERY PLATE SHIM (2)
- 306192 COMPOSITE ADJUSTABLE BATTERY HOLDER & BACKSTOP (2+2)
- 306301 ANTENNA MOUNT - THIN
- 306410-C ALU UNIVERSAL MOUNT
- 309402 BODY CLIP FOR 6mm BODY POST (4)
- 326177 COMPOSITE BATTERY CLAMP (2)

- 901305 HEX SCREW SB M3x5 (10)
- 902306 HEX SCREW SH M3x6 (10)
- 902310 HEX SCREW SH M3x10 (10)
- 902312 HEX SCREW SH M3x12 (10)
- 902320 HEX SCREW SH M3x20 (10)
- 903306 HEX SCREW SFH M3x6 (10)
- 903308 HEX SCREW SFH M3x8 (10)
- 903312 HEX SCREW SFH M3x12 (10)
- 960030 NUT M3 (10)
- 960240 NUT M4 WITH SERRATED FLANGE (10)
- 971030 SILICONE O-RING 3x1.5 (10)

306310 ANTENNA (2)

Numbers in parentheses () refer to quantities when purchased separately.

7. FINAL ASSEMBLY

! SERVO WIRE
The motor mount features a cut-out for the servo wire to pass underneath.

! SERVO WIRE
(Untight the motor mount screws)
The motor mount features a cut-out for the servo wire to pass underneath. When installing servo, loosen the motor mount, place the servo wire in the groove, and then tighten the motor mount and top deck.

3x 902306 SH M3x6

VIDEO TECH TIP

STEERING SYSTEM

From Servo

3x6mm ②

3x6mm ②

① ④

3x5x1mm Shim

3x7x1mm Shims

SERVO AND SERVO SAVER POSITION ADJUSTMENT.
Due to variations in servo sizes, shims may be required to provide proper clearance and alignment between the servo, servo saver and servo mount.

- Use 3x5x1mm size shims between the servo and servo saver to move the servo saver out from servo mount.
- Use 3x7x1mm size shims between servo and servo mount to move the servo more back.

! CAN NOT touch.

! SERVO WIRE

90°

! SERVO WIRE

Attach servo arm to servo output shaft using screw from servo. Servo saver must be perpendicular to chassis when servo is in neutral.

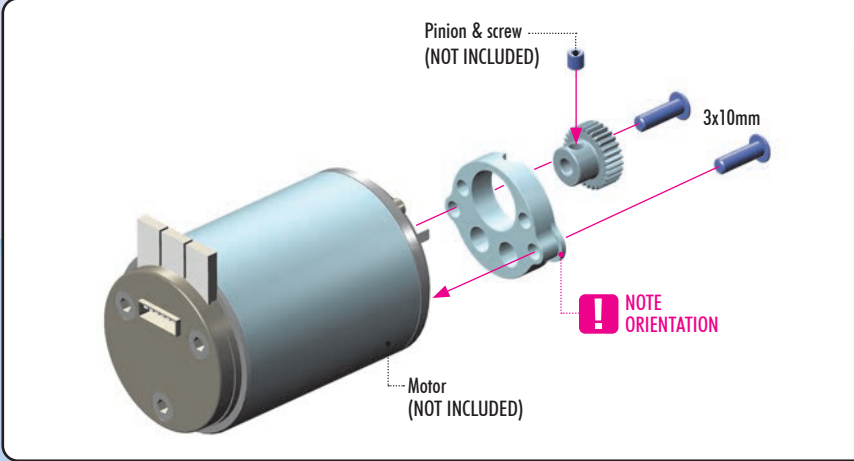
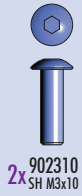

ALU PINION GEARS (OPTION)

#305912 12T / 48P	#305968 18T / 64P
#305913 13T / 48P	#305969 19T / 64P
#305914 14T / 48P	#294120 20T / 64P
#305915 15T / 48P	#305971 21T / 64P
#305916 16T / 48P	#305972 22T / 64P
#294017 17T / 48P	#294123 23T / 64P
#294018 18T / 48P	#294124 24T / 64P
#294019 19T / 48P	#294125 25T / 64P
#294020 20T / 48P	#294126 26T / 64P
#294021 21T / 48P	#294127 27T / 64P
#294022 22T / 48P	#294128 28T / 64P
#294023 23T / 48P	#294129 29T / 64P
#294024 24T / 48P	#294130 30T / 64P
#294025 25T / 48P	#294131 31T / 64P
#294026 26T / 48P	#294132 32T / 64P
#294027 27T / 48P	#294133 33T / 64P
#294028 28T / 48P	#294134 34T / 64P
#305929 29T / 48P	#294135 35T / 64P
#294030 30T / 48P	#294136 36T / 64P
#305931 31T / 48P	#294137 37T / 64P
#294032 32T / 48P	#294138 38T / 64P
#294033 33T / 48P	#294139 39T / 64P
#305934 34T / 48P	#294140 40T / 64P
#294035 35T / 48P	#294141 41T / 64P
	#294142 42T / 64P
	#294143 43T / 64P
	#294144 44T / 64P
	#294145 45T / 64P
	#294146 46T / 64P
	#294147 47T / 64P
	#294148 48T / 64P
	#294149 49T / 64P
	#294150 50T / 64P
	#294152 52T / 64P
	#294154 54T / 64P
	#294156 56T / 64P
	#294158 58T / 64P
	#294160 60T / 64P
	#294162 62T / 64P
	#294164 64T / 64P

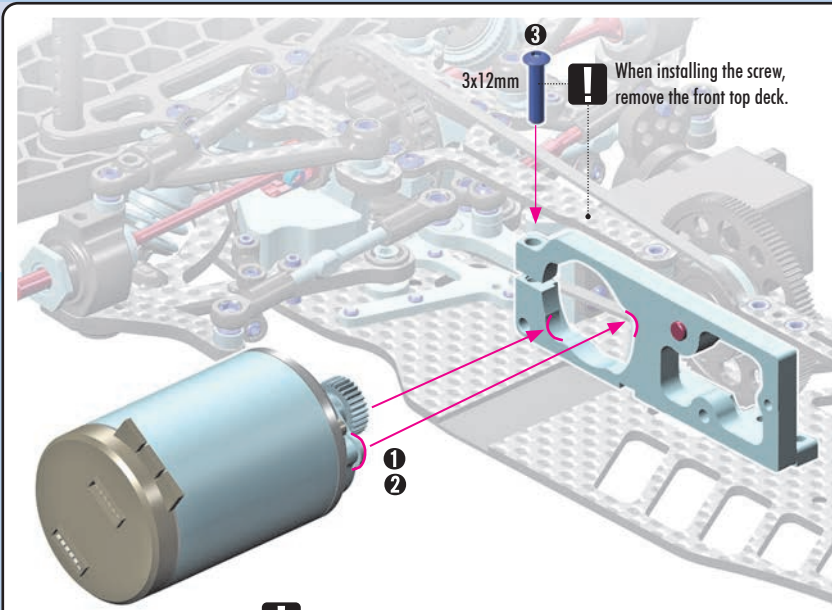
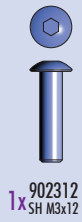

NOTE

The most-used FWD ratios are 4.5 and 5. Use these recommended spur gears and pinions to achieve the desired ratio.

4.5 ratio - 90T spur / 38T pinion

5 ratio - 100T spur / 38T pinion

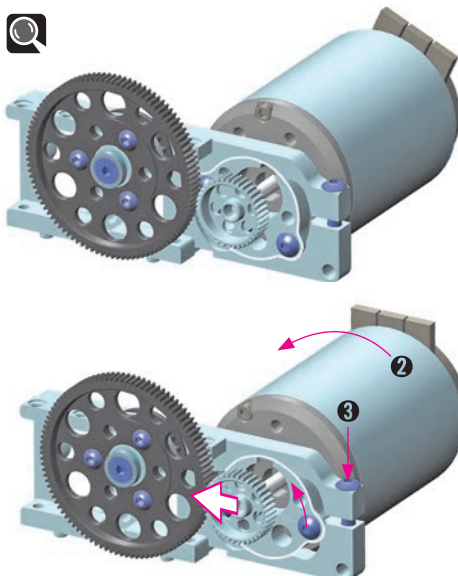

1 Attach the motor to the eccentric motor holder in the indicated orientation. Tighten the mounting screws.

2 Adjust the gear mesh by rotating the eccentric motor holder.

3 Tighten the damp screw.

2 Adjust the motor so the pinion meshes with the spur gear properly. Make sure the gear mesh is NOT too tight. There should be a small amount of play between the teeth of the pinion gear and the spur gear.



7. FINAL ASSEMBLY

1x 903308
SFH M3x8

VIDEO TECH TIP

WEIGHT BALANCE

ELECTRONICS INSTALLATION

Receiver (NOT INCLUDED)

Speed Controller (NOT INCLUDED)

Double-sided Tape HUDY #107875 (NOT INCLUDED)

3x8mm

NOTE: If the antenna tube DOES NOT hold the antenna properly, apply a small drop of the CA glue to the outside end of the antenna tube while inserting it into the holder. Make sure NOT to apply glue to the inside of the antenna tube, or the antenna wire will get permanently stuck.

Feed the receiver wire into the antenna tube.

OPTION

FORWARD ALU FAN MOUNT ALTERNATIVE

There are two options how to mount the fan mount depending of the style and size of the fan. Either in front or behind the motor. If you are using HUDY fan, we recommend to use FORWARD mount as it keeps the weight of the car as much in front as possible.

#306410 ALU FAN MOUNT

#902318 SH M3x18

#333074 ALU MOUNT 3x6x10.5mm (2)

10.5mm

#293101 HUDY ALU RC FAN 30mm SIDE MOUNT 2 HOLE

#293104 HUDY ALU RC FAN 40MM - BOTTOM/SIDE MOUNT 2 HOLE

#293110 HUDY BRUSHLESS RC FAN 30mm WITH EXTERNAL SOLDERING TABS

#293112 HUDY BRUSHLESS RC FAN 30mm WITH INTERNAL SOLDERING TABS

#293113 HUDY BRUSHLESS RC FAN 40mm WITH INTERNAL SOLDERING TABS

REARWARD ALU FAN MOUNT ALTERNATIVE

#306410 ALU FAN MOUNT

#293101 HUDY ALU RC FAN 30mm SIDE MOUNT 2 HOLE

#293104 HUDY ALU RC FAN 40MM - BOTTOM/SIDE MOUNT 2 HOLE

#293110 HUDY BRUSHLESS RC FAN 30mm WITH EXTERNAL SOLDERING TABS

#293112 HUDY BRUSHLESS RC FAN 30mm WITH INTERNAL SOLDERING TABS

#293113 HUDY BRUSHLESS RC FAN 40mm WITH INTERNAL SOLDERING TABS

2x 901305
SB M3x5

2x 902320
SH M3x20

VIDEO TECH TIP

BATTERY MOUNTING SYSTEM

3x20mm

3x5mm

NOTE ORIENTATION of the battery holder. The holder has two mounting orientation possibilities depending on the battery size.

Please see page 50/step 1

NOTE ORIENTATION

To ensure correct functioning of the battery holder, DO NOT overtighten the screw; the holder must be able to move.

HEIGHT ADJUSTMENT
1 turn = 0.5mm

7. FINAL ASSEMBLY

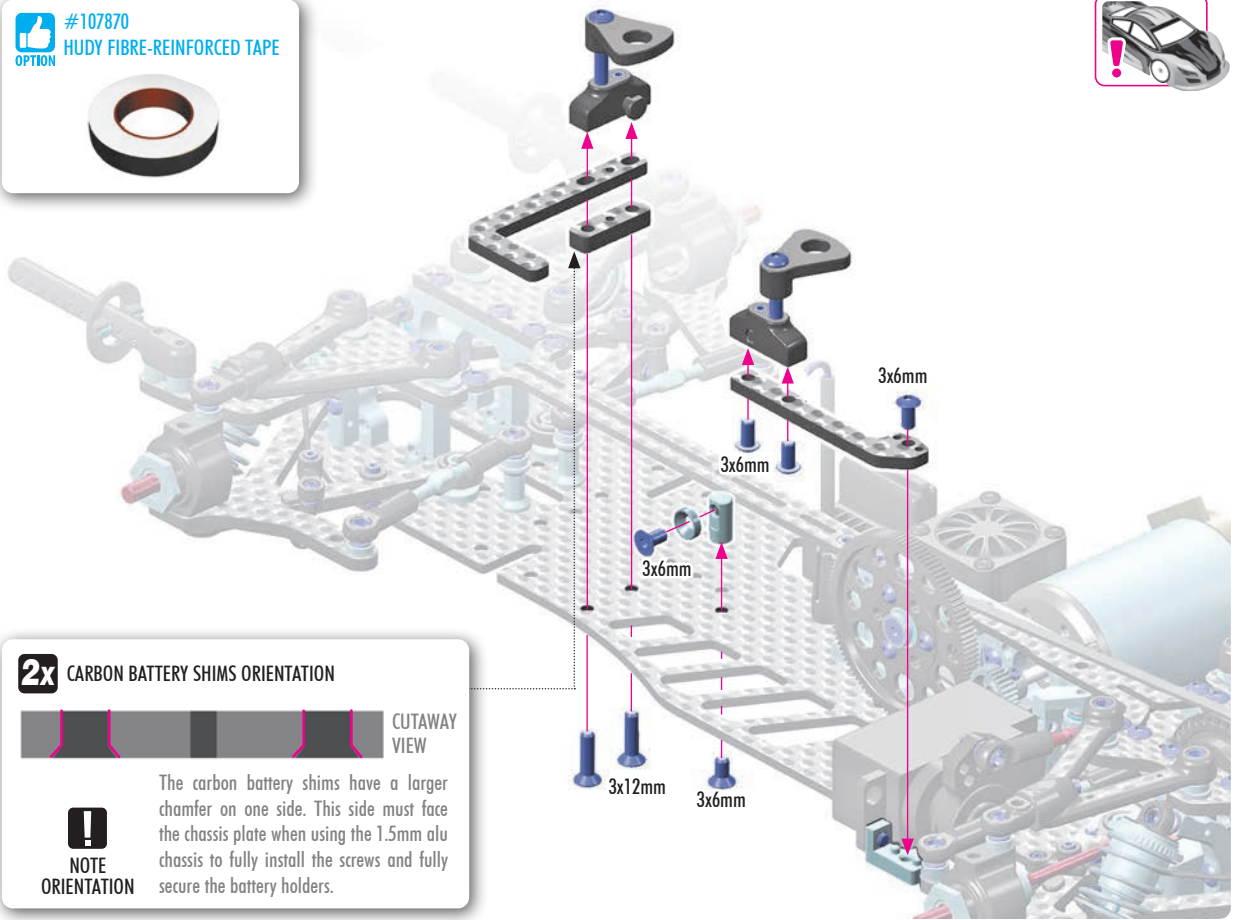

NOTE ORIENTATION
The carbon battery shims have a larger chamfer on one side. This side must face the chassis plate when using the 1.5mm alu chassis to fully install the screws and fully secure the battery holders.



VIDEO TECH TIP



WEIGHT BALANCE

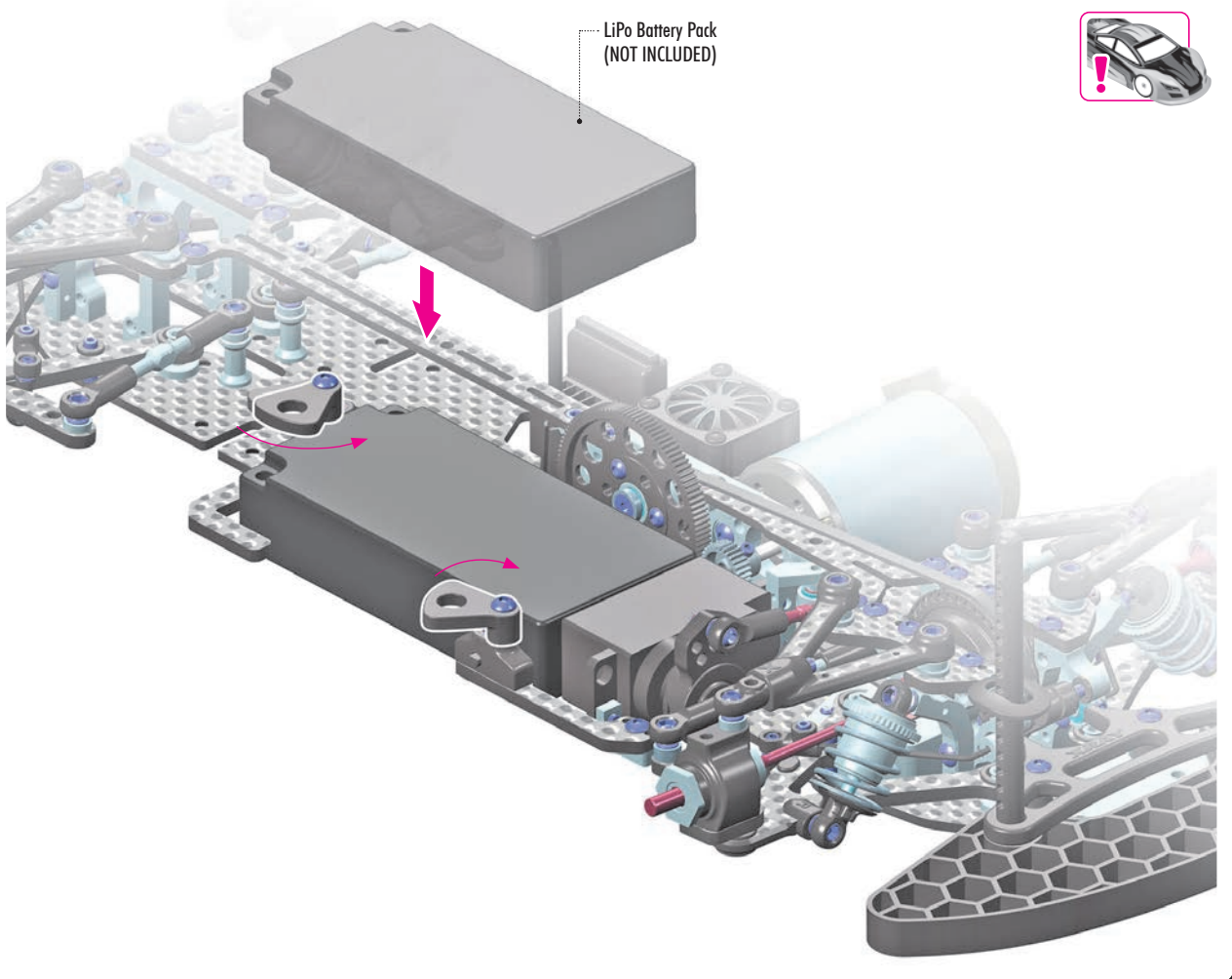

VIDEO TECH TIP



BATTERY MOUNTING SYSTEM

7. FINAL ASSEMBLY

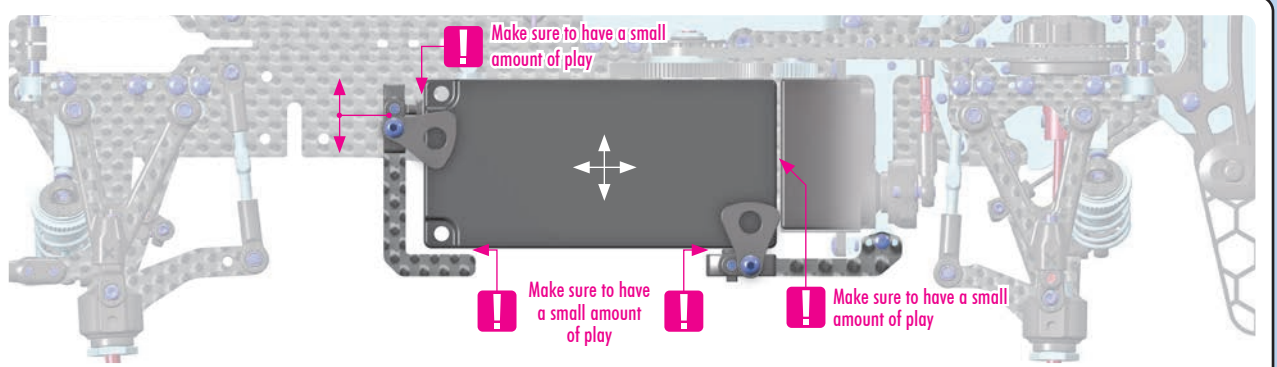

BATTERY BACKSTOP

The new adjustable battery backstop system secures the battery in the car in a tweak-free, non-fixed manner to help improve traction and makes it more stable and easier to drive.

It is very important that battery has a very small amount of play in all directions so it does NOT tweak the car, but the play cannot be too much otherwise the battery may fall out in crashes.

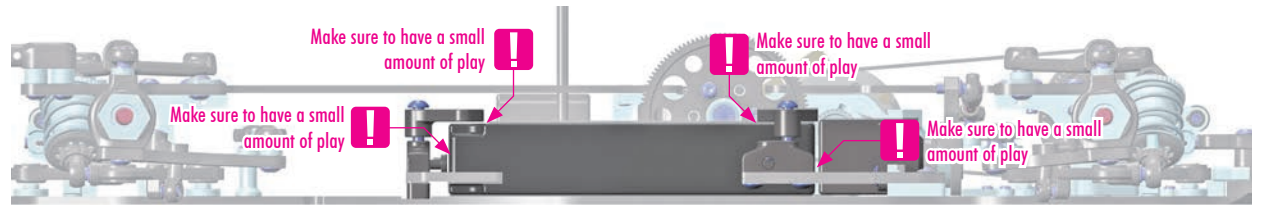

Due to different battery sizes used on carpet and asphalt, there are multiple battery mounting possibilities.

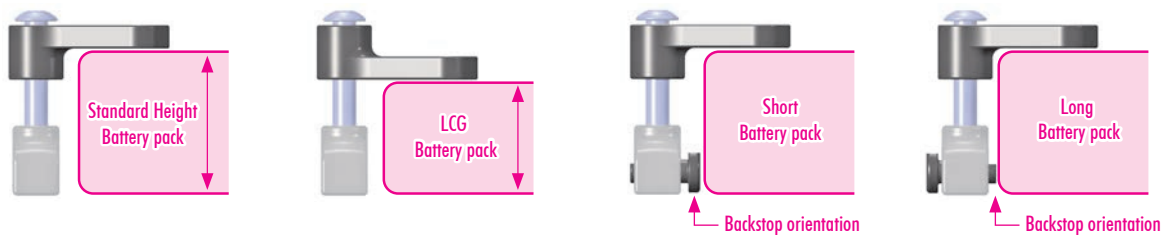

4x 960240 N M4

OPTION	ALU NUT M4 - SERRATED FLANGE		
#296541-B	BLUE	OPTION	
#296541-K	BLACK	OPTION	
#296541-O	ORANGE	OPTION	
#296541-V	VIOLET	OPTION	

OPTION	TITANIUM NUT M4 - SERRATED FLANGE		
#296542	SILVER	OPTION	
#296542-K	BLACK	OPTION	
#296542-B	BLUE	OPTION	
#296542-G	GREEN	OPTION	
#296542-Y	GOLD	OPTION	
#296542-V	VIOLET	OPTION	
#296542-C	RAINBOW	OPTION	

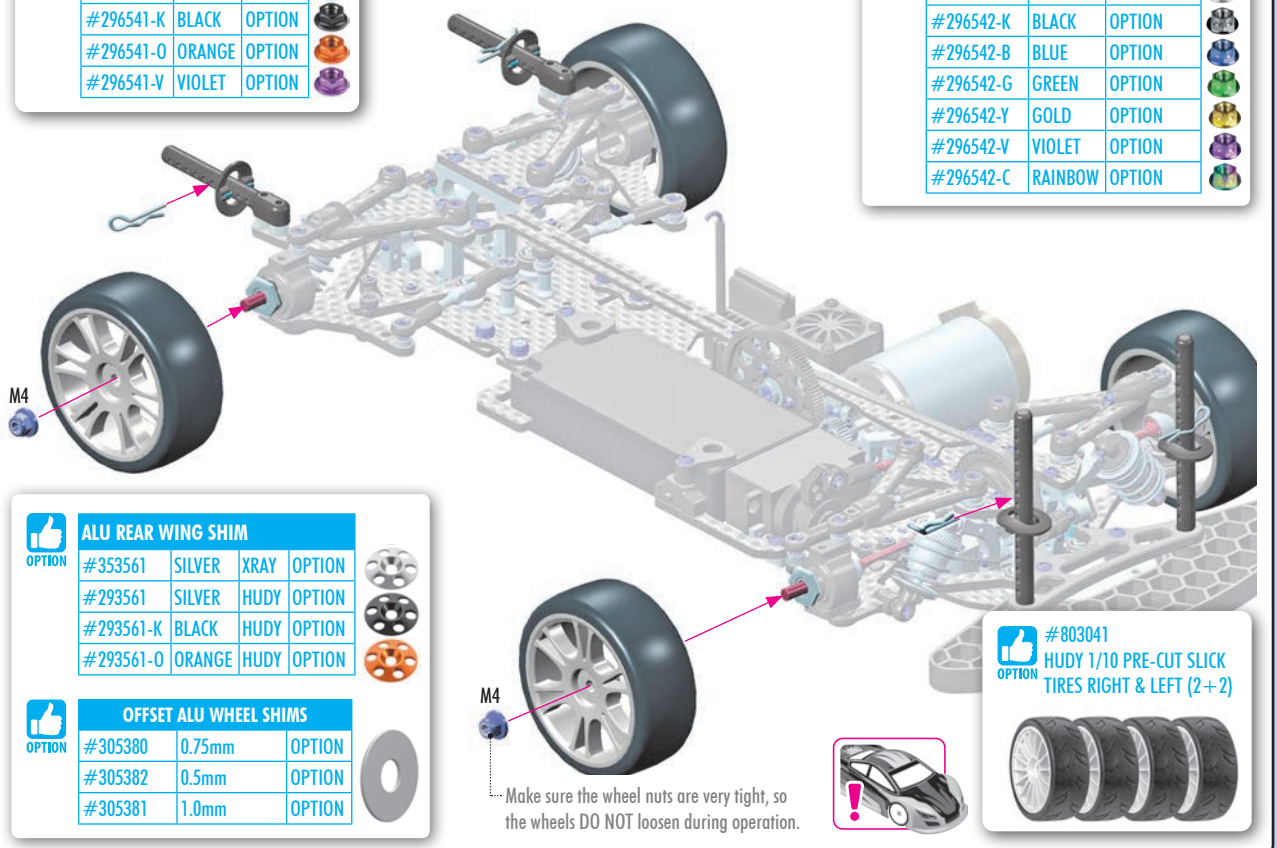

OPTION	ALU REAR WING SHIM			
#353561	SILVER	XRAY	OPTION	
#293561	SILVER	HUDY	OPTION	
#293561-K	BLACK	HUDY	OPTION	
#293561-O	ORANGE	HUDY	OPTION	

OPTION	OFFSET ALU WHEEL SHIMS		
#305380	0.75mm	OPTION	
#305382	0.5mm	OPTION	
#305381	1.0mm	OPTION	



VIDEO TECH TIP



TRACK WIDTH (OFFSET)



DOWNSTOP & RIDE HEIGHT

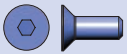

4x 903308
SFH M3x8



4x 960030
NUT M3



4x 971030
O 3x1.5

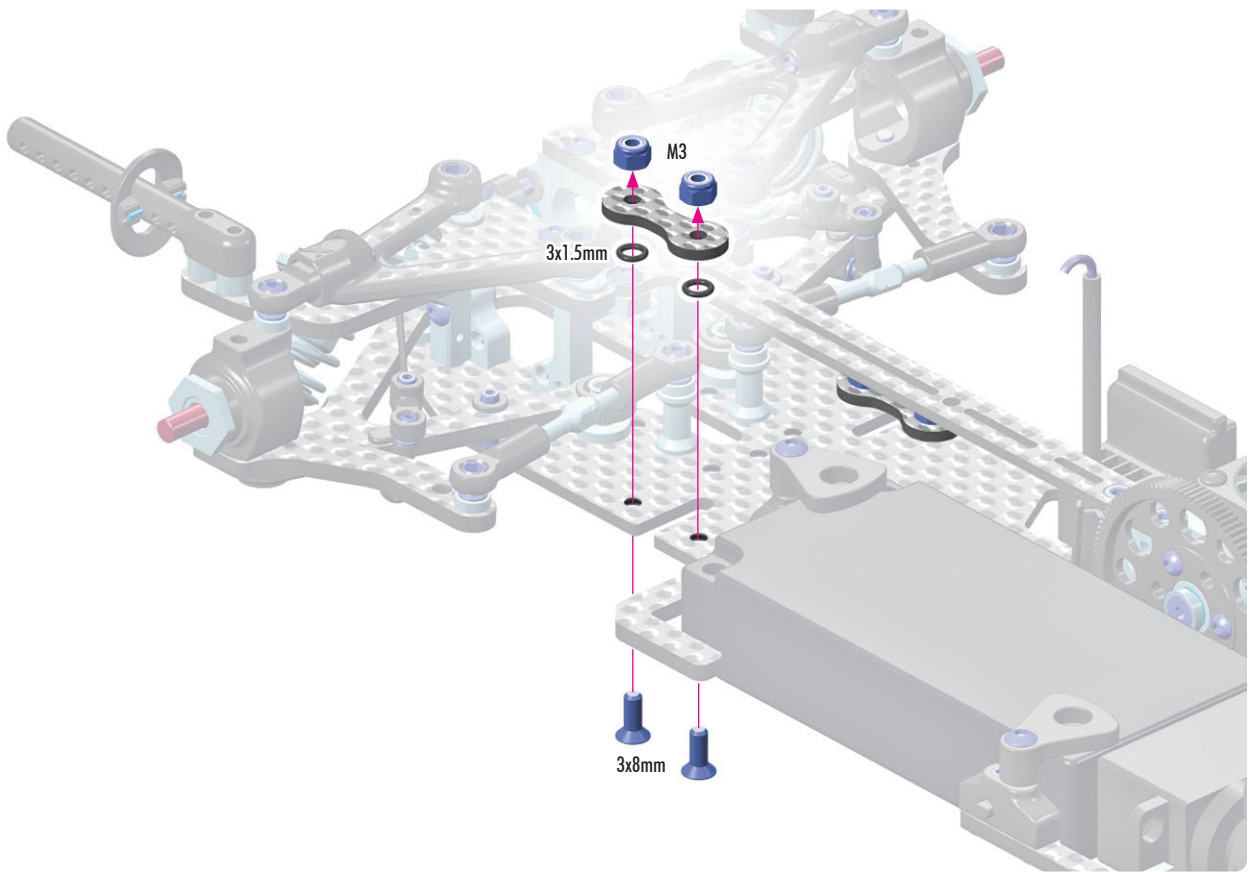

REAR CHASSIS FLEX ADJUSTMENT

The new feature of X4F`27 is possibility to adjust the flex of the rear part of the chassis which has great effect on car handling in various conditions.

SOFT - NO BRACE

When the brace is NOT installed, the car will have maximum steering and rotation. However, the car will be less stable and more difficult to drive. Recommended for medium traction and for small, technical tracks.

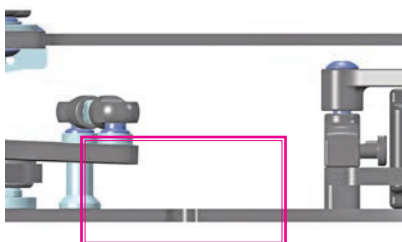
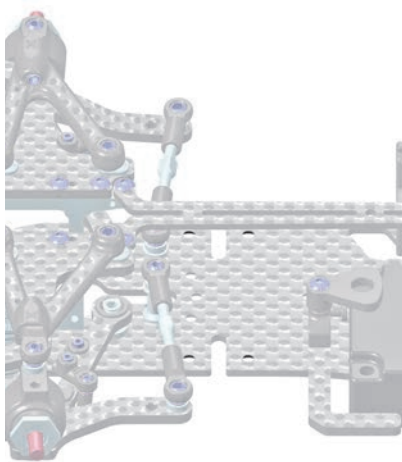

MEDIUM

Install O-rings between the brace and chassis. This improves rotation and mid-corner steering. Recommended for small, medium tracks in medium and high traction.

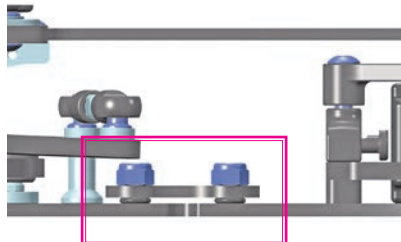
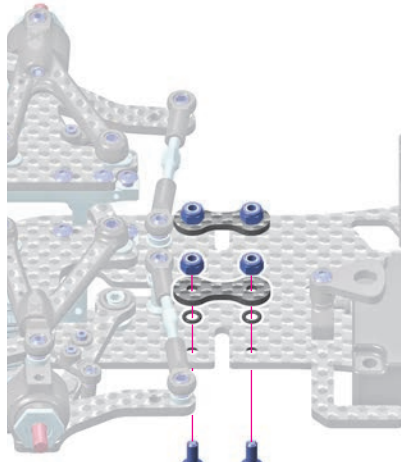

STIFF INITIAL SETTING

Makes the car easier to drive and gives maximum stability. Recommended for all conditions and types of track as a starting point.

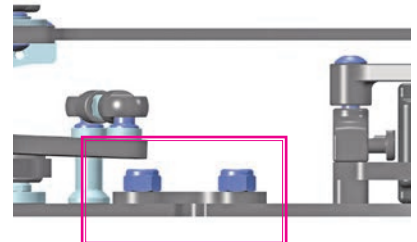
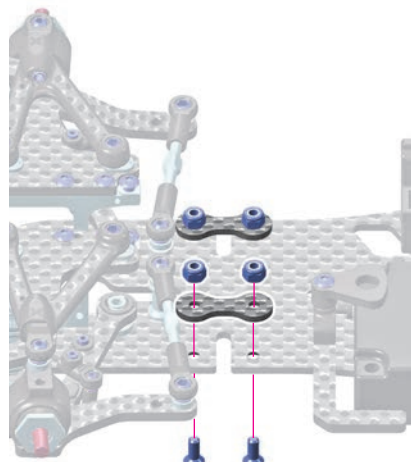

 Do NOT overtighten, as this may deform the O-ring and reduce its intended flex characteristics.



BODY STOP SYSTEM

The X4F features an adjustable front body upstop system incorporated into the new upper arm to prevent the body shell from bottoming out and hitting the ground during cornering. When the system is set correctly, it allows the body to be run lower without dragging on the ground to improve aerodynamic efficiency.



BODY STOP ALTERNATIVE
with screw and ball joint

(#901308 SB M3x8mm / #303457 Ball Joint)



BODY STOP ALTERNATIVE
with screw

(#902316 SH M3x16mm)

(NOT INCLUDED)

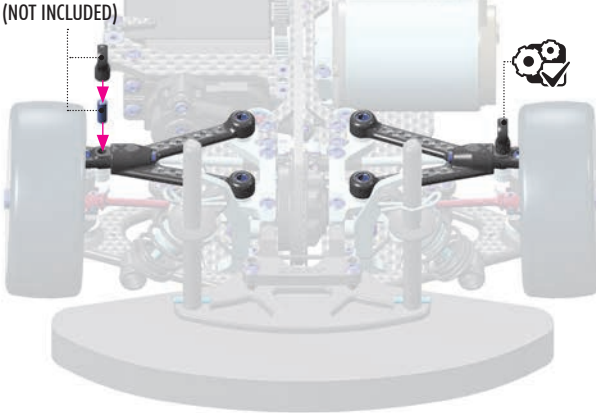

(NOT INCLUDED)

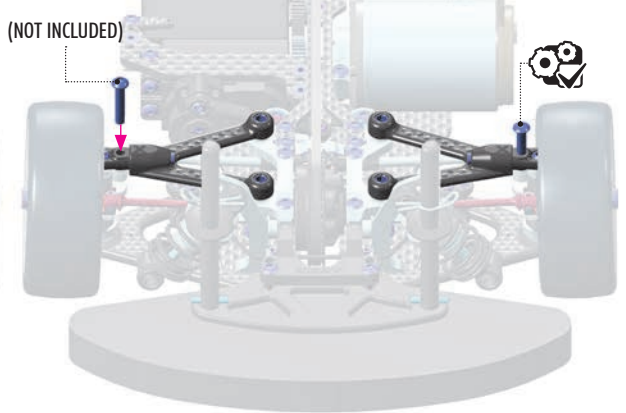

▶ VIDEO TECH TIP



REAR BODY POST MOUNTING

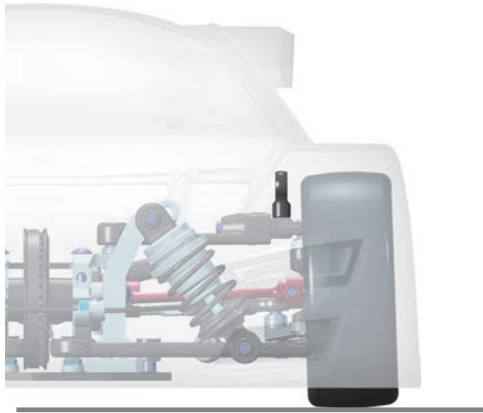

#301348 X4F HORIZONTAL BODY POST MOUNTING GAUGE

Horizontal Body Post Mounting Gauge is special tool designed for X4F that helps to mark the horizontal rear body mounts position on the body shell for a perfect fit on the car and featuring two special scales to check and adjust the proper position of the body. The first scale is used to adjust the rear part of the body and the second scale is used to check the body height around the car. Fits all popular body shells.



▶ VIDEO TECH TIP



CHASSIS TWEAK

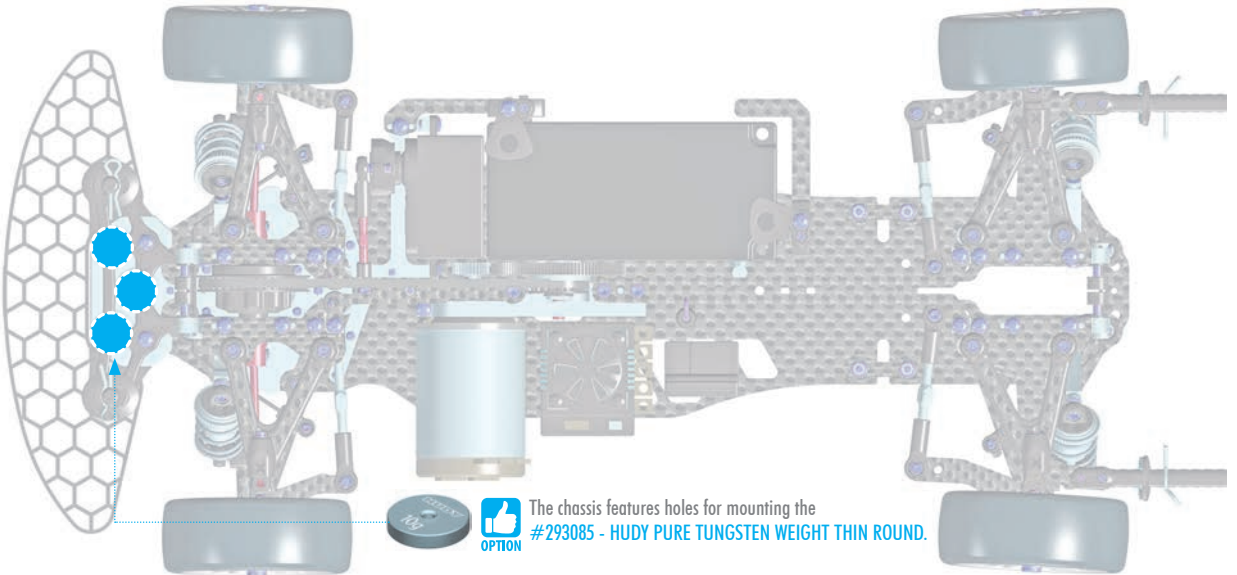

The chassis features holes for mounting the **#293085 - HUDY PURE TUNGSTEN WEIGHT THIN ROUND**.



#326181 STAINLESS STEEL BATTERY WEIGHT 35g



#293083 HUDY PURE TUNGSTEN WEIGHT 15g



#293085 HUDY PURE TUNGSTEN WEIGHT THIN ROUND WITH M3 - 10g



#293081 HUDY PURE TUNGSTEN WEIGHT 5g



#293082 HUDY PURE TUNGSTEN WEIGHT 10g



UPPER ARM LINKS ADJUSTMENT

! The images are for illustrative purposes only (X4). The theory and textual information correspond to XF4'27.

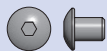

2x 902304
SH M3x4

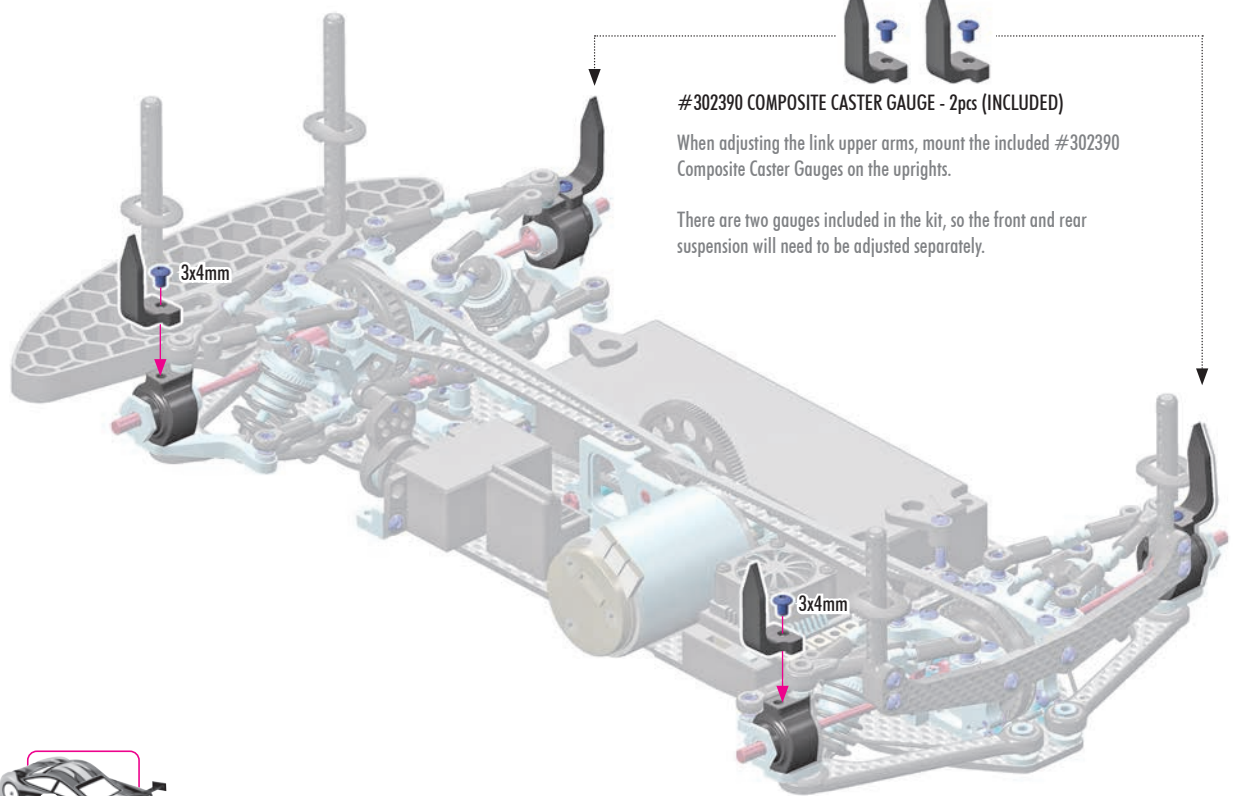

#302390 COMPOSITE CASTER GAUGE - 2pcs (INCLUDED)

When adjusting the link upper arms, mount the included #302390 Composite Caster Gauges on the uprights.

There are two gauges included in the kit, so the front and rear suspension will need to be adjusted separately.



#109301
HUDY SET-UP STATION FOR 1/10 TOURING CARS

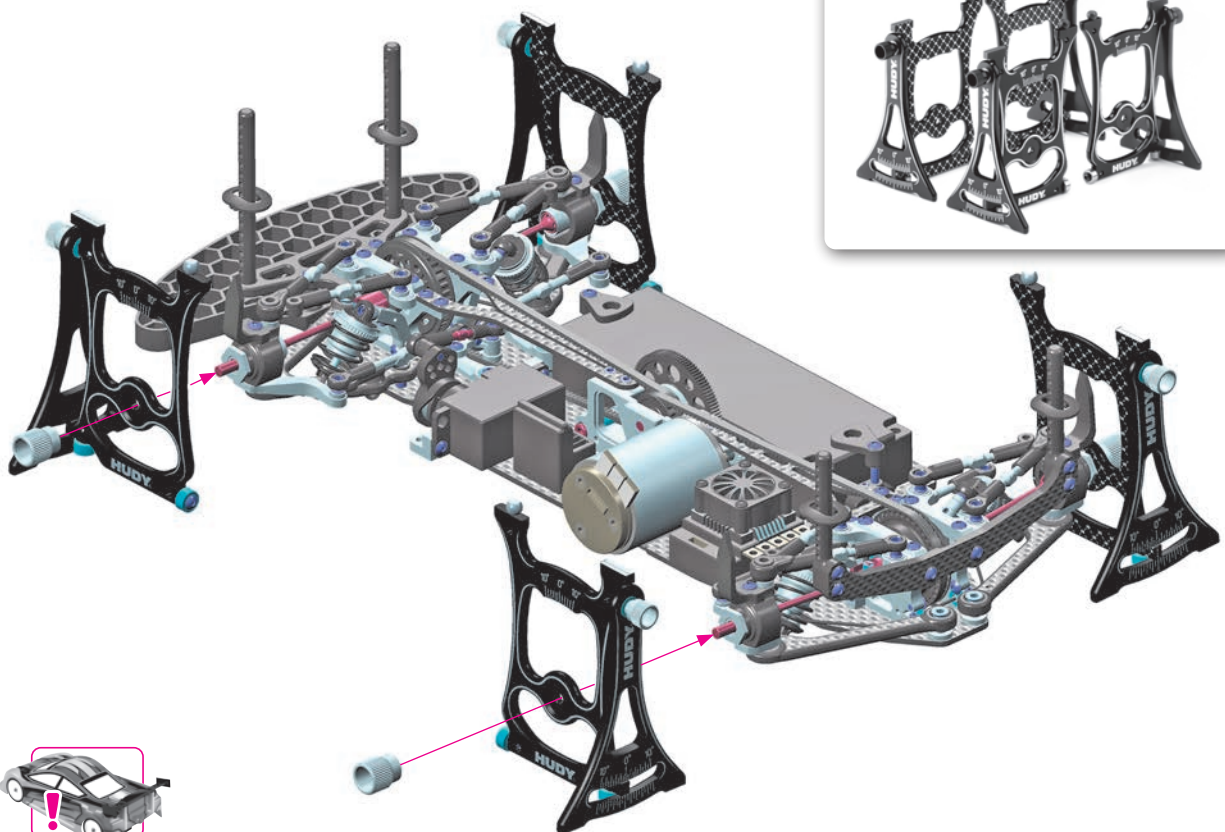

UPPER ARM LINKS ADJUSTMENT



VIDEO TECH TIP



UPPER LINKS
ADJUSTMENT

Setting the upper link system caster and camber requires extra attention. It is recommended to start with the kit upper arm lengths and then fine tune from that position.

To adjust caster while retaining the same camber setting, both camber and caster links will be adjusted by equal but opposite amounts. For example, to increase front suspension caster, the caster link is shortened and the camber link is lengthened by the same value.

Utilize the XRAY Composite Caster Gauges (#302390) to fine tune and verify any caster adjustments.

Make sure that all ball cups are straight and aligned over the ball studs after making adjustments to ensure free movement of the upper link arms, and prevent binding during suspension movement.

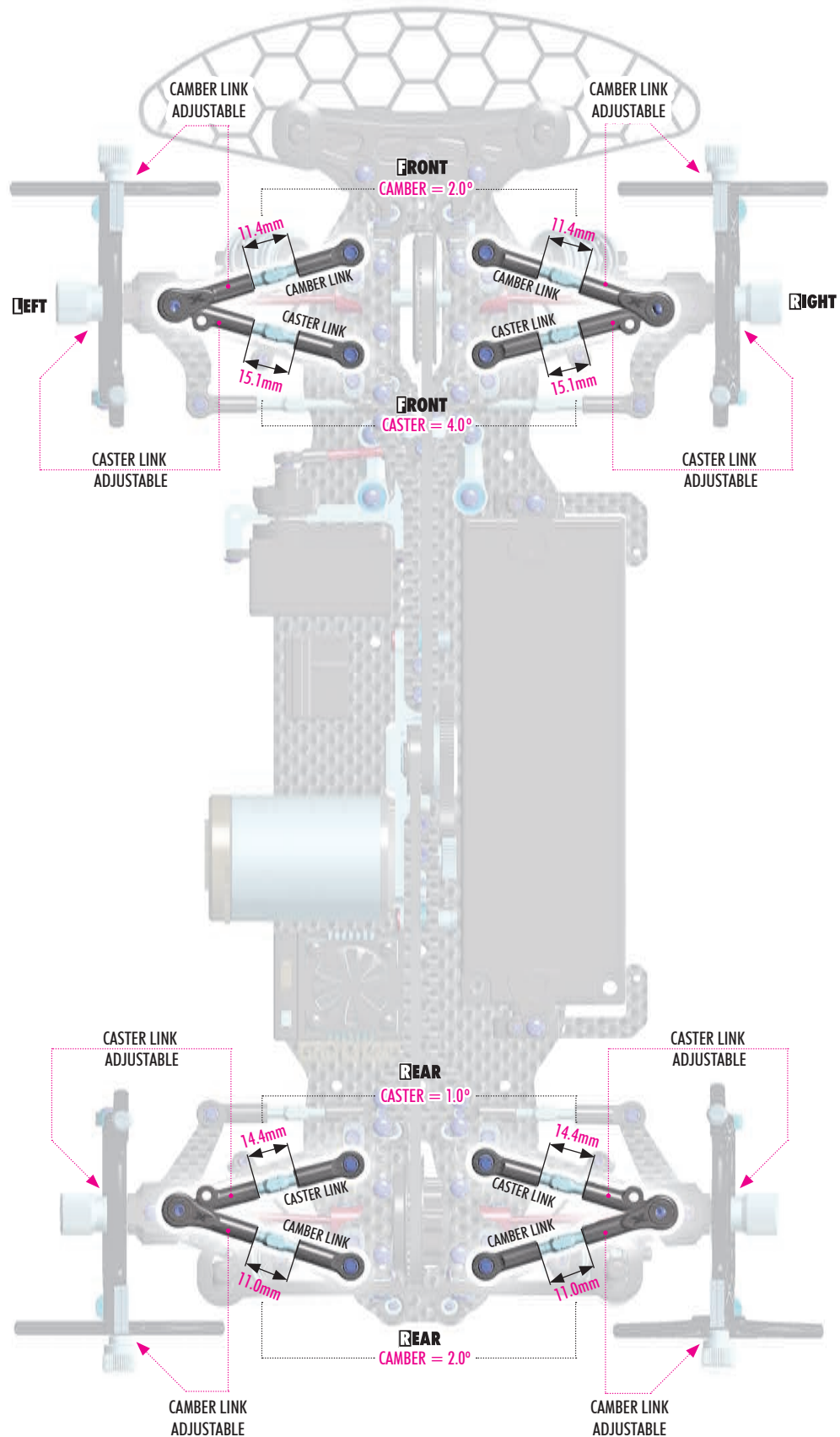

UPPER ARM LINKS ADJUSTMENT



CASTER ADJUSTMENT

When changing caster, it is necessary to check both caster and camber values each time the upper links are adjusted.

CAMBER ADJUSTMENT

Adjustment of caster will directly affect camber and vice-versa. After any adjustment, always check the other values to ensure proper geometry.

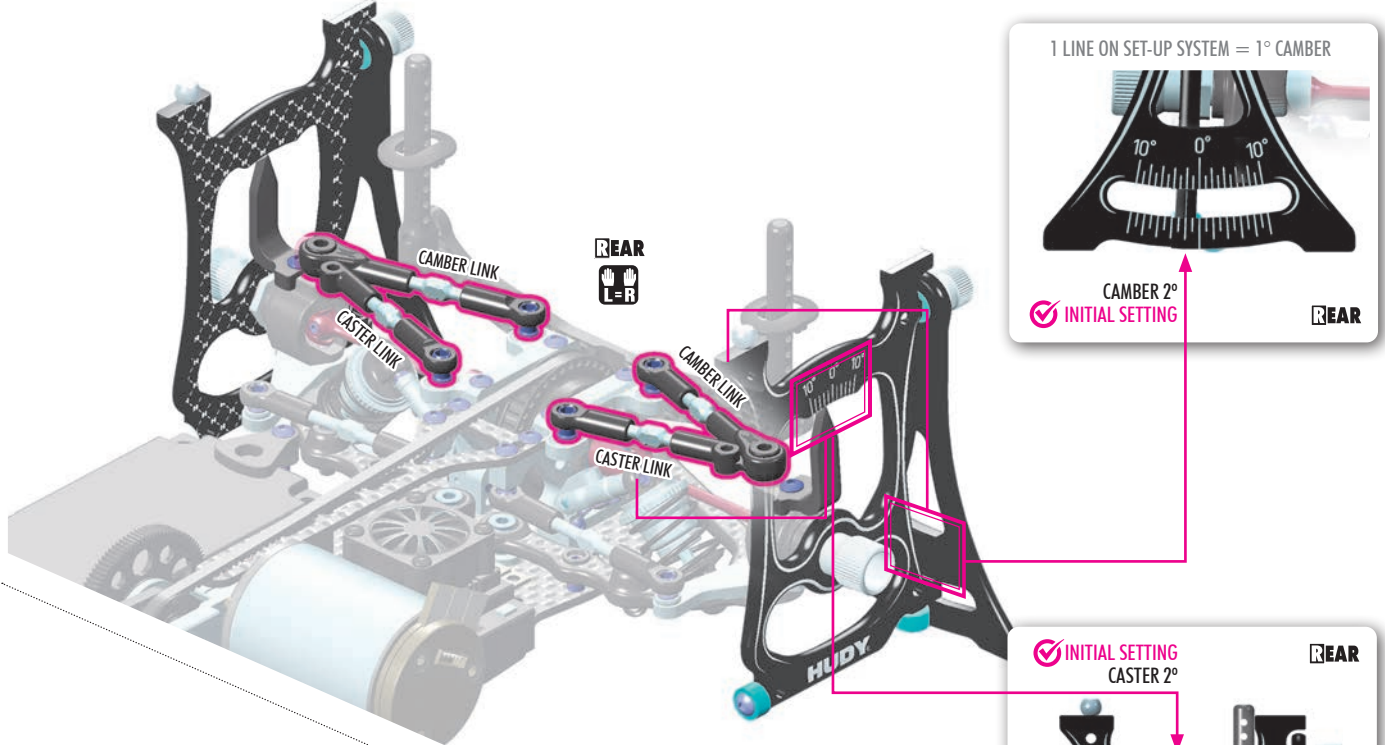

IMPORTANT

Adjustment of caster will directly affect camber and vice-versa. After any adjustment, always check the other values.

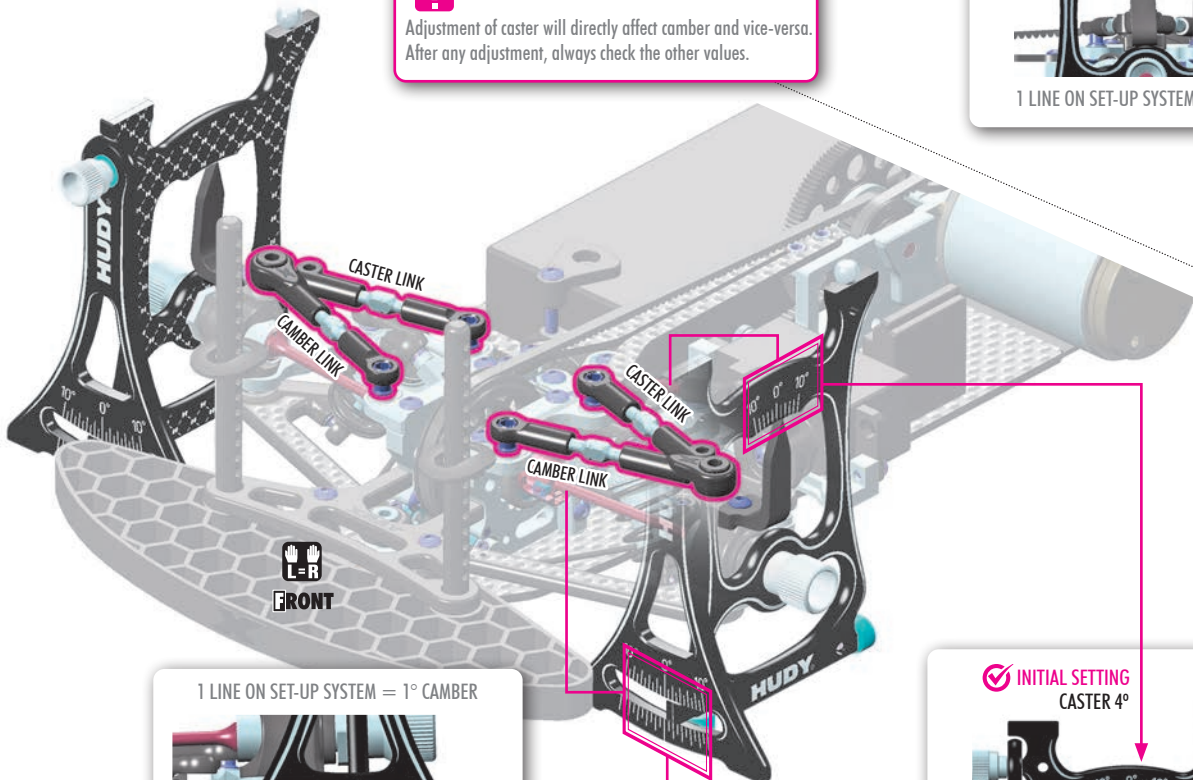

EXCLUSIVE PROFESSIONAL

HUDY

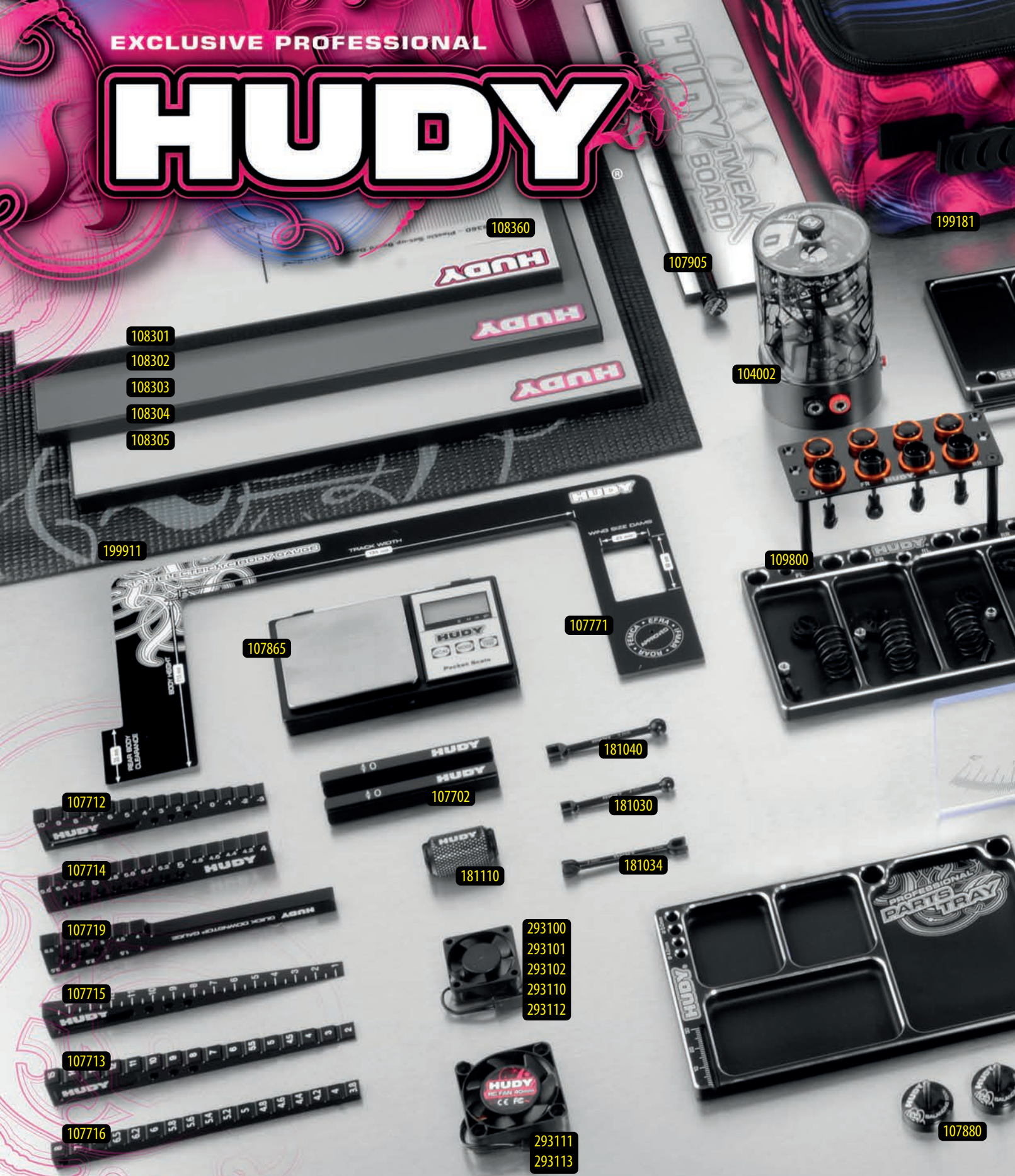

104002 HUDY AIR VAC - VACUUM PUMP - ON-ROAD
 106260 HUDY TIRE ADDITIVE - TIRE GRIPPER - 50ML - V2
 107090 HUDY BEARING CHECKING TOOL
 107601 LIMITED EDITION - REAMER FOR BODY 0-9MM + COVER - SMALL
 107643 LIMITED EDITION - ARM REAMER # 3.0MM
 107702 CHASSIS DROOP GAUGE SUPPORT BLOCKS FOR 1/10 (2)
 107712 CHASSIS DROOP GAUGE -3.0-10MM FOR 1/10 CARS (10MM)
 107713 CHASSIS RIDE HEIGHT GAUGE STEPPED 2.0-15.0MM
 107714 ULTRA-FINE CHASSIS DROOP GAUGE 4.0-6.6MM
 107715 CHASSIS RIDE HEIGHT GAUGE 1.0-15.0MM (BEVELED)
 107716 ULTRA-FINE CHASSIS RIDE HEIGHT GAUGE 3.8-8.0MM
 107719 QUICK DOWNSTOP GAUGE TOOL 1.0-6.5MM
 107720 CHASSIS RIDE HEIGHT GAUGE 30-17MM FOR 1/8 & 1/10 OFF-ROAD
 107750 HUDY CARBON QUICK CAMBER GAUGE 1.5°, 2°, 2.5° FOR 1/10 TC

107771 HUDY BODY GAUGE 1/10 ELECTRIC TOURING CARS
 107855 HUDY PIT LED
 107865 HUDY PROFESSIONAL DIGITAL POCKET SCALE 300G/0.01G
 107870 HUDY FIBRE-REINFORCED TAPE - BLACK
 107875 HUDY ULTRA DOUBLE-SIDED TAPE
 107880 CHASSIS BALANCING TOOL (2)
 107904 HUDY QUICK-TWEAK STATION 1/10 & 1/12 ON-ROAD
 107905 HUDY TWEAK BOARD SET
 108150 HUDY 1/10 TOURING CAR STAND - V3
 108190 HUDY ALU PARTS TRAY 160x100MM
 108192 HUDY ALU PARTS TRAY NARROW 215x50MM
 108193 HUDY ALU PARTS TRAY LARGE 215x100MM
 108301 FLAT SET-UP BOARD 1/10 & 1/12 - LIGHTWEIGHT - GREY
 108302 FLAT SET-UP BOARD 1/10 & 1/12 - LIGHTWEIGHT - SILVER GREY

108303 FLAT SET-UP BOARD 1/10 & 1/12 - LIGHTWEIGHT - RED
 108304 FLAT SET-UP BOARD 1/10 & 1/12 - LIGHTWEIGHT - BLACK
 108305 FLAT SET-UP BOARD 1/10 & 1/12 - LIGHTWEIGHT - WHITE
 108360 PLASTIC SET-UP BOARD DECAL
 109301 HUDY SET-UP STATION FOR 1/10
 109360 ALU NUT FOR 1/10 TOURING S
 109370 ALU SET-UP WHEEL FOR 1/10 F
 109800 HUDY ALU TRAY FOR ON-ROAD
 109840 HUDY ALU TRAY FOR 1/10 OFF
 109860 HUDY ALU TRAY FOR SET-UP S
 109880 HUDY ALU TRAY FOR ACCESSO
 111545 LIMITED EDITION - ALLEN WRE
 112045 LIMITED EDITION - ALLEN WRE
 113045 LIMITED EDITION - ALLEN WRE

EXCLUSIVE PROFESSIONAL

HUDY

HUDY

199295-H

199290-H

106261

106200

803041

107861

107840

107846

107761

105590

293080

106290

293012

293011

293083

293082

293081

293084

294017~294035

294127~294160

- | | | | |
|--------|---|--------|---|
| 107761 | HUDY ADJUSTABLE CAMBER GAUGE 80MM | 105590 | HUDY WHEEL BALANCING PUTTY |
| 107772 | HUDY PROFESSIONAL 1/10 TC WHEEL ARCH MARKER + WHEEL ADAPTER & NUT | 181090 | HUDY SPECIAL TOOL FOR TURNBUCKLES & NUTS |
| 106210 | HUDY GRAPHITE GREASE | 181091 | HUDY TURNBUCKLE WRENCH 3 & 4MM - V2 |
| 106230 | HUDY BEARING OIL | 803041 | HUDY 1/10 PRE-CUT SLICK TIRES RIGHT & LEFT (2+2) |
| 106200 | HUDY MAGIC CLEANING GUM | 293011 | HUDY STAINLESS STEEL BATTERY WEIGHT 35G |
| 106261 | HUDY TIRE ADDITIVE - TIRE GRIPPER RED - 50ML | 293012 | HUDY STAINLESS STEEL BATTERY WEIGHT FOR NARROW BATTERY PACK 35G |
| 106350 | HUDY PREMIUM SILICONE OIL 500 CST - 50ML | 293080 | LEAD WEIGHTS 4x5G & 4x10G WITH 3M GLUE |
| 107861 | HUDY PROFESSIONAL RACING STOPWATCH XL DISPLAY | 293081 | HUDY PURE TUNGSTEN WEIGHT 5G |
| 106290 | HUDY PROFESSIONAL SOLDER 3M LENGTH | 293082 | HUDY PURE TUNGSTEN WEIGHT 10G |
| 107840 | CLEANING BRUSH LARGE - SOFT | 293083 | HUDY PURE TUNGSTEN WEIGHT 15G |
| 107846 | CLEANING BRUSH SMALL - SOFT | 293084 | PRECISION BALANCING CHASSIS WEIGHT 10G (4) |
| 105520 | WHEEL ADAPTER FOR 1/10 ON-ROAD & 1/10 OFF-ROAD - 12MM | 293311 | CARBON REAR WING SIDE PLATE 0.5MM - 1/10 ELECTRIC (2) |



199280M-H



199296-H



298015



105520

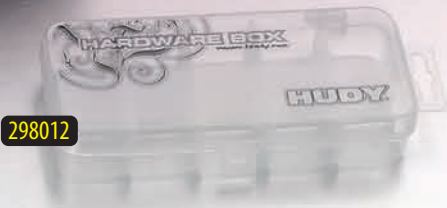

298012



298016



298018

298019



107772

298014



181090



106310~106694



298017



293311



298013



293491~293493

293401~293403

293497~293499

293404~293406

293501~293503

293407~293409



181091



106210



106230



- 293403 ALU CLAMP SERVO HORN - FUTABA, SAVÖX - OFFSET 1-HOLE M3 - 25T
- 293493 ALU SERVO HORN - FUTABA, SAVÖX - OFFSET 1-HOLE M3 - 25T - V2
- 294023 HUDY ALU ULTRA-LIGHT PINION GEAR - HARD COATED - 23T / 48
- 294140 HUDY ALU ULTRA-LIGHT PINION GEAR - HARD COATED - 40T / 64
- 294156 HUDY ALU ULTRA-LIGHT PINION GEAR - HARD COATED - 56T / 64
- 298012 HUDY PARTS BOX - 10-COMPARTMENTS
- 298013 HUDY SPRINGS BOX - 10-COMPARTMENTS
- 298014 HUDY PARTS BOX - 8-COMPARTMENTS
- 298015 HUDY PARTS CASE - 290 x 195MM
- 298016 HUDY TINY HARDWARE BOX - 4-COMPARTMENTS
- 298017 HUDY TINY ONE-PIECE HARDWARE BOX - 8-COMPARTMENTS
- 298018 HUDY TINY HARDWARE BOX - 8-COMPARTMENTS

- 298019 HUDY DIFF BOX - 8-COMPARTMENTS
- 199280M-H HUDY HARD CASE - 140x110x95MM - OIL BAG MEDIUM
- 199290-H HUDY HARD CASE - 235x190x75MM - ACCESSORIES / ENGINE BAG
- 199295-H HUDY HARD CASE - 280x150x85MM - ACCESSORIES BAG LARGE
- 199296-H HUDY HARD CASE - 120x85x46MM - ACCESSORIES / STOP WATCH

For more information about tools, set-up equipment & accessories suitable for your car please visit:

www.hudy.net



www.teamxray.com

XRAY EUROPE

XRAY, K VÝSTAVISKU 6992, 91101 TRENCIN, SLOVAKIA, EUROPE
 PHONE: +421-32-740 11 00, FAX: +421-32-740 11 09, info@teamxray.com

XRAY USA

RC AMERICA, 2030 Century Center Blvd #15, Irving, TX 75062, USA
 PHONE: 214-744-2400, FAX: 214-744-2401, xray@rcamerica.com

