

SET-UP SHEET

X4F'25 SET-UP SHEET VER.1 ©XRAY

XRAY X4F'25

RACE

TRACK

NAME DATE

TRACK TEMP.	QUAL POS.	FINAL POS.	BEST LAP TIME	LAPS	TIME
<input type="text"/>	<input type="text"/>	<input type="text"/>	<input type="text"/> /sec	<input type="text"/>	<input type="text"/>

TRACK

TRACK SURFACE CARPET ASPHALT

TRACK LAYOUT TECHNICAL MIXED FAST

TRACTION LOW MEDIUM HIGH

FRONT TRANSMISSION REAR

GEAR DIFFERENTIAL - OIL /cst

PINION / T SPUR GEAR / T FINAL DRIVE RATIO

FRONT SHOCKS REAR

XRAY SPRINGS

OIL /cst

REBOUND %

4 HOLES 1.1mm 1.1mm 4 HOLES

PSS 1.2mm 1.2mm PSS

SHOCK LENGTH /mm /mm SHOCK LENGTH

THICKNESS/mm **ANTI-ROLL BAR** THICKNESS/mm

TIRES

ADDITIVE

ADDITIVE TIMING

WIPE OFF TIME

TIRE WARMERS

Timing: Temp.:

FRONT LEFT FRONT RIGHT REAR LEFT REAR RIGHT

TREATED AREA

TOTAL WEIGHT /g WEIGHT BALANCE FRONT % REAR %

MOTOR TIMING RPM LIMIT

ESC BATTERIES

BODY WING

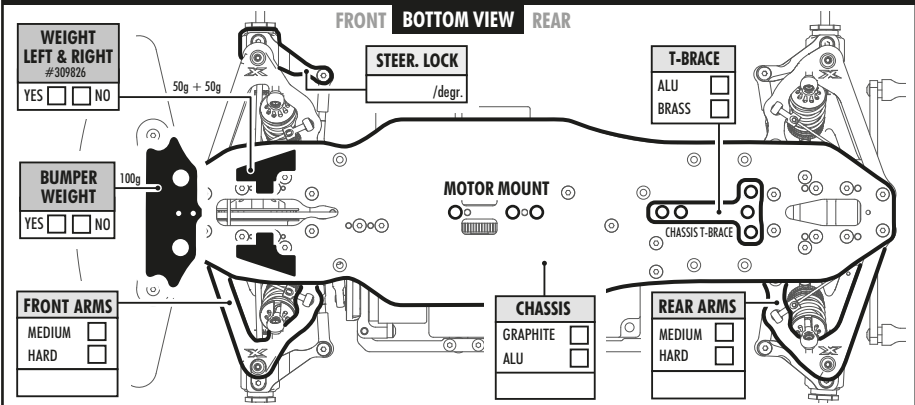
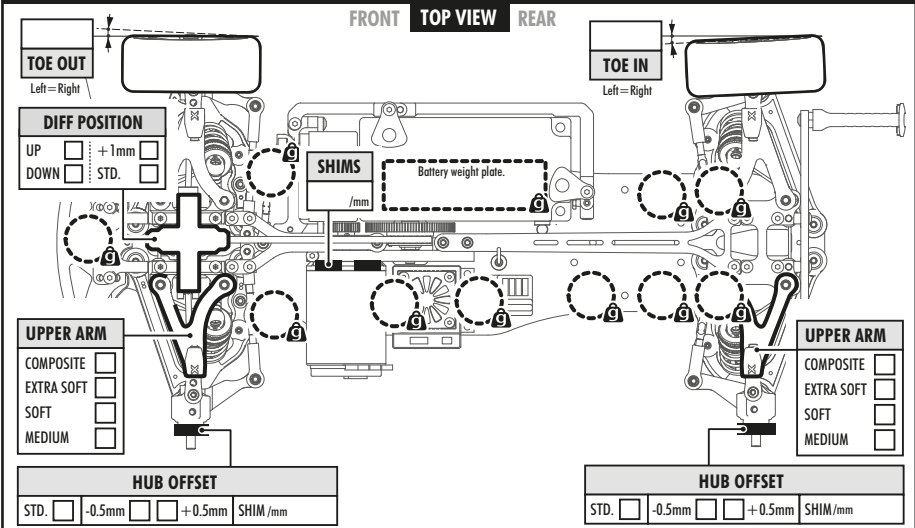
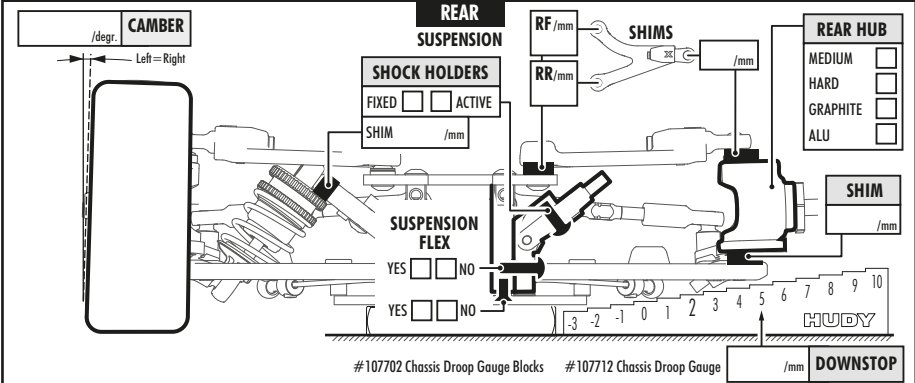
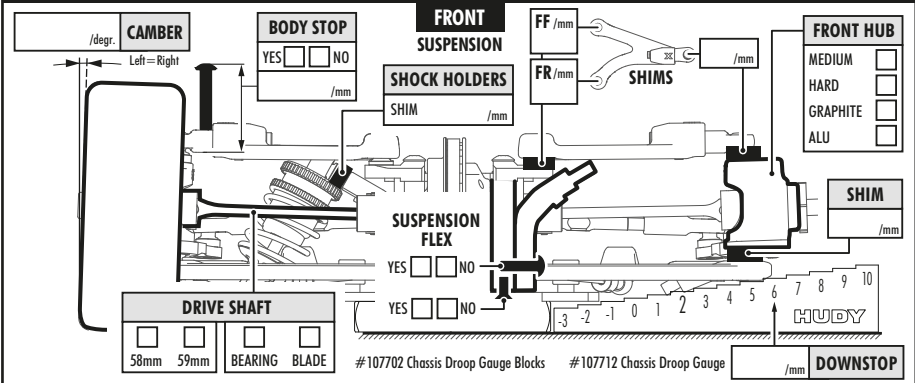
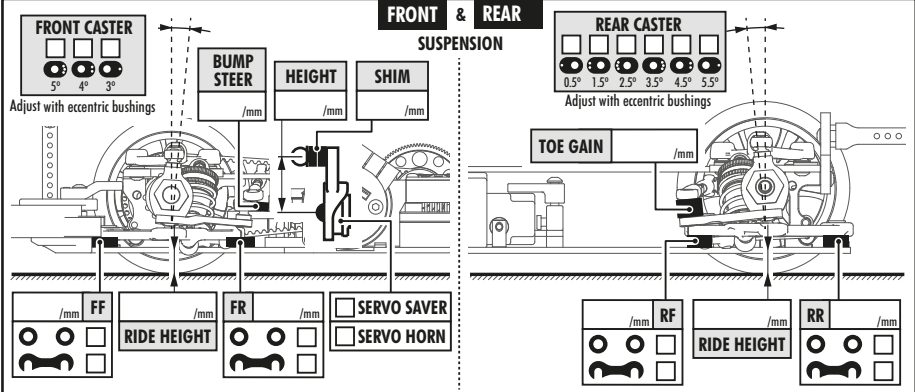
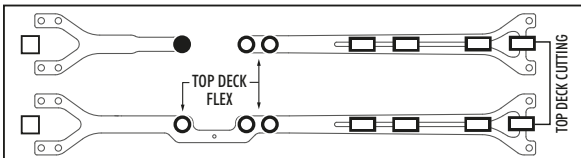
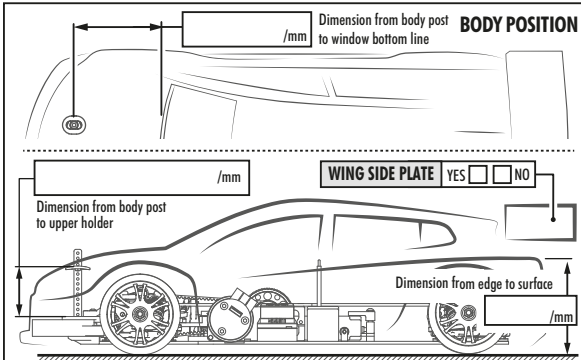

COMMENTS