

SETUP SHEET

RACE					
TRACK					
DRIVER			DATE		
QUAL POSITION	FINAL POSITION	BEST LAP TIME	LAPS	TIME	
		/sec		/	

TRACK					
COMPOSITION	<input type="checkbox"/> CARPET		<input type="checkbox"/> ASPHALT		
LAYOUT	<input type="checkbox"/> TECHNICAL	<input type="checkbox"/> MIXED	<input type="checkbox"/> FAST		
TRACTION	<input type="checkbox"/> LOW	<input type="checkbox"/>	<input type="checkbox"/>	<input type="checkbox"/>	<input type="checkbox"/> HIGH

FRONT	TRANSMISSION	REAR
DIFF OIL	<input type="checkbox"/> FRONT SOLID AXLE	DIFF OIL
UP <input type="checkbox"/>	SOLID & DIFF POSITION	DOWN <input type="checkbox"/>
PINION	SPUR GEAR	F. DRIVE RATIO

FRONT	SHOCKS	REAR
	XRAY SPRINGS	
	OIL /Cst	
	REBOUND %	
<input type="checkbox"/>		<input type="checkbox"/>
LENGTH		LENGTH

THICKNESS/mm	ANTI-ROLL BAR	THICKNESS/mm
--------------	---------------	--------------

TYRES			
ADDITIVE			
ADDITIVE TIMING			
WIPE OFF TIME			
TYRE WARMERS	Timing:	Temp.:	Timing:

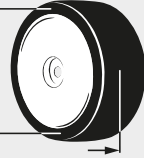

TOTAL WEIGHT	/g	WEIGHT BALANCE	FRONT	%	REAR	%
MOTOR		TIMING				
ESC		BATTERY				
BODY		WING				

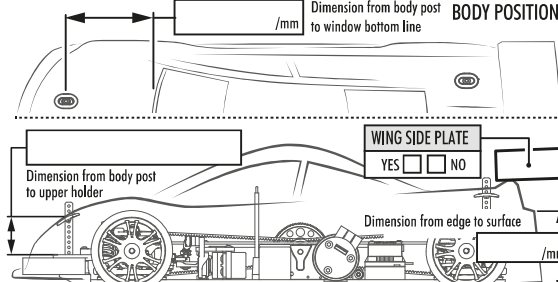

WING SIDE PLATE	YES <input type="checkbox"/>	NO <input type="checkbox"/>
-----------------	------------------------------	-----------------------------

WAVE BRACE	GF <input type="checkbox"/>	1.6 <input type="checkbox"/>	2.0 <input type="checkbox"/>	2.0 <input type="checkbox"/>	1.6 <input type="checkbox"/>	GF <input type="checkbox"/>
TOP DECK	SCREWS					
BULKHEADS	SHIMS					
NONE <input type="checkbox"/>	Rear used in front					
	2.0 <input type="checkbox"/>					
	1.6 <input type="checkbox"/>					
	#301092					
	NONE <input type="checkbox"/>					
	BEARING <input type="checkbox"/>					

