

SET-UP SHEET

XRAY X12'16

RACE	US Indoor Champs
TRACK	Holiday Inn Ballroom

NAME	Max Kuenning
CITY / COUNTRY	Albuquerque USA
CONTACT	maxkuenning@mac.com
DATE	02/12/2015

TEMPERATURE AIR	76	TEMPERATURE TRACK	
-----------------	----	-------------------	--

QUAL POSITION	FINAL POSITION	BEST LAP TIME	RACE LENGTH
4	8.2	5 /sec	8 /min

TRACK	
TRACK SURFACE	<input checked="" type="checkbox"/> CARPET <input type="checkbox"/> ASPHALT
TRACK LAYOUT	<input checked="" type="checkbox"/> TECHNICAL <input type="checkbox"/> MIXED <input type="checkbox"/> FAST
TRACTION	<input type="checkbox"/> LOW <input type="checkbox"/> MEDIUM <input checked="" type="checkbox"/> HIGH

CENTER SHOCK ABSORBER			
SPRING	Black	OIL /cSt	500
		REBOUND %	0
SIDE LINKAGES	<input checked="" type="checkbox"/>	OIL /cSt	20000
SIDE SHOCK	<input type="checkbox"/>	OIL /cSt	

FRONT	TIRES	REAR	
ULTI JM	TIRES TYPE	ULTI XM	
40	DIAMETER /mm	40.5	
SXT	ADDITIVE	SXT	
5 Minutes	ADDITIVE TIMING	15 Minutes	
FRONT LEFT	FRONT RIGHT	REAR LEFT	REAR RIGHT
ADDITIVE TREATED AREA			

TRANSMISSION	
DIFF SETTING	
<input type="checkbox"/> LOOSE	<input type="checkbox"/> MEDIUM
<input type="checkbox"/> TIGHT	<input checked="" type="checkbox"/>

GEARING			
PINION / T	25	SPUR GEAR/T	94
FINAL DRIVE RATIO	3.76	ROLLOUT	33.822

ELECTRONICS	
MOTOR	Trinity Revtech 24k 3.5
SPEEDO	Tekin RSX
BATTERIES	Trinity White Carbon HC

BODY	
TYPE	PROTOform AMR PLW

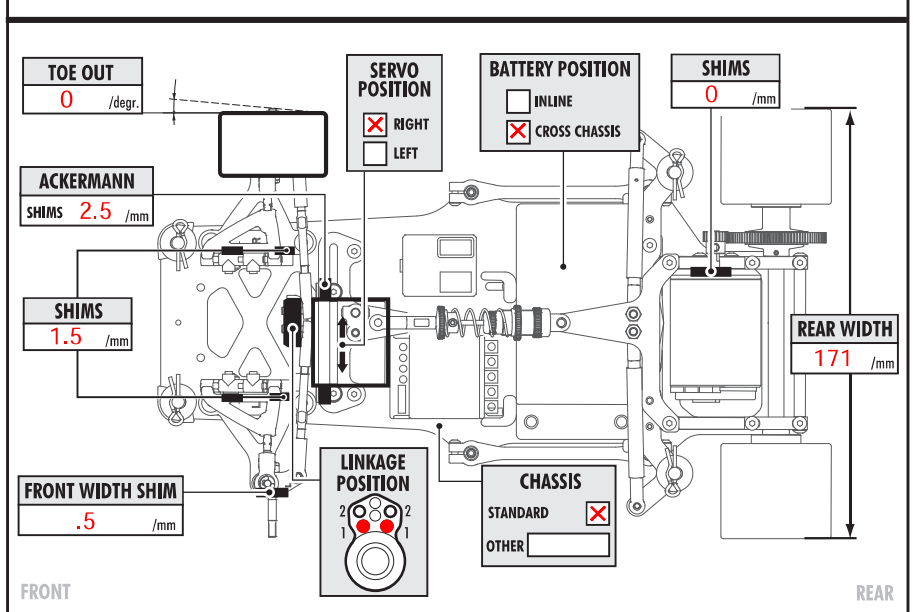
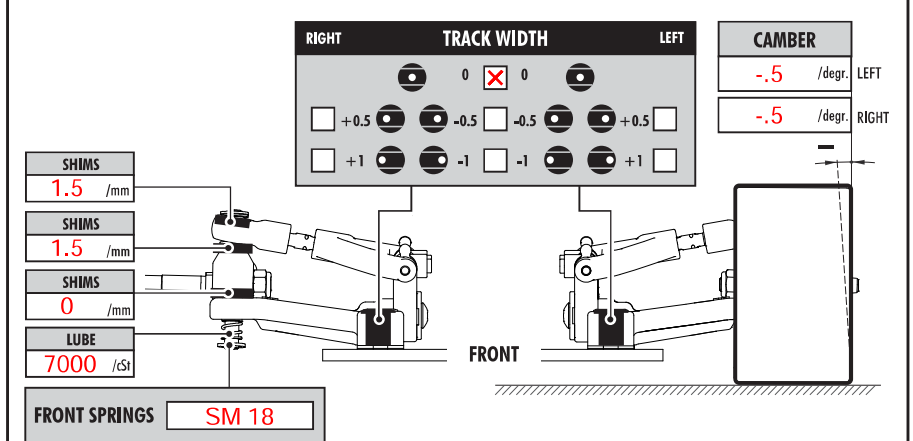
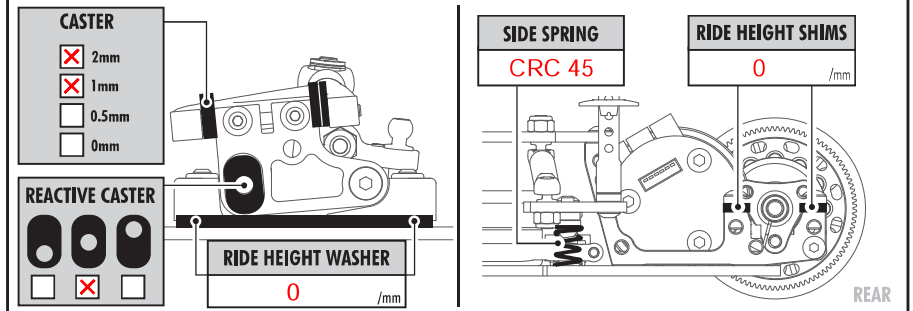
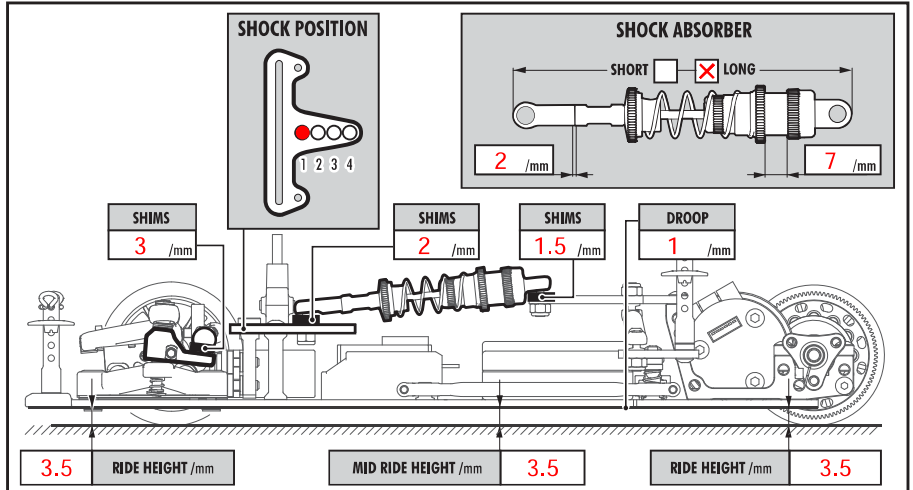

COMMENTS
 Car Pushed just a little but could keep pace with the leaders
 Battery Moved forward 15mm