

SET-UP SHEET

XRAY X12'16

RACE	US Indoor Champs 13.5
TRACK	Holiday Inn Ballroom - CRC Fast Track 2 C

NAME	Max Kuenning
CITY / COUNTRY	Albuquerque USA
CONTACT	maxkuenning@mac.com
DATE	02/12/2015

TEMPERATURE AIR	76	TEMPERATURE TRACK	
-----------------	----	-------------------	--

QUAL POSITION	5	FINAL POSITION	8.9	BEST LAP TIME	10 /sec	RACE LENGTH	9 /min
---------------	---	----------------	-----	---------------	---------	-------------	--------

TRACK	
TRACK SURFACE	<input checked="" type="checkbox"/> CARPET <input type="checkbox"/> ASPHALT
TRACK LAYOUT	<input type="checkbox"/> TECHNICAL <input checked="" type="checkbox"/> MIXED <input type="checkbox"/> FAST
TRACTION	<input type="checkbox"/> LOW <input type="checkbox"/> MEDIUM <input checked="" type="checkbox"/> HIGH

CENTER SHOCK ABSORBER					
SPRING	Black	OIL /cSt	500	REBOUND%	0
SIDE LINKAGES	<input checked="" type="checkbox"/>	OIL /cSt	40000		
SIDE SHOCK	<input type="checkbox"/>	OIL /cSt			

FRONT	TIRES	REAR
CRC Spec	TIRES TYPE	CRC Spec
40.0	DIAMETER /mm	40.5
SXT	ADDITIVE	SXT
5 Minutes	ADDITIVE TIMING	5 Minutes

FRONT LEFT	FRONT RIGHT	REAR LEFT	REAR RIGHT
ADDITIVE TREATED AREA			

TRANSMISSION		
DIFF SETTING		
<input type="checkbox"/> LOOSE	<input type="checkbox"/> MEDIUM	<input type="checkbox"/> TIGHT

GEARING	
PINION / T	SPUR GEAR/T
FINAL DRIVE RATIO	ROLLOUT NaN

ELECTRONICS	
MOTOR	Trinity Revtech 24K
SPEEDO	Tekin RS Spec
BATTERIES	Trinity White Carbon

BODY	
TYPE	PROTOform AMR PLW

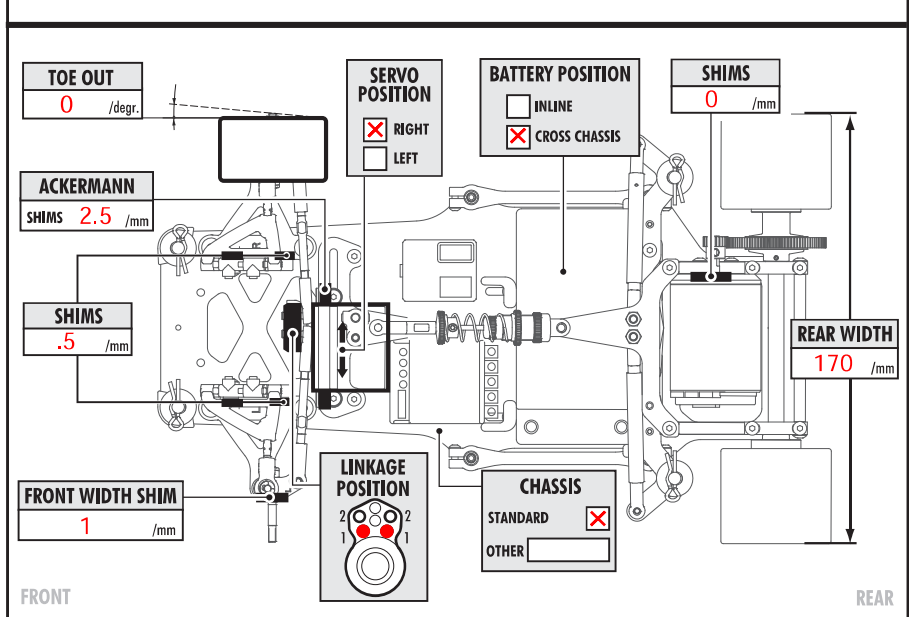
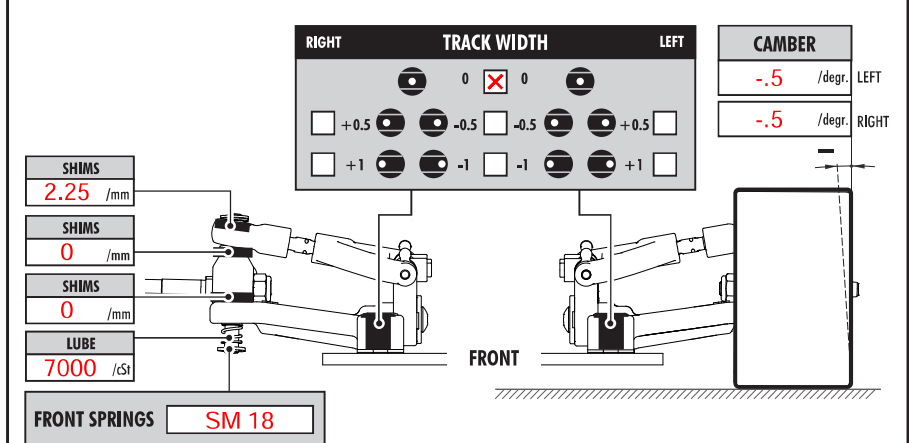
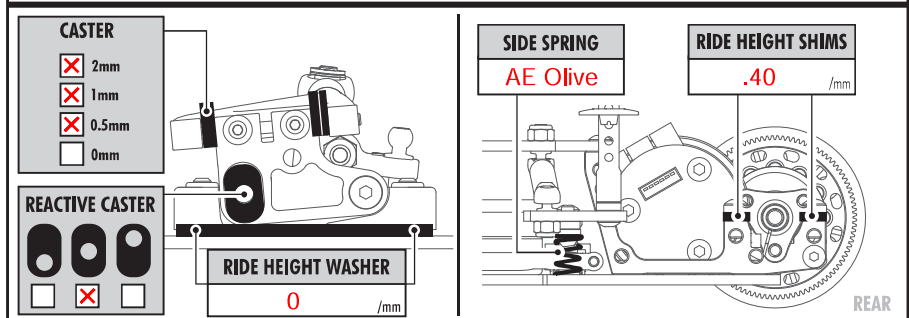
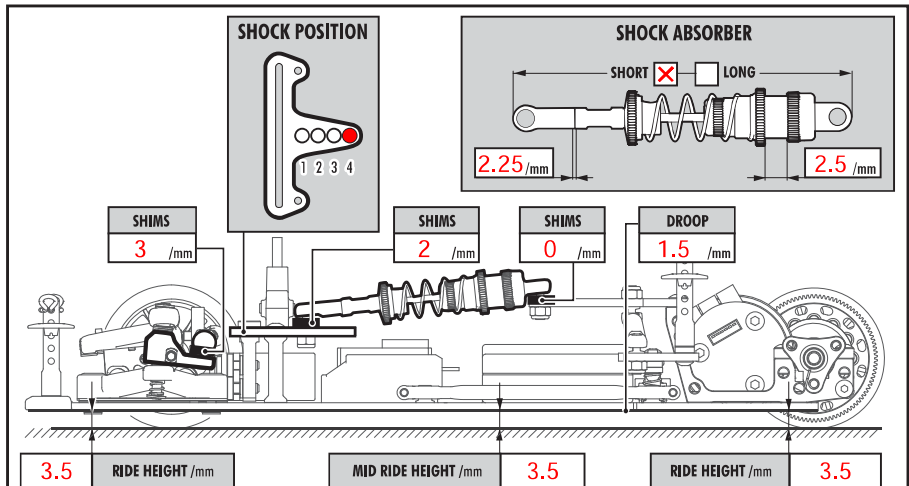

COMMENTS

Car was very fast and easy to drive. Could have finished better if it wouldn't have been for the 2nd lap incident.

Battery moved forward 15mm

Front brace in-between caster blocks