

# SET-UP SHEET

# XRAY X12'15

<b>RACE</b>	Club Race Mod	
<b>TRACK</b>	5280 Raceway	

<b>NAME</b>	Max Kuenning	
<b>CITY / COUNTRY</b>	Denver, CO	USA
<b>CONTACT</b>	max.fx77@gmail.com	

<b>DATE</b>	28/09/2015	
<b>TEMPERATURE</b> / <small>F or °C</small>	AIR 80	TRACK

<b>QUALIFYING POSITION</b>	<b>BEST LAPTIME</b> / sec	<b>FINAL POSITION</b>	<b>RACE LENGTH</b> / minutes
	8.3		

<b>TRACK CONDITION</b>	<input checked="" type="checkbox"/> CARPET	<input type="checkbox"/> ASPHALT
	<input checked="" type="checkbox"/> TECHNICAL	<input type="checkbox"/> MIXED
<b>TRACTION</b>	<input type="checkbox"/> LOW	<input checked="" type="checkbox"/> MEDIUM
		<input type="checkbox"/> HIGH

CENTER SHOCK ABSORBER			
<b>SPRING</b>	YOK Silver	<b>OIL / cSt</b>	700
		<b>REBOUND%</b>	

<b>SIDE LINKAGES</b>	<input checked="" type="checkbox"/>	<b>OIL / cSt</b>	10000
<b>SIDE SHOCK</b>	<input type="checkbox"/>	<b>OIL / cSt</b>	

FRONT		TIRES	REAR	
XM			XM	
40		DIAMETER/mm	41	
SXT		ADDITIVE	SXT	
5min		ADDITIVE timing	15min	



TRANSMISSION			
DIFF SETTING			
<input type="checkbox"/> LOOSE	<input type="checkbox"/>	<input type="checkbox"/> MEDIUM	<input checked="" type="checkbox"/> TIGHT

<b>PINION / T</b>	25	<b>SPUR GEAR/T</b>	94
<b>FINAL DRIVE RATIO</b>	3.76	<b>ROLLOUT</b>	34.239

ELECTRONICS	
<b>MOTOR</b>	Trinity D4 3.5
<b>SPEEDO</b>	Tekin RSX
<b>BATTERIES</b>	Trinity White Carbon HC

<b>BODY</b>	PROTOform AMR12 ULW
-------------	---------------------

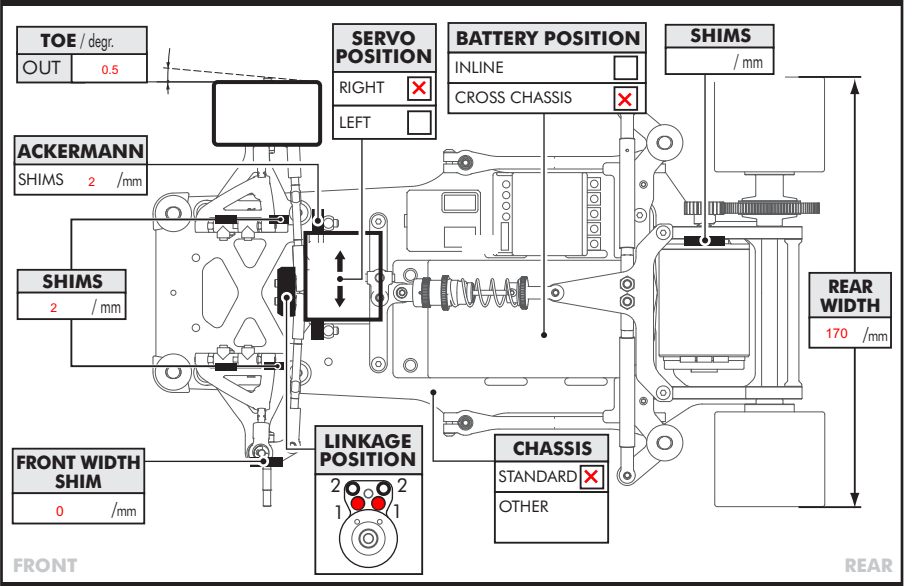
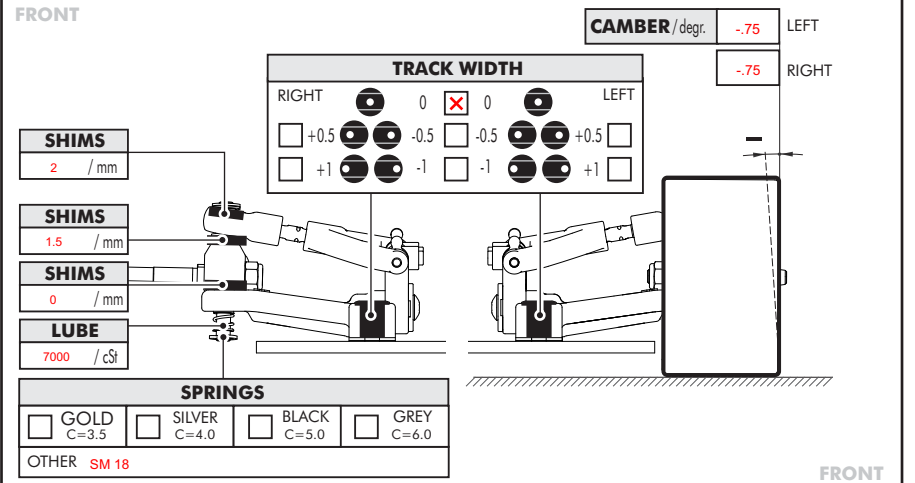
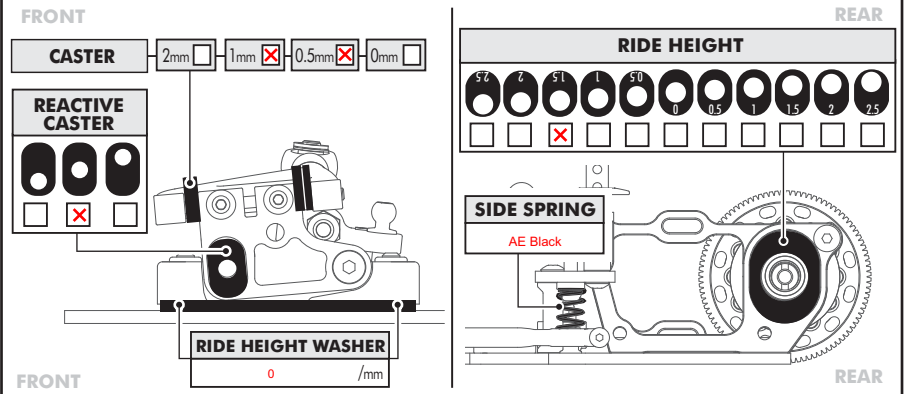
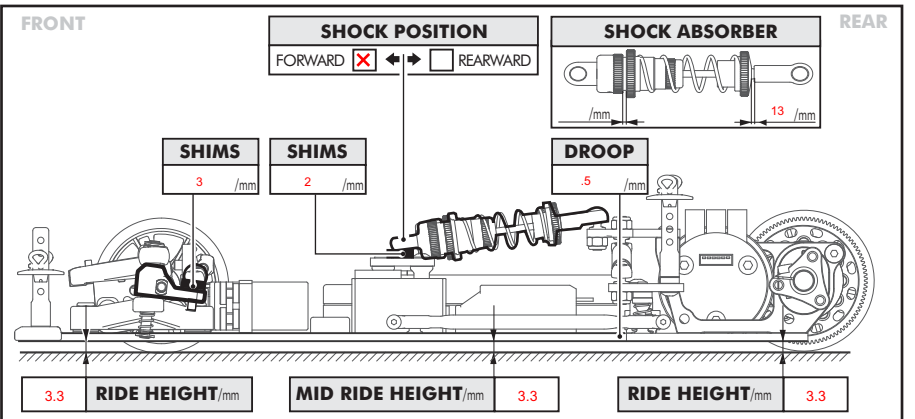

COMMENTS **Battery forward**  
**Side Springs half turn off rear lower pod plate**