

SET-UP SHEET

XRAY X12'15

RACE	IIC Las Vegas - winning set-up	
TRACK	Riviera ballroom	

NAME	Alexander Hagberg	
CITY / COUNTRY	Las Vegas	USA
CONTACT	alexander.hagberg@gmail.com	

DATE	21/10/2014	
TEMPERATURE / <small>F or °C</small>	AIR	TRACK

QUALIFYING POSITION	BEST LAP TIME / sec	FINAL POSITION	RACE LENGTH / minutes
1		1	8

TRACK CONDITION	<input checked="" type="checkbox"/> CARPET	<input type="checkbox"/> ASPHALT
	<input type="checkbox"/> TECHNICAL	<input checked="" type="checkbox"/> MIXED
		<input type="checkbox"/> FAST

TRACTION		
<input type="checkbox"/> LOW	<input type="checkbox"/> MEDIUM	<input checked="" type="checkbox"/> HIGH

CENTER SHOCK ABSORBER			
SPRING	Gold	OIL / cSt	500
		REBOUND %	25

SIDE LINKAGES	<input checked="" type="checkbox"/>	OIL / cSt	10.000
SIDE SHOCK	<input type="checkbox"/>	OIL / cSt	

FRONT		TIRES	REAR	
Hot Race 32			Hot Race 30	
40.4		DIAMETER/mm	41.8	
SXT 3.0		ADDITIVE	SXT 3.0	
5		ADDITIVE timing	10	

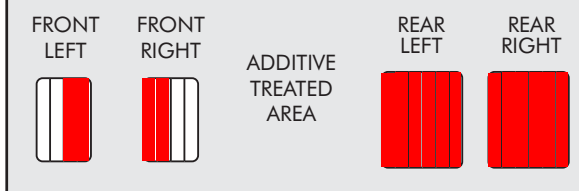

TRANSMISSION			
DIFF SETTING			
<input type="checkbox"/> LOOSE	<input type="checkbox"/>	<input type="checkbox"/> MEDIUM	<input checked="" type="checkbox"/> TIGHT

PINION / T	27	SPUR GEAR / T	96
FINAL DRIVE RATIO	3.5556	ROLLOUT	36.914

ELECTRONICS	
MOTOR	ORCA TX 4.0T
SPEEDO	ORCA VX3 1S
BATTERIES	ORCA INFINITE 6800 80C

BODY	PF AMR-12
-------------	-----------

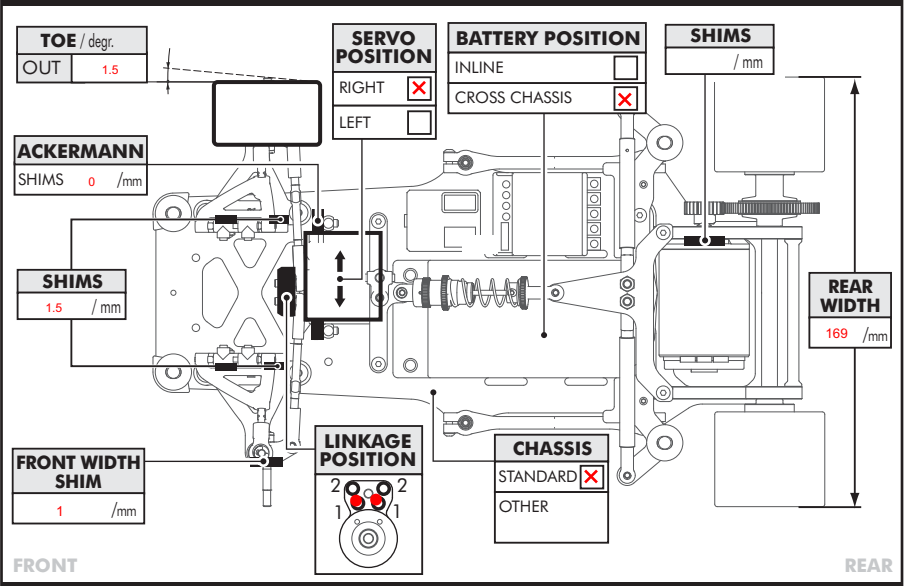
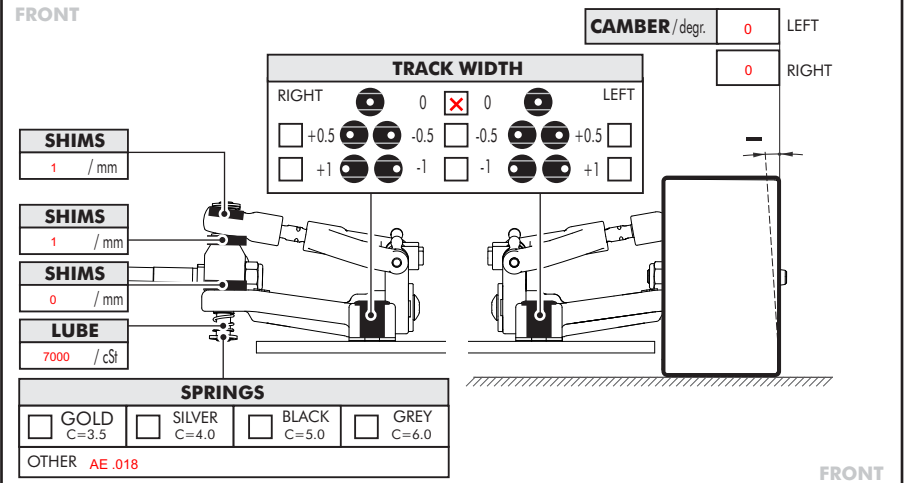
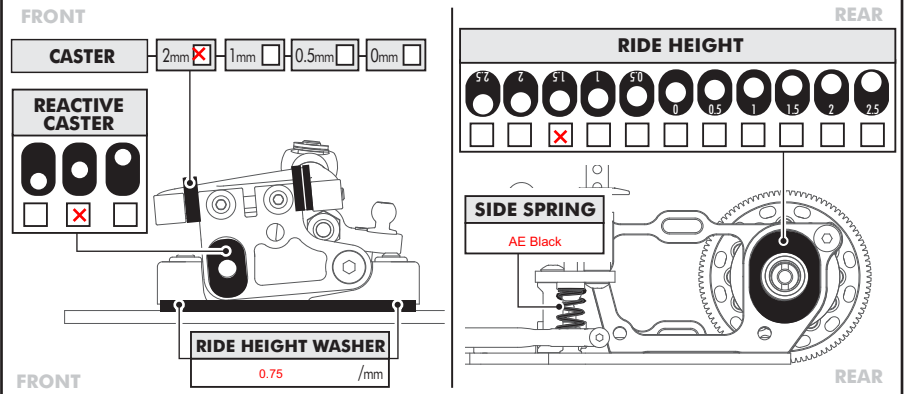
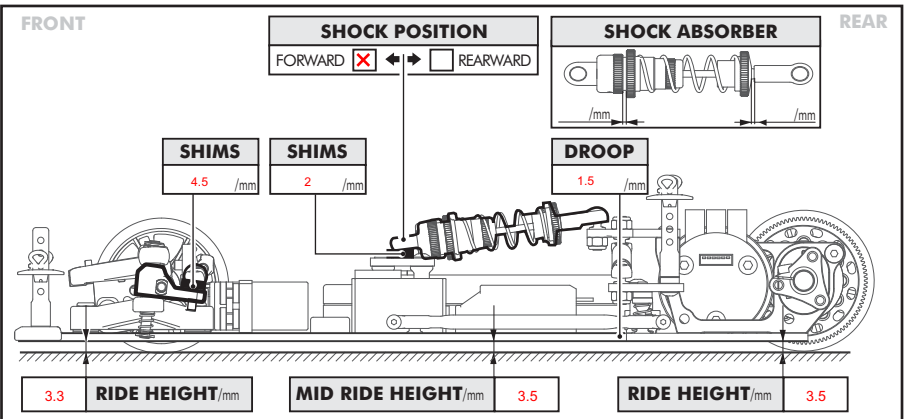

COMMENTS 0.5mm of droop in front suspension