

SET-UP SHEET

RACE	2013 IIC CHAMPS	
TRACK	LAS VEGAS	

NAME	Eric Anderson	
CITY / COUNTRY	LAS VEGAS	USA
CONTACT	TEAMEAM@ME.COM	

DATE	30/10/2013	
TEMPERATURE/°F or °C	AIR	TRACK

QUALIFYING POSITION	BEST LAP TIME / sec	FINAL POSITION	RACE LENGTH / minutes
2	9.0	2	8

TRACK CONDITION	<input checked="" type="checkbox"/> CARPET	<input type="checkbox"/> ASPHALT
	<input type="checkbox"/> TECHNICAL	<input checked="" type="checkbox"/> MIXED
	<input type="checkbox"/> FAST	
TRACTION		
	<input type="checkbox"/> LOW	<input type="checkbox"/> MEDIUM
	<input checked="" type="checkbox"/> HIGH	

CENTER SHOCK ABSORBER			
SPRING	STOCK	OIL / cSt	700
		REBOUND%	0

SIDE LINKAGES	
OIL / cSt	15K

FRONT		TIRES	REAR	
BSR TEAM PURPLE			BSR BLUE	
40		DIAMETER/mm	41	
JACK		ADDITIVE	JACK	
10 MIN		ADDITIVE timing	10 MIN	
FRONT LEFT	FRONT RIGHT	ADDITIVE TREATED AREA	REAR LEFT	REAR RIGHT

TRANSMISSION	
DIFF SETTING	
<input type="checkbox"/> LOOSE	<input checked="" type="checkbox"/> MEDIUM
<input type="checkbox"/>	<input type="checkbox"/> TIGHT

PINION / T	48	SPUR GEAR/T	76
FINAL DRIVE RATIO	1.58333333333333	ROLLOUT	81.309473684211

MOTOR	
BRAND	TEAM EAM/ORCA 13.5
TURN	13.5
ROTOR	STOCK
TIMING	50 DEGREES

ESC	ORCA VX-1		
ESC SETTING	PROGRAM	BLINKY	PUNCH
	INITIAL BRAKE	0	AUTO BRAKE
BATTERIES	TEAM EAM 7000 80C		
BODY	PROTOFORM AMR-12		

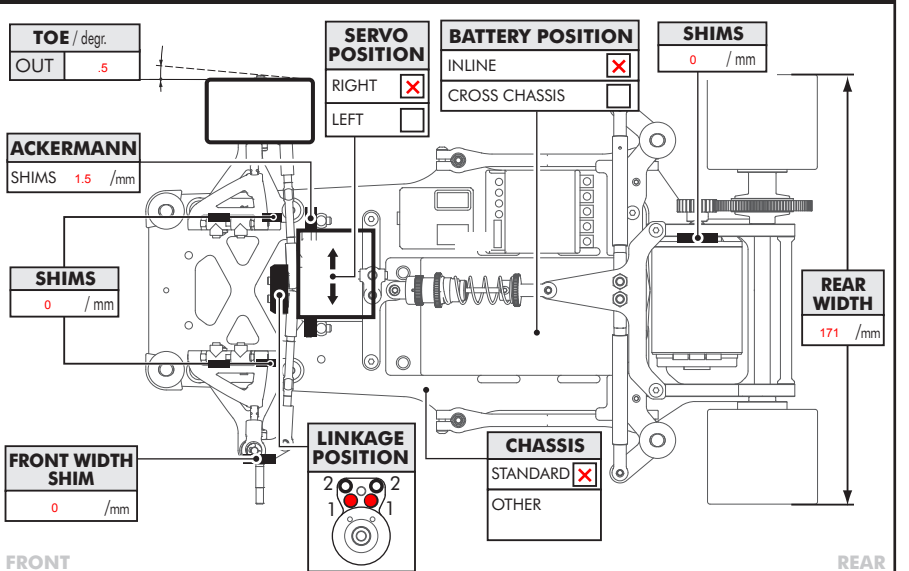
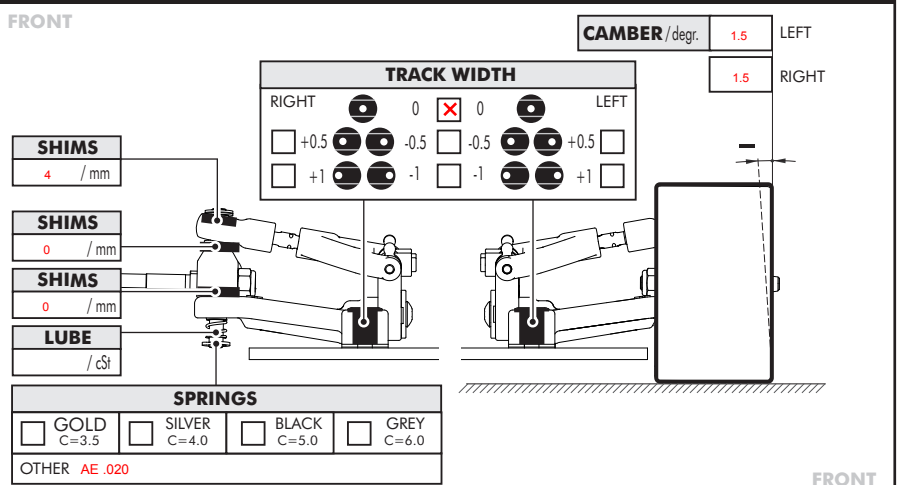
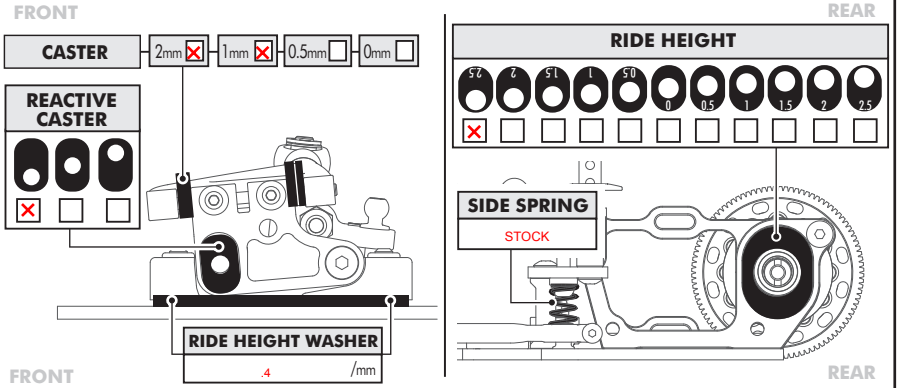
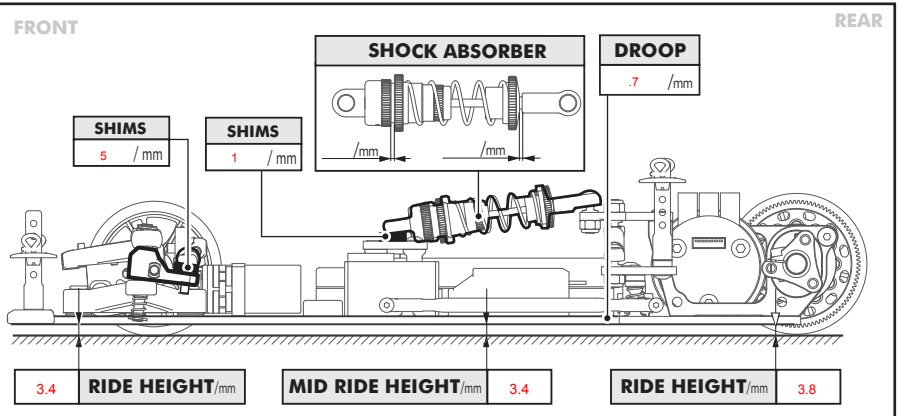

COMMENTS

The car was super easy to drive and fast. It needed a touch more steering and Magenta fronts would have done the trick as I ran them at the Halloween Classic and it was much better. cant wait to do more testing!