

SET-UP SHEET

RACE	2013 Halloween Classic	
TRACK	The Gate	

NAME	Eric Anderson	
CITY / COUNTRY	Cleveland	USA
CONTACT	TEAMEAM@ME.COM	

DATE	30/10/2013	
TEMPERATURE / °F or °C	AIR	TRACK

QUALIFYING POSITION	BEST LAP TIME / sec	FINAL POSITION	RACE LENGTH / minutes
1	8.4	1	8

TRACK CONDITION	<input checked="" type="checkbox"/> CARPET	<input type="checkbox"/> ASPHALT
	<input checked="" type="checkbox"/> TECHNICAL	<input type="checkbox"/> MIXED
	<input type="checkbox"/> FAST	
TRACTION	<input type="checkbox"/> LOW	<input type="checkbox"/> MEDIUM
	<input checked="" type="checkbox"/> HIGH	

CENTER SHOCK ABSORBER			
SPRING	Asc blue	OIL / cSt	40wt
		REBOUND %	0

SIDE LINKAGES	
OIL / cSt	15K

FRONT		TIRES	REAR	
BSR MAGENTA			BSR BLUE	
40		DIAMETER/mm	41	
SXT		ADDITIVE	SXT	
8		ADDITIVE timing	20	

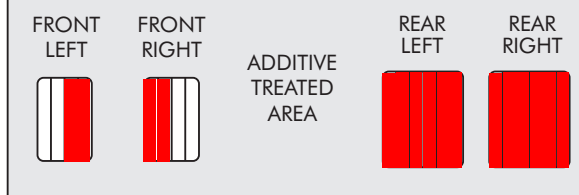

TRANSMISSION	
DIFF SETTING	
<input type="checkbox"/> LOOSE	<input checked="" type="checkbox"/> MEDIUM
<input type="checkbox"/> TIGHT	

PINION / T	48	SPUR GEAR/T	76
FINAL DRIVE RATIO	1.58333333333333	ROLLOUT	81.309473684211

MOTOR	
BRAND	TEAM EAM D3.5
TURN	13.5
ROTOR	12.5 HT
TIMING	22 DEGREES

ESC	ORCA VX-1		
ESC SETTING	PROGRAM	BLINKY	PUNCH
	INITIAL BRAKE	0	AUTO BRAKE
BATTERIES	TEAM EAM 7000 80C		
BODY	PROTOFORM AMR-12		

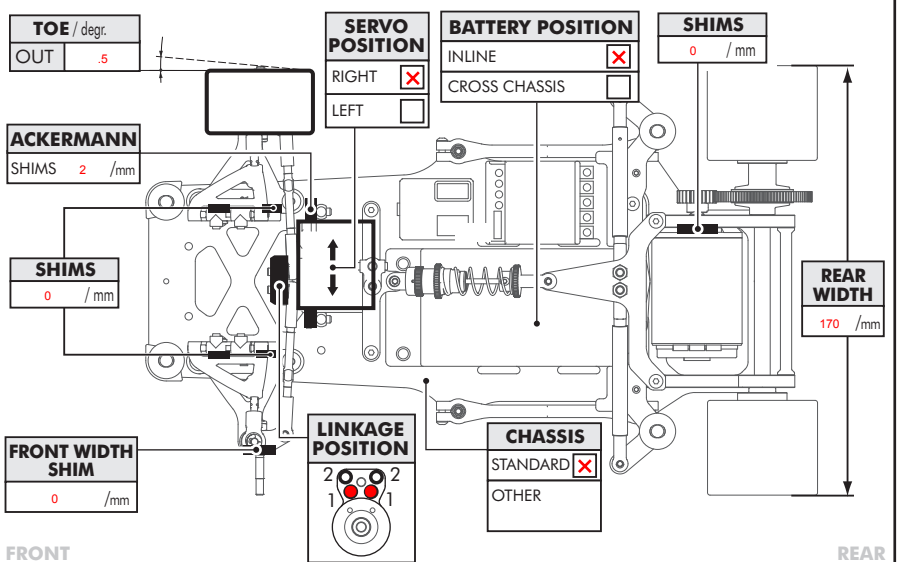
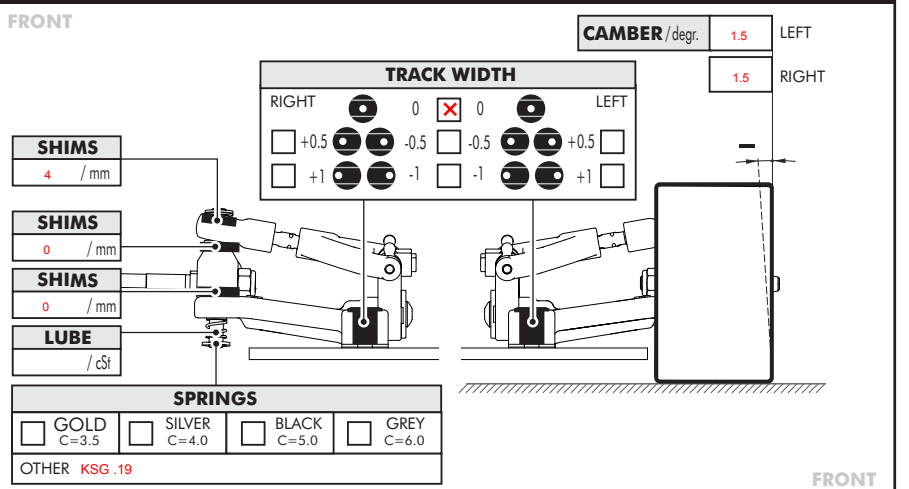
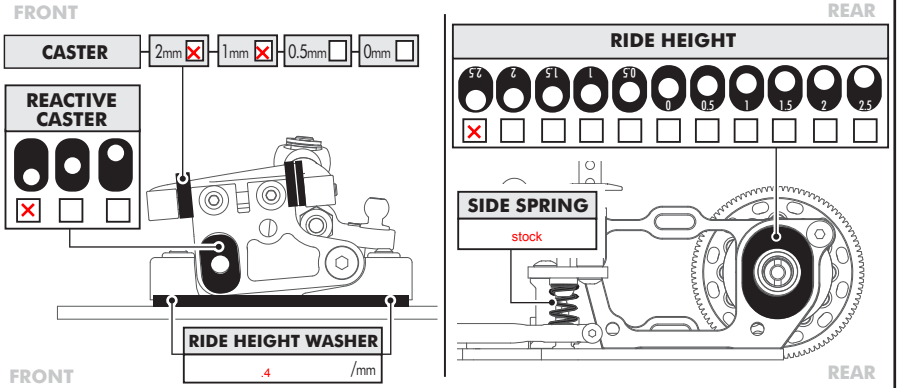
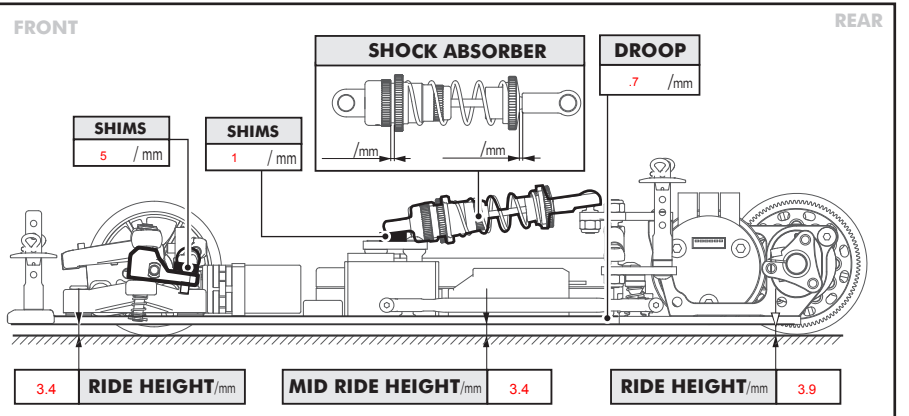

COMMENTS
 The car was super easy to drive. lap times did not fall off. Had the fastest laps of the week by .2 a lap.

Note: I used a Hotbodies center shock to get the feel I was looking for on the tighter track due to spring rates.