

SET-UP SHEET

XRAY T4'14

RACE	Mibosport Cup		
TRACK	Hrotovice		
NAME	Anonymous		
CITY / COUNTRY	Kroměříž	Czech Republic	
CONTACT	Marekcerny2@centrum.cz		

DATE	17/02/2014	TEMPERATURE / °F or °C	AIR	20	TRACK	20
------	------------	------------------------	-----	----	-------	----

QUALIFYING POSITION	BEST LAPTIME /sec	FINAL POSITION	RACE LENGTH /minutes
1	11,8	1	5

TRACK CONDITION	<input checked="" type="checkbox"/> CARPET	<input type="checkbox"/> ASPHALT	
	<input type="checkbox"/> TECHNICAL	<input checked="" type="checkbox"/> FAST	
TRACTION	<input type="checkbox"/> LOW	<input checked="" type="checkbox"/> MEDIUM	<input type="checkbox"/> HIGH

FRONT	REAR
TRANSMISSION	

SOLID AXLE	<input checked="" type="checkbox"/> YES	BALL DIFFERENTIAL	<input type="checkbox"/> YES
SOLID ONE WAY DIFF.	<input type="checkbox"/> YES		
ONE WAY DIFFERENTIAL	<input type="checkbox"/> YES		

GEAR DIFFERENTIAL	<input type="checkbox"/> YES	GEAR DIFFERENTIAL	<input checked="" type="checkbox"/> YES
OIL		OIL	4000 /Cst

PINION / T	23	SPUR GEAR / T	100
FINAL DRIVE RATIO	4.3478260869565	ROLLOUT	NaN

FRONT	REAR
-------	------

2,5-2,8	XRAY SPRINGS	2,6
350	OIL / CST	400
st	LENGTH /mm	st
	PRELOAD /mm	
0	REBOUND %	0

<input type="checkbox"/> YES <input checked="" type="checkbox"/> NO	FOAM INSERTS	<input type="checkbox"/> YES <input checked="" type="checkbox"/> NO
<input type="checkbox"/> YES <input checked="" type="checkbox"/> NO	O-RING ON SHAFT	<input type="checkbox"/> YES <input checked="" type="checkbox"/> NO

<input checked="" type="checkbox"/> 3 HOLES	PISTONS	<input type="checkbox"/> 3 HOLES
<input type="checkbox"/> 4 HOLES	1.0mm	<input checked="" type="checkbox"/> 4 HOLES
	1.1mm	<input type="checkbox"/> 4 HOLES
	1.2mm	<input checked="" type="checkbox"/> 4 HOLES
	OTHERS	

1,4	THICKNESS/mm	ANTI-ROLL BAR	THICKNESS/mm	1,3
-----	--------------	---------------	--------------	-----

RIDE	TIRES	RIDE
	INSERTS	
HUDY	ADDITIVE	HUDY
5	ADDITIVE TIMING	10

FRONT LEFT	FRONT RIGHT	REAR LEFT	REAR RIGHT
TREATED AREA			

WHEELS	
S <input type="checkbox"/> M <input type="checkbox"/> H <input type="checkbox"/>	HARDNESS

MOTOR	LRP X20 4,5t	TIMING	-10
ROTOR	st	ARMATURE	

ESC	LRP Flow	BATTERIES	LRP 5700mAh
-----	----------	-----------	-------------

BODY	Mazda 6SP LW	WING	MR33
------	--------------	------	------

● - APPLIED S - SOFT M - MEDIUM H - HARD

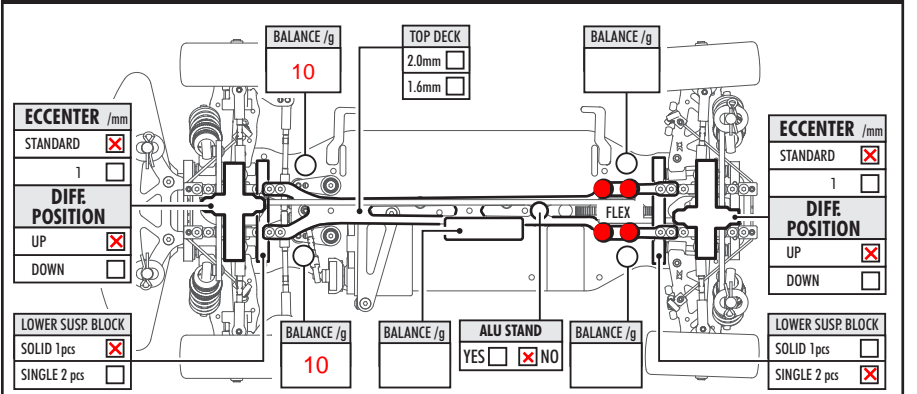
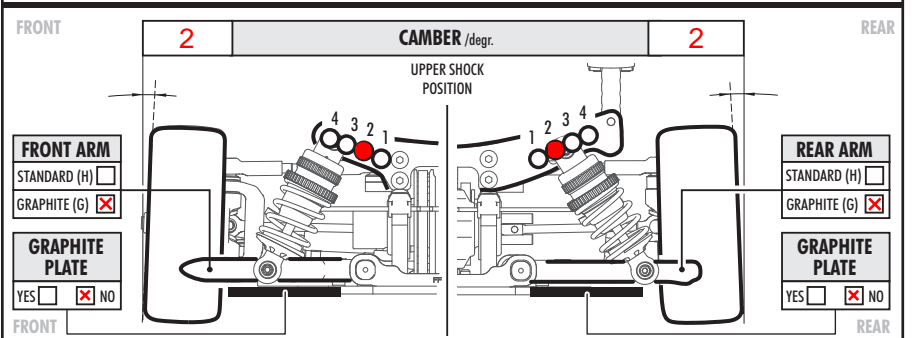
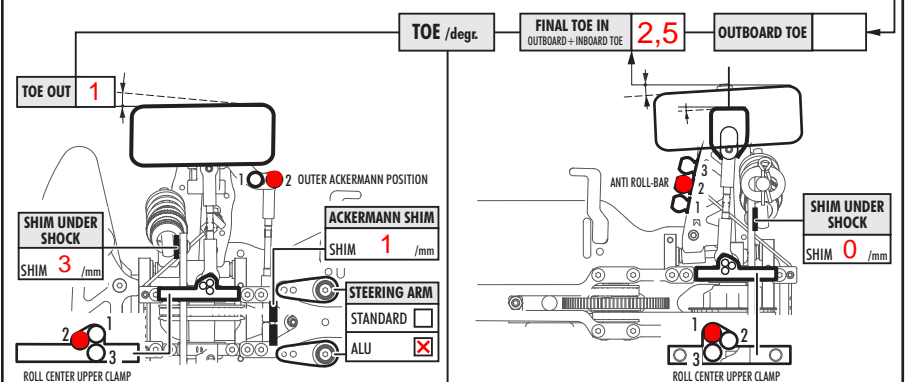
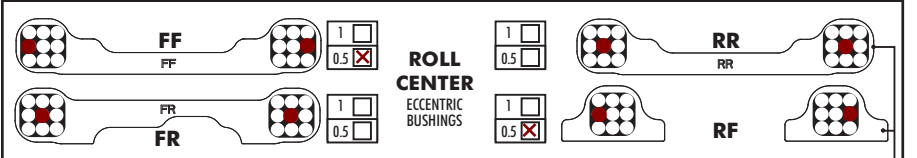
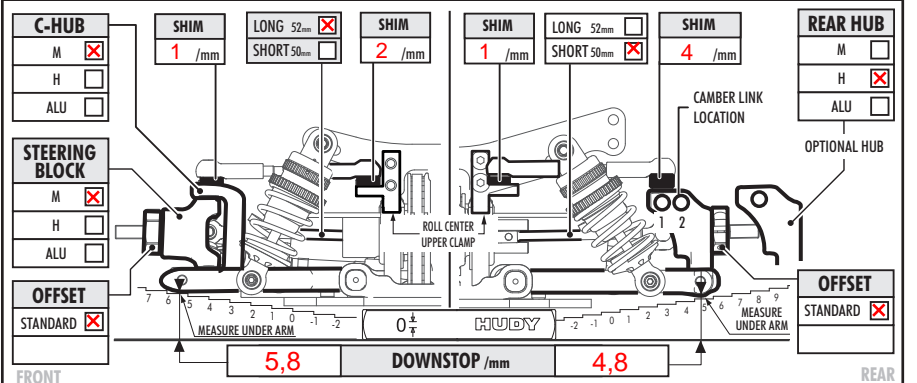
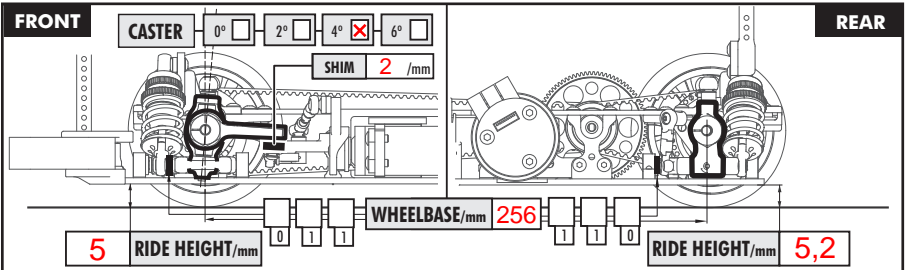

COMMENTS
ECS font