

SET-UP SHEET

RACE	2009 EP Australian Titles	
TRACK	Whalan	

NAME	Timothy Lee	
CITY / COUNTRY	Sydney	Australia
CONTACT		

DATE	27/11/2009		
TEMPERATURE / For °C	AIR 40°C	TRACK 68°C	

QUALIFYING POSITION	BEST LAPTIME / sec	FINAL POSITION	RACE LENGTH / minutes
4	17.5	3	8

TRACK CONDITION	<input type="checkbox"/> CARPET	<input checked="" type="checkbox"/> ASPHALT
	<input type="checkbox"/> TECHNICAL	<input type="checkbox"/> MIXED
TRACTION	<input type="checkbox"/> LOW	<input checked="" type="checkbox"/> MEDIUM
		<input type="checkbox"/> HIGH

SHOCK ABSORBER	
SPRING	std
OIL / cSt	300
REBOUND %	50

FRONT	TIRES	REAR
Jaco Purple		JACO Pink
43.5	DIAMETER/mm	48
Ground Effects	ADDITIVE	Ground Effects
30min	ADDITIVE timing	60min
FRONT LEFT	FRONT RIGHT	REAR LEFT
	ADDITIVE TREATED AREA	

TRANSMISSION	
DIFF SETTING	
<input type="checkbox"/> LOOSE	<input checked="" type="checkbox"/> MEDIUM
	<input type="checkbox"/> TIGHT
PINION / T	SPUR GEAR/T
FINAL DRIVE RATIO	ROLLOUT
	0

BRUSHED MOTOR	
BRAND	
ARMATURE	
	<input checked="" type="checkbox"/> SPRING
	<input checked="" type="checkbox"/> BRUSH COMP.

BRUSHLESS MOTOR	
BRAND	LRP
TURN	4.5
ROTOR	12.5
TIMING	2

ESC	LRP Sphere Comp 2007	
ESC SETTING	PROGRAM 2	PUNCH 2
	INITIAL BRAKE 1	AUTO BRAKE 0
BATTERIES	IB 5000	
BODY	BlackArt Audi R8C	

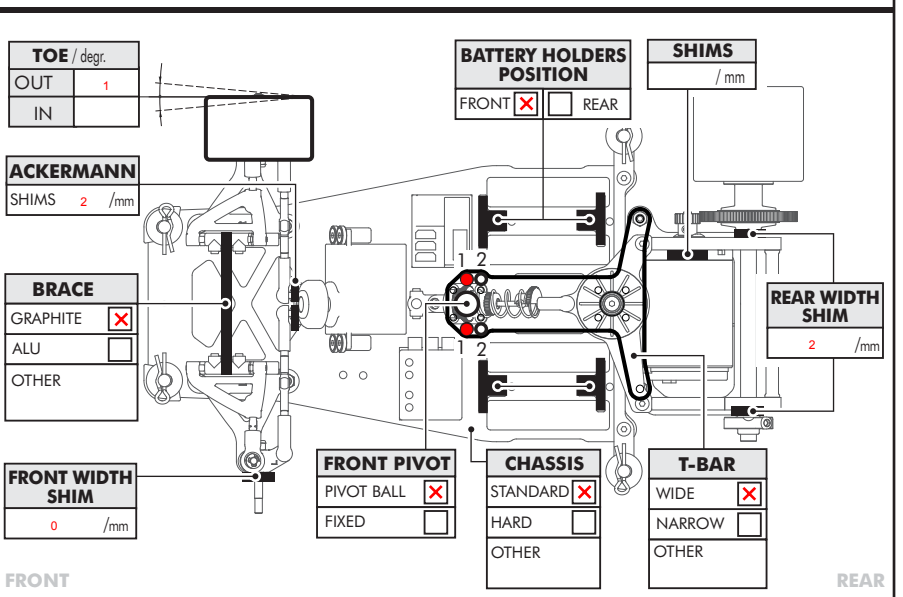
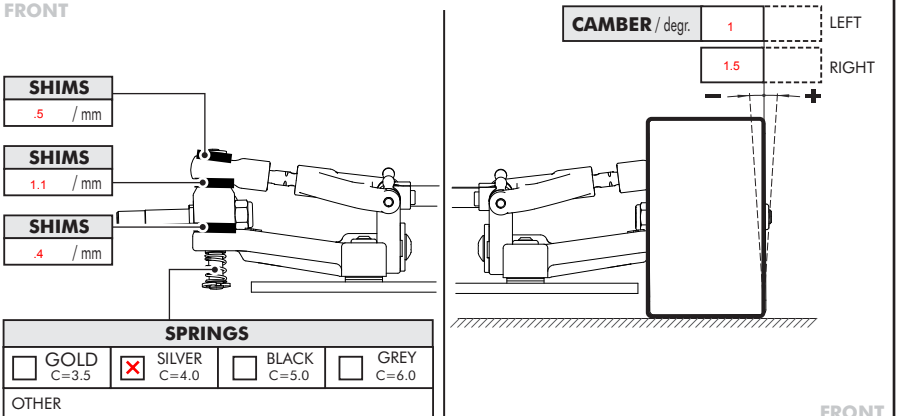
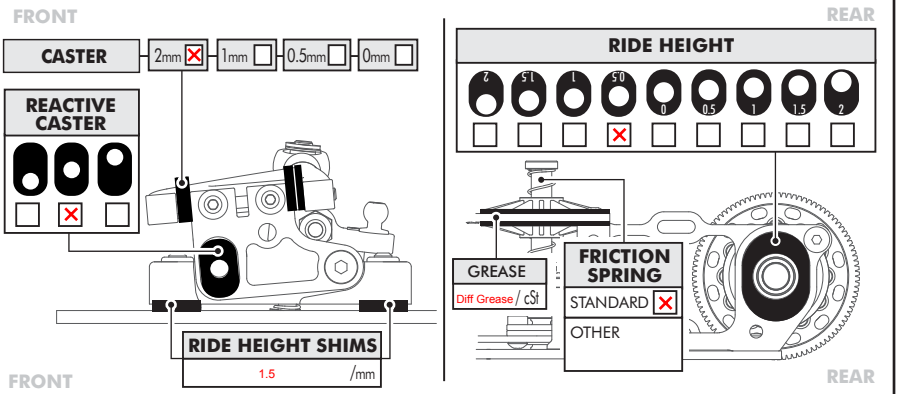
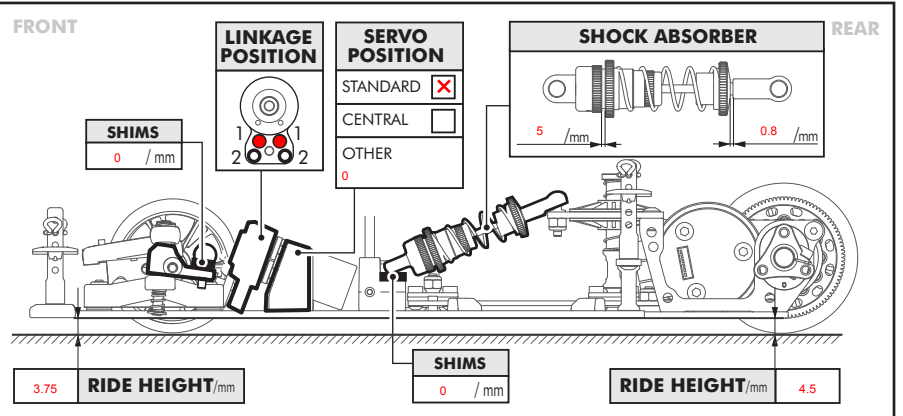

COMMENTS