

SET-UP SHEET

XRAY XII

RACE	CS-Cup 4	
TRACK	Indoor Braunschweig	

NAME	Christian Schamp	
CITY / COUNTRY	Braunschweig	Germany
CONTACT	c.schamp@t-online.de	

DATE	15/02/2009	
-------------	------------	--

TEMPERATURE / °F or °C	AIR	TRACK
-------------------------------	-----	-------

QUALIFYING POSITION	BEST LAPTIME / sec	FINAL POSITION	RACE LENGTH / minutes
1	10.5	1	8

TRACK CONDITION	<input type="checkbox"/> CARPET	<input type="checkbox"/> ASPHALT
	<input type="checkbox"/> TECHNICAL	<input type="checkbox"/> MIXED <input checked="" type="checkbox"/> FAST

TRACTION	<input type="checkbox"/> LOW	<input type="checkbox"/> MEDIUM	<input checked="" type="checkbox"/> HIGH
-----------------	------------------------------	---------------------------------	------------------------------------------

SHOCK ABSORBER	
SPRING	Kit
OIL / cSt	250
REBOUND %	50

FRONT		TIRES	REAR	
Jaco Purple			Jaco Pink	
44		DIAMETER/mm	46	
CS High		ADDITIVE	CS High	
10		ADDITIVE timing	40	
FRONT LEFT	FRONT RIGHT	ADDITIVE TREATED AREA	REAR LEFT	REAR RIGHT

TRANSMISSION	
DIFF SETTING	
<input type="checkbox"/> LOOSE	<input type="checkbox"/> MEDIUM <input checked="" type="checkbox"/> TIGHT

PINION / T	34	SPUR GEAR /T	96
FINAL DRIVE RATIO	4.8	ROLLOUT	28.783

BRUSHED MOTOR	
BRAND	
ARMATURE	
	<input checked="" type="checkbox"/> SPRING <input type="checkbox"/>
	<input checked="" type="checkbox"/> BRUSH COMP. <input type="checkbox"/>

BRUSHLESS MOTOR	
BRAND	CS
TURN	9.5T
ROTOR	12.5 with Fan
TIMING	

ESC	LRP SPX			
ESC SETTING	PROGRAM	2	PUNCH	8
	INITIAL BRAKE	0	AUTO BRAKE	0

BATTERIES	CS 4600 MCS	
BODY	PF Speed 12	

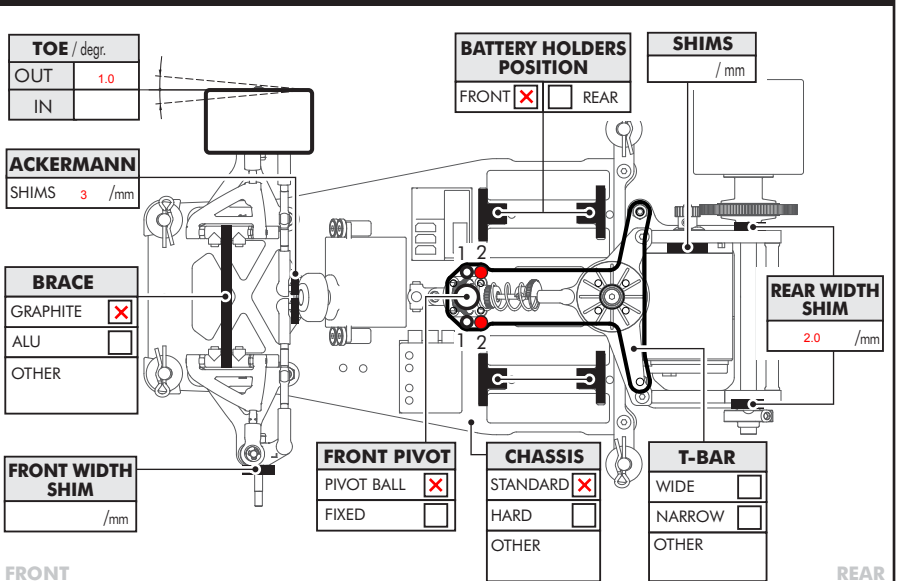
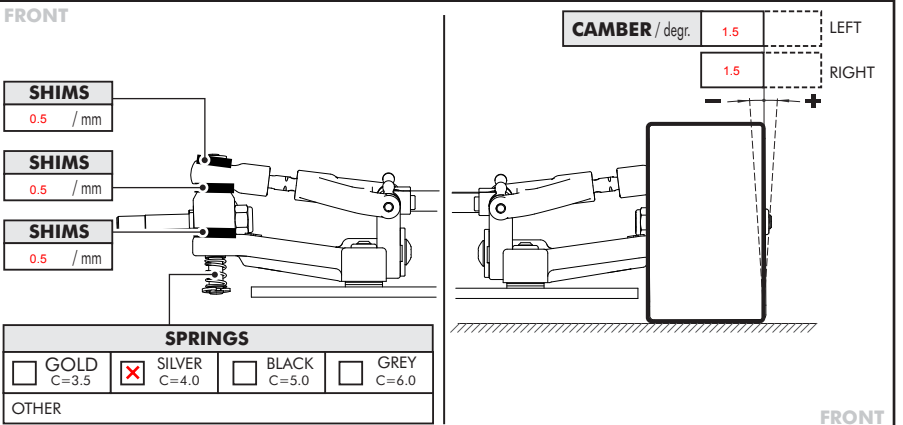
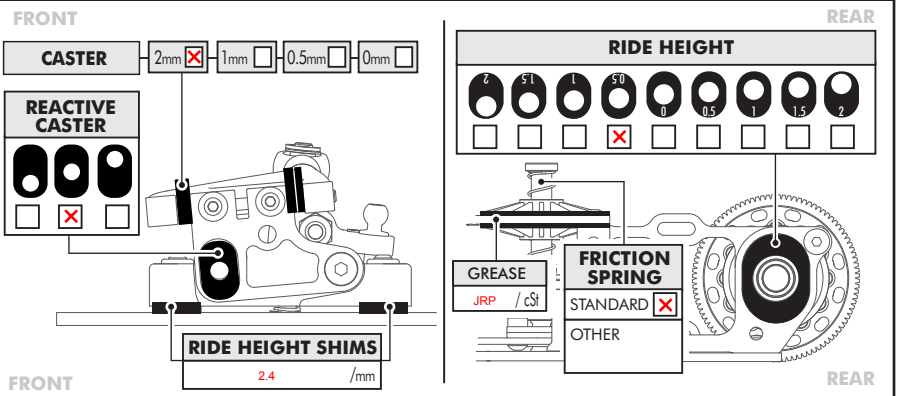
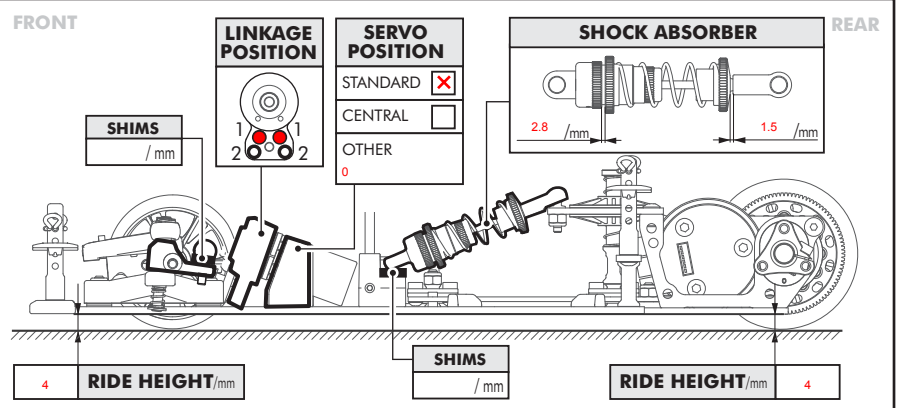

COMMENTS