

SET-UP SHEET

XRAY T2 '007

RACE	Schumacher BTCC		
TRACK	Cotswolds		
NAME	Ali Graham		
CITY / COUNTRY	Manchester	UK	
CONTACT	ali303@hotmail.co.uk		

DATE	22/07/2007	TEMPERATURE / °F or °C	AIR	22	TRACK
------	------------	------------------------	-----	----	-------

QUALIFYING POSITION	BEST LAP TIME / sec	FINAL POSITION	RACE LENGTH / minutes
11	17.8	11	5

TRACK CONDITION	<input type="checkbox"/> TECHNICAL	<input type="checkbox"/> CARPET	<input checked="" type="checkbox"/> ASPHALT
	<input type="checkbox"/> MIXED	<input type="checkbox"/> FAST	
TRACTION	<input type="checkbox"/> LOW	<input checked="" type="checkbox"/> MEDIUM	<input type="checkbox"/> HIGH

FRONT	REAR
TRANSMISSION	
DIFFERENTIAL	

LOOSE	MEDIUM	TIGHT	LOOSE	MEDIUM	TIGHT
<input type="checkbox"/>	<input type="checkbox"/>	<input type="checkbox"/>	<input type="checkbox"/>	<input type="checkbox"/>	<input checked="" type="checkbox"/>

ONE WAY DIFFERENTIAL	<input type="checkbox"/> YES	MIDDLE ONE WAY PULLEY	
SOLID ONE WAY DIFF.	<input type="checkbox"/> YES	FIXED	<input checked="" type="checkbox"/>
SOLID AXLE	<input checked="" type="checkbox"/> YES	ONE-WAY	<input type="checkbox"/>

PINION / T	26	SPUR GEAR / T	116
FINAL DRIVE RATIO	7.585	ROLLOUT	0

FRONT	REAR
<input type="checkbox"/> ALU	<input type="checkbox"/> PLASTIC
<input type="checkbox"/> ALU	<input type="checkbox"/> PLASTIC

XRAY SPRINGS					
#308393	Super Soft	<input type="checkbox"/> YELLOW	<input type="checkbox"/>	(D=1.4)	14 lb
#308384		<input type="checkbox"/> BLUE-GREEN	<input type="checkbox"/>	(D=1.5)	15 lb
#308394	Soft	<input type="checkbox"/> WHITE	<input type="checkbox"/>	(D=1.5)	17.5 lb
#308385		<input type="checkbox"/> LIGHT-BLUE	<input type="checkbox"/>	(D=1.6)	20 lb
#308395	Soft Medium	<input type="checkbox"/> BLUE	<input type="checkbox"/>	(D=1.6)	22.5 lb
#308386		<input type="checkbox"/> DARK-BLUE	<input type="checkbox"/>	(D=1.7)	25 lb
#308396	Medium	<input type="checkbox"/> VIOLET	<input type="checkbox"/>	(D=1.7)	28 lb
#308387		<input type="checkbox"/> LIGHT-PURPLE	<input type="checkbox"/>	(D=1.8)	30 lb
#308397	Medium Hard	<input type="checkbox"/> PURPLE	<input type="checkbox"/>	(D=1.8)	33 lb
#308388		<input type="checkbox"/> LIGHT-RED	<input type="checkbox"/>	(D=1.9)	35 lb
#308398	Hard	<input type="checkbox"/> RED	<input type="checkbox"/>	(D=1.9)	38 lb

HPI Pink	OTHER SPRING	HPI Silver
Xray 400	OIL / W	Xray 400
66	LENGTH / mm	66
	PRELOAD / mm	
75%	REBOUND %	75%
<input checked="" type="checkbox"/> YES	<input type="checkbox"/> NO	<input checked="" type="checkbox"/> YES
<input type="checkbox"/> YES	<input checked="" type="checkbox"/> NO	<input type="checkbox"/> YES
	FOAM INSERTS	<input type="checkbox"/> YES
	O-RING ON SHAFT	<input checked="" type="checkbox"/> NO

<input type="checkbox"/> OPENED	<input checked="" type="checkbox"/> CLOSED	HOLES IN PISTON
---------------------------------	--	-----------------

1.4	THICKNESS / mm	ANTI-ROLL BAR	THICKNESS / mm	1.2
-----	----------------	---------------	----------------	-----

Sorex 32	TIRES	Sorex 32
	DIAMETER / mm	
	INSERTS	

Tweak	ADDITIVE	Tweak		
FRONT LEFT	FRONT RIGHT	TREATED AREA	REAR LEFT	REAR RIGHT

WHEELS			
S	M	<input checked="" type="checkbox"/> H	
		HARDNESS	S M <input checked="" type="checkbox"/> H

MOTOR	Nosram	ARMATURE	3.5T	TIMING	2
		+ SPRING	-		
		+ BRUSH FACE	-		
		+ BRUSH COMP.	-		

ESC	Nosram ISTC	BATTERIES	Nosram 4200 BIG MAMA SV2
BODY	Protoform Mazda	WING	Std

COMMENTS
1.2mm piston
Bad luck in qualifying, car right on pace. Super stable at high speed.

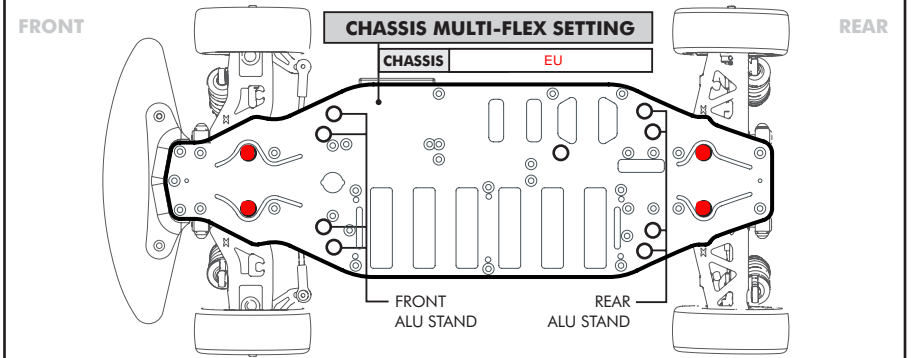
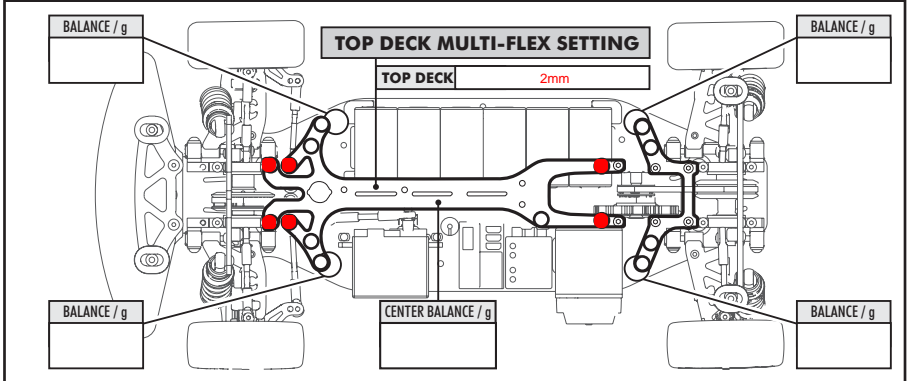
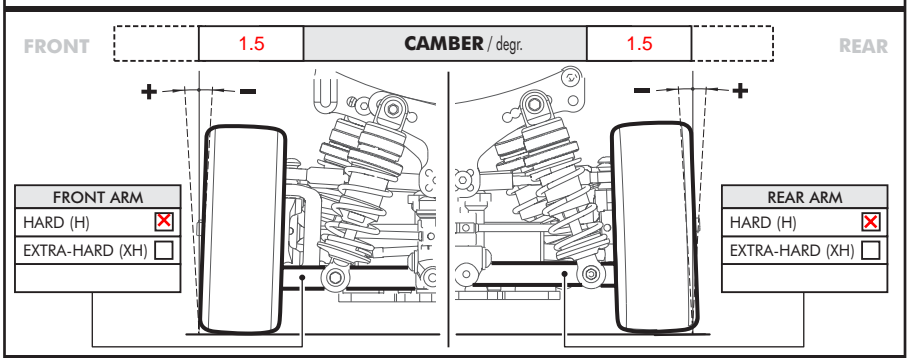
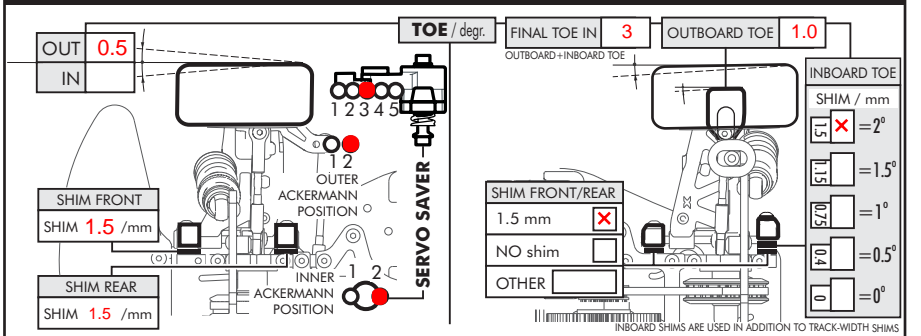
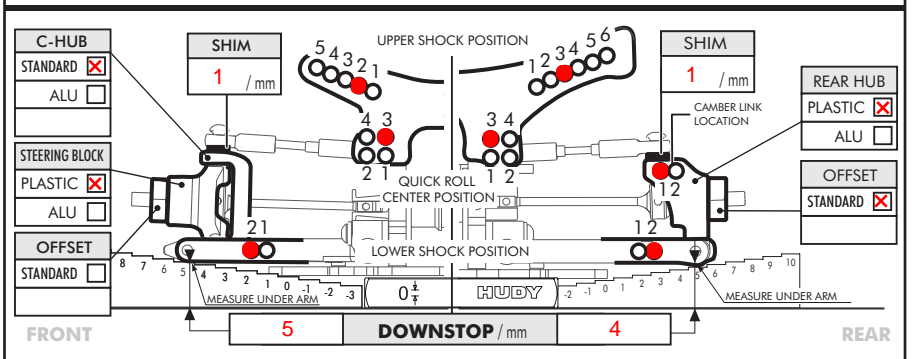
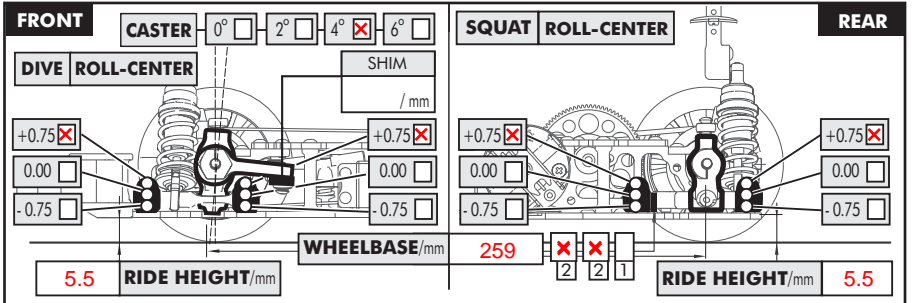

● - APPLIED S-SOFT M-MEDIUM H-HARD