

Driver **Tony McMahon** Track Surface **Indoor / Outdoor / Asphalt / Carpet** Track Temperature **10-20°C**  
 Date **23 May 2021** Track Traction **Low/Medium** Result **1st** Air Temperature **18°C**  
 Track **TFTR Melbourne** Country **Australia** Best Lap **15.97** Humidity \_\_\_\_\_ Remark \_\_\_\_\_

### Front

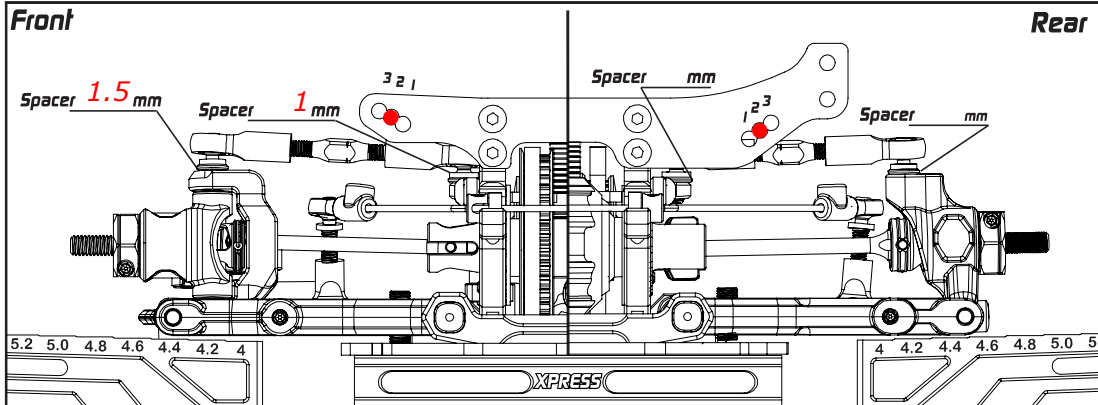

C-Hub	Suspension Arm	Hex Offset	<b>5 mm</b>	mm	Rear Hub	Suspension Arm
<input type="checkbox"/> M <input checked="" type="checkbox"/> H	<input checked="" type="checkbox"/> M <input type="checkbox"/> H	Camber	<b>2.5°</b>	mm	<input type="checkbox"/> M <input type="checkbox"/> H	<input type="checkbox"/> M <input type="checkbox"/> H
Steering Block		Ride Height	<b>5.0 mm</b>	mm		
<input type="checkbox"/> M <input checked="" type="checkbox"/> H		DownStop	<b>5.6 mm</b>	mm		
		Sway Bar	<b>1.3 mm</b>	mm		

### Optional On-Power Control System

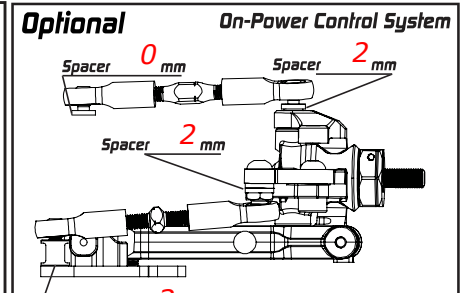

Hex Offset	<b>5 mm</b>	Steering Block	<input type="checkbox"/> M <input checked="" type="checkbox"/> H
Camber	<b>2.5°</b>	Suspension Arm	<input type="checkbox"/> M <input checked="" type="checkbox"/> H
Ride Height	<b>5.4 mm</b>		
DownStop	<b>4.8 mm</b>		
Sway Bar	<b>1.3 mm</b>		

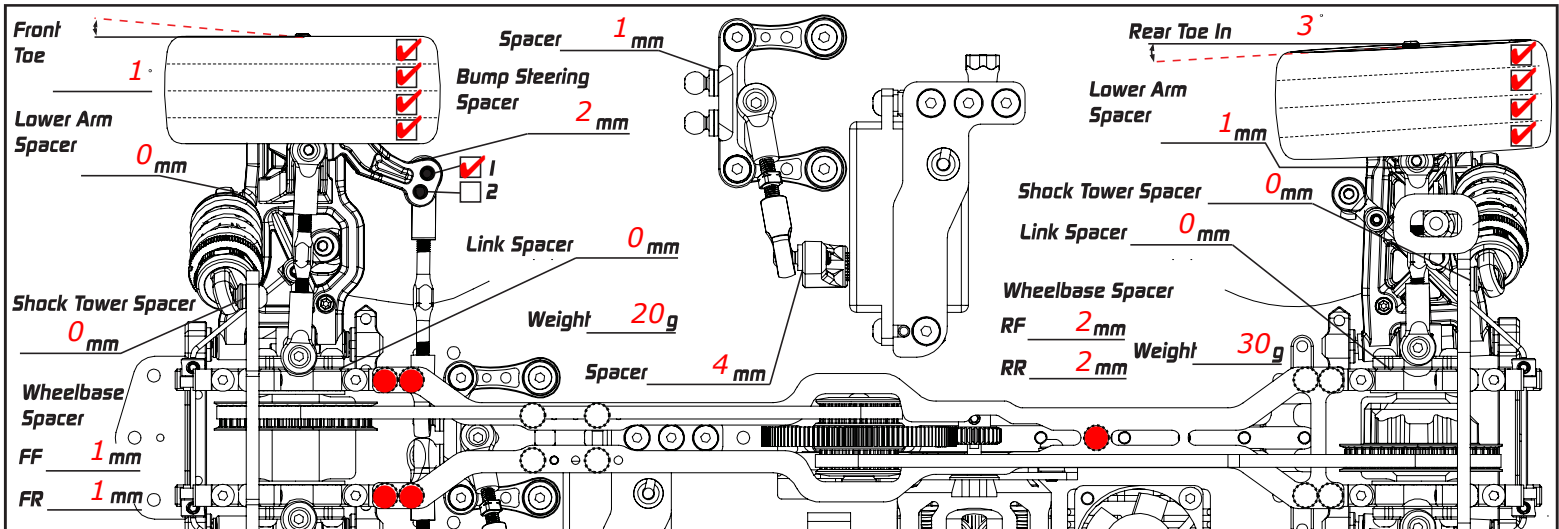

Front Toe **1°**  
 Lower Arm Spacer **0 mm**  
 Shock Tower Spacer **0 mm**  
 Wheelbase Spacer FF **1 mm**, FR **1 mm**  
 Bump Steering Spacer **2 mm**  
 Link Spacer **0 mm**  
 Weight **20 g**  
 Spacer **4 mm**  
 Rear Toe In **3°**  
 Lower Arm Spacer **1 mm**  
 Shock Tower Spacer **0 mm**  
 Link Spacer **0 mm**  
 Wheelbase Spacer RF **2 mm**, RR **2 mm**  
 Weight **30 g**

### Suspension Mount Setup

FF	FR
<input type="checkbox"/> I <input checked="" type="checkbox"/> Aluminium	<input type="checkbox"/> I <input type="checkbox"/> Aluminium <input checked="" type="checkbox"/> Spill
<input type="checkbox"/> 0.5 <input type="checkbox"/> Brass	<input checked="" type="checkbox"/> 0.5 <input type="checkbox"/> Brass <input type="checkbox"/> Solid
RR	RF
<input type="checkbox"/> I <input type="checkbox"/> Aluminium	<input type="checkbox"/> I <input type="checkbox"/> Aluminium <input type="checkbox"/> Spill
<input type="checkbox"/> 0.5 <input checked="" type="checkbox"/> Brass	<input checked="" type="checkbox"/> 0.5 <input type="checkbox"/> Brass <input type="checkbox"/> Solid

### Flex Control

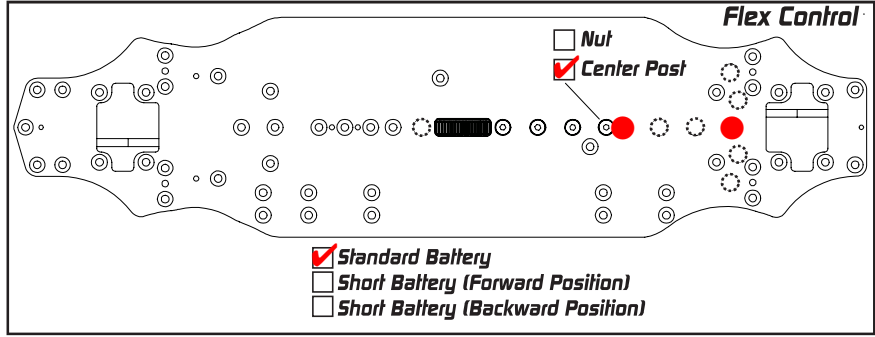

Nut  
 Center Post  
 Standard Battery  
 Short Battery (Forward Position)  
 Short Battery (Backward Position)

### Damper Setup

	Front	Rear
Spring	<b>xray 2.5/2.8</b>	<b>xray 2.5/2.8</b>
Oil	<b>500</b>	<b>500</b>
Rebound	<b>50%</b>	<b>50%</b>
Piston	<b>4</b>	<b>4</b>
Length	<b>8.5mm V2 Shocks</b>	<b>8.5mm V2 Shocks</b>
Foam Insert	<input type="checkbox"/>	<input type="checkbox"/>
Hole In Cap	<input type="checkbox"/>	<input type="checkbox"/>

### Transmission Setup

Front		Rear	
Gear Diff	Spool	Gear Diff	
		<b>3000</b>	
Oil		Oil	<b>3000</b>
Weight	<b>g</b>	Weight	<b>1.0 g</b>
Position	<b>low</b>	Position	<b>low</b>

### Servo/Tires/Motor

Servo	<b>MKS</b>	Tires	<b>KWR 36</b>
Esc	<b>HW</b>	Additive	<b>ATS</b>
Motor	<b>HW</b>	Body	<b>Speciale</b>
Spur	<b>64 p/ 98</b>	Rear Wing	<b>Kit, Forward</b>
Pinon	<b>64 p/ 40</b>	FDR	<b>4.67</b>