

Driver \_\_\_\_\_ Track Surface Indoor / Outdoor / Asphalt / Carpet Track Temperature \_\_\_\_\_  
 Date \_\_\_\_\_ Track Traction \_\_\_\_\_ Result \_\_\_\_\_ Air Temperature \_\_\_\_\_  
 Track \_\_\_\_\_ Country \_\_\_\_\_ Best Lap \_\_\_\_\_ Humidity \_\_\_\_\_ Remark \_\_\_\_\_

### Front

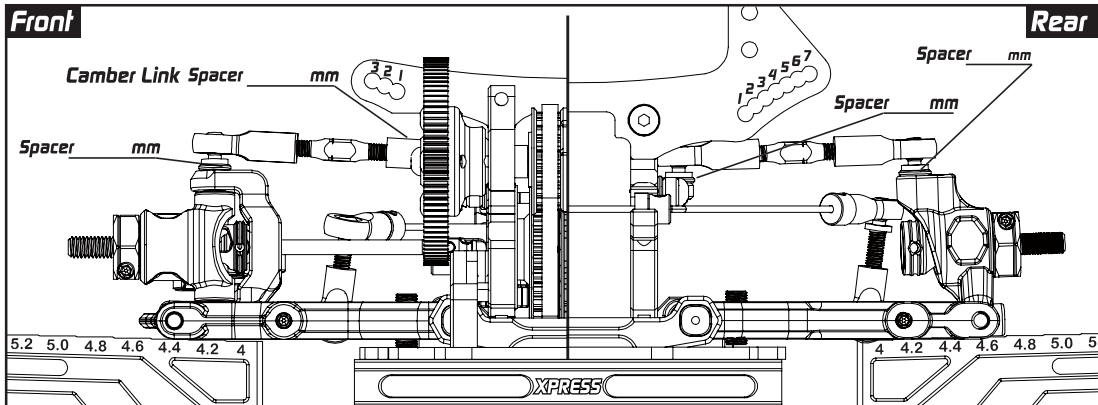

Labels: Camber Link Spacer mm, Spacer mm, Hex Offset mm, Camber mm, Ride Height mm, DownStop mm, Sway Bar mm, C-Hub M H, Steering Block M H, Suspension Arm M H.

### Rear

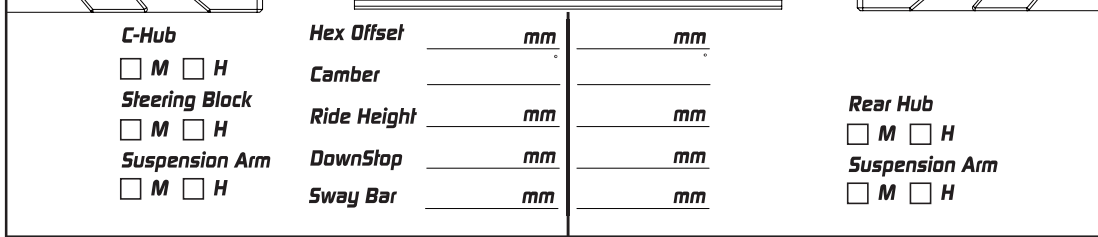

Labels: Spacer mm, Hex Offset mm, Camber mm, Ride Height mm, DownStop mm, Sway Bar mm, Rear Hub M H, Suspension Arm M H.

### Optional On-Power Control System

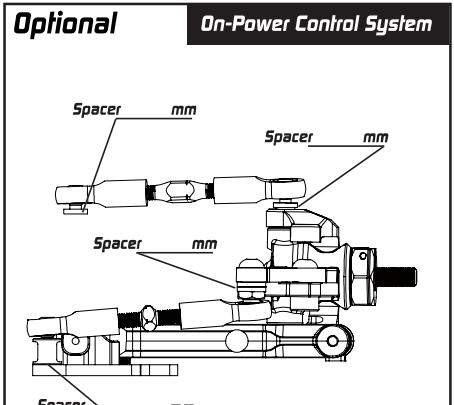

Labels: Spacer mm, Hex Offset mm, Camber mm, Ride Height mm, DownStop mm, Sway Bar mm, Steering Block M H, Suspension Arm M H.

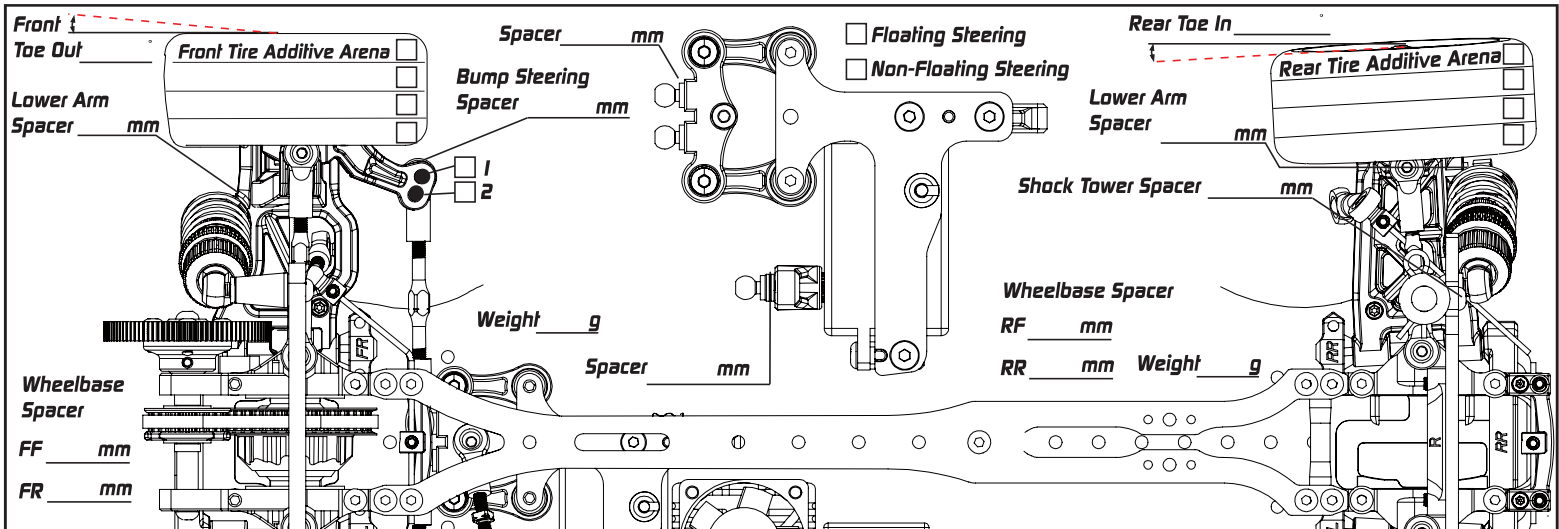

Labels: Front Toe Out, Front Tire Additive Arena, Lower Arm Spacer mm, Bump Steering Spacer mm, Weight g, Wheelbase Spacer FF mm, FR mm, Floating Steering, Non-Floating Steering, Rear Toe In, Rear Tire Additive Arena, Lower Arm Spacer mm, Shock Tower Spacer mm, Wheelbase Spacer RF mm, RR mm, Weight g.

### Suspension Mount Setup

FF:  1  Aluminium  0.5  Brass

FR:  1  Aluminium  Split  0.5  Brass  Solid

RR:  1  Aluminium  0.5  Brass

RF:  1  Aluminium  Split  0.5  Brass  Solid

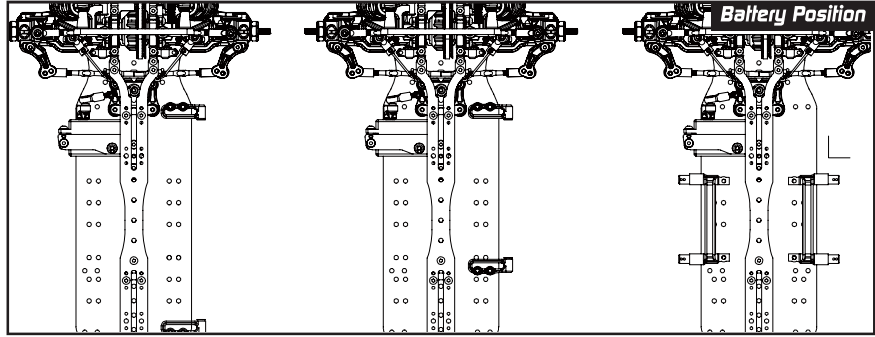

### Battery Position

### Damper Setup

	Front	Rear
Spring	_____	_____
Oil	_____	_____
Rebound	_____	_____
Piston	2 / 3 / 4	2 / 3 / 4
Length	_____	_____
Foam Insert	<input type="checkbox"/>	<input type="checkbox"/>
Hole In Cap	<input type="checkbox"/>	<input type="checkbox"/>

### Transmission Setup

Front

Gear Diff \_\_\_\_\_

Oil \_\_\_\_\_

Weight \_\_\_\_\_ g

Position \_\_\_\_\_

### Others

Servo \_\_\_\_\_ Tires \_\_\_\_\_

Esc \_\_\_\_\_ Additive \_\_\_\_\_

Motor \_\_\_\_\_ Body \_\_\_\_\_

Spur P/ T Rear Wing \_\_\_\_\_

Pinon P/ T FDR \_\_\_\_\_

### NOTES