

Driver _____ Track Surface Indoor / Outdoor / Asphalt / Carpet Track Temperature _____
 Date _____ Track Traction _____ Result _____ Air Temperature _____
 Track _____ Country _____ Best Lap _____ Humidity _____ Remark _____

Front

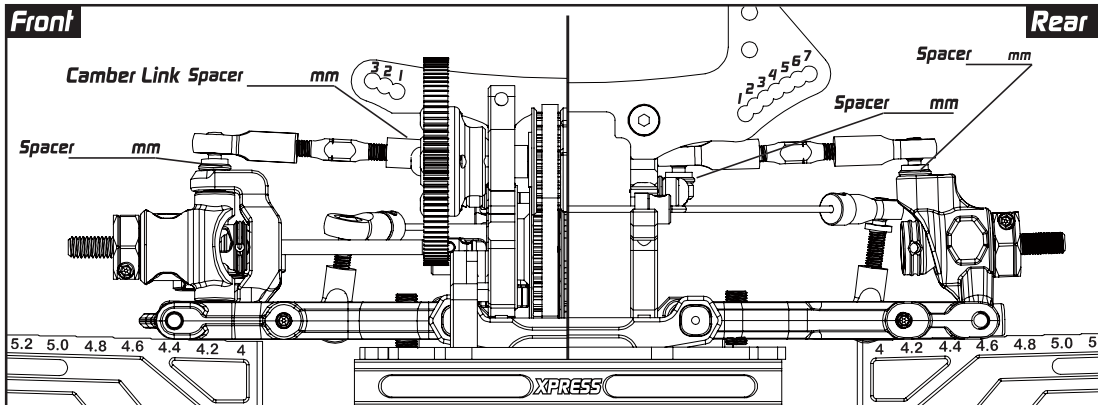

Labels: Camber Link Spacer mm, Spacer mm, Hex Offset mm, Camber, Ride Height mm, DownStop mm, Sway Bar mm, C-Hub M H, Steering Block M H, Suspension Arm M H.

Rear

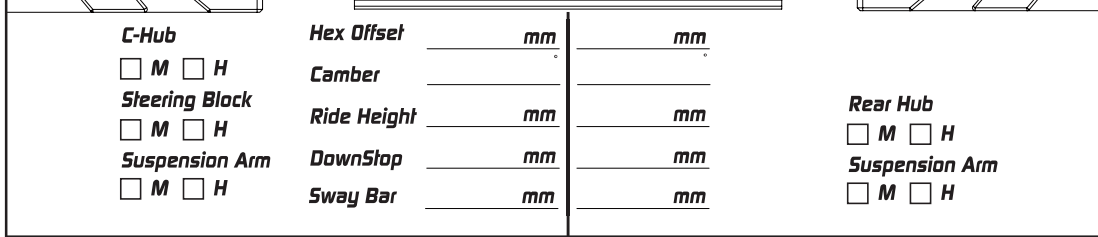

Labels: Spacer mm, Hex Offset mm, Camber, Ride Height mm, DownStop mm, Sway Bar mm, Rear Hub M H, Suspension Arm M H.

Optional On-Power Control System

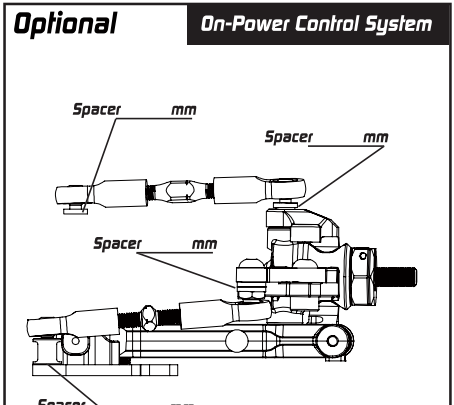

Labels: Spacer mm, Hex Offset mm, Camber, Ride Height mm, DownStop mm, Sway Bar mm, Steering Block M H, Suspension Arm M H.

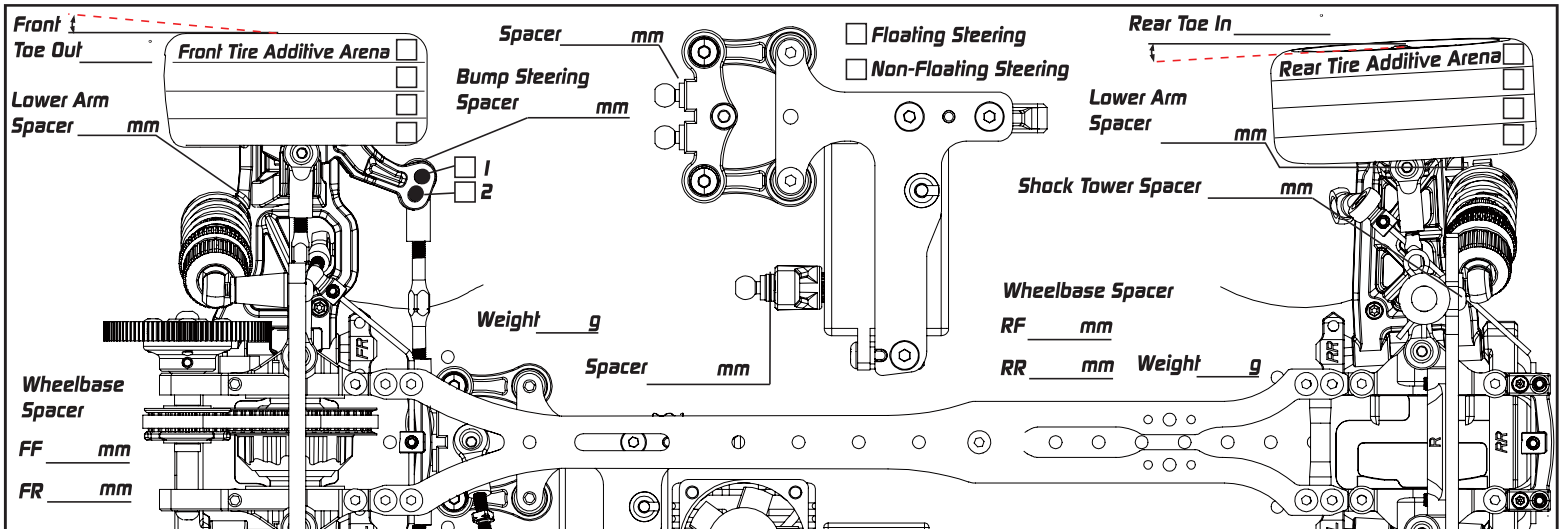

Labels: Front Toe Out, Front Tire Additive Arena, Lower Arm Spacer mm, Bump Steering Spacer mm, Weight g, Wheelbase Spacer FF mm, FR mm, Floating Steering , Non-Floating Steering , Rear Toe In, Rear Tire Additive Arena, Lower Arm Spacer mm, Shock Tower Spacer mm, Wheelbase Spacer RF mm, RR mm, Weight g.

Suspension Mount Setup

FF
 1 Aluminium Split
 0.5 Brass Solid

FR
 1 Aluminium Split
 0.5 Brass Solid

RR
 1 Aluminium Split
 0.5 Brass Solid

RF
 1 Aluminium Split
 0.5 Brass Solid

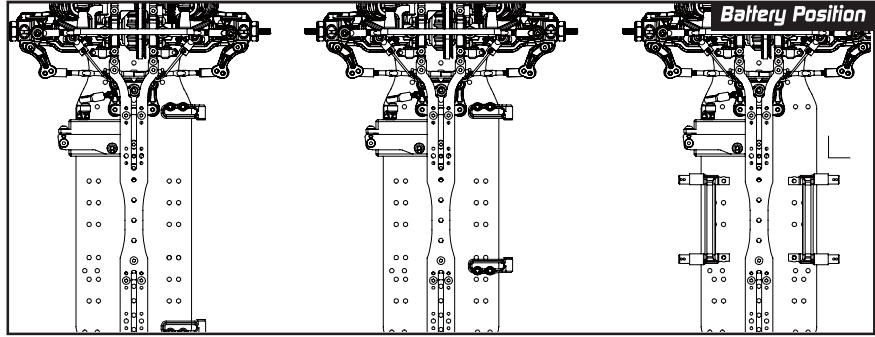

Battery Position

Damper Setup

	Front	Rear
Spring	_____	_____
Oil	_____	_____
Rebound	_____	_____
Piston	2 / 3 / 4	2 / 3 / 4
Length	_____	_____
Foam Insert	<input type="checkbox"/>	<input type="checkbox"/>
Hole In Cap	<input type="checkbox"/>	<input type="checkbox"/>

Transmission Setup

Front

Gear Diff _____

Oil _____

Weight _____ g

Position _____

Others

Servo _____ Tires _____

Esc _____ Additive _____

Motor _____ Body _____

Spur P/ T Rear Wing _____

Pinon P/ T FDR _____

NOTES