

F18.2

Driver: _____ Track: _____
 Date: _____ Event: _____

Composition: Asphalt Carpet _____
Surface: Bumpy Smooth _____
Layout: Open Mixed Tight _____
Traction: Low Medium High _____

Front
 Spring: _____
 Track width: _____
 Ride Height: _____
 Wheelbase: Short Long

Center
 Oil: _____
 Piston: _____
 Damper spring: _____
 Damper spring preload: _____
 Side Absorber lube: _____
 Side spring: _____
 Side spring preload: _____

Rear
 Differential: _____
 LOOSE TIGHT
 Track width: _____
 Ride height: _____
 -3 MM. -2 MM. -1 MM. 0 MM. +1 MM. +2 MM. +3 MM.

Tires
 Front: _____
 Treatment: _____
 Surface & time: _____
 Rear: _____
 Treatment: _____
 Surface & time: _____

Aerodynamics
 Body: _____
 Front wing: Kit _____
 Rear wing: Kit Carbone _____

Electronics
 Motor: _____
 Pinion / Spur: _____ Pitch: _____
 ESC: _____
 ESC setting: _____
 Battery: _____
 Servo: _____
 Radio: _____
 Receiver: _____

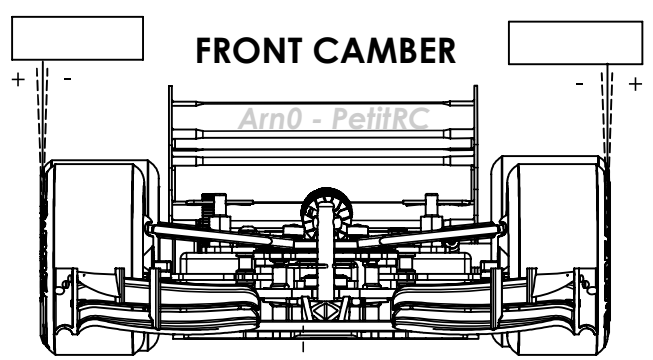
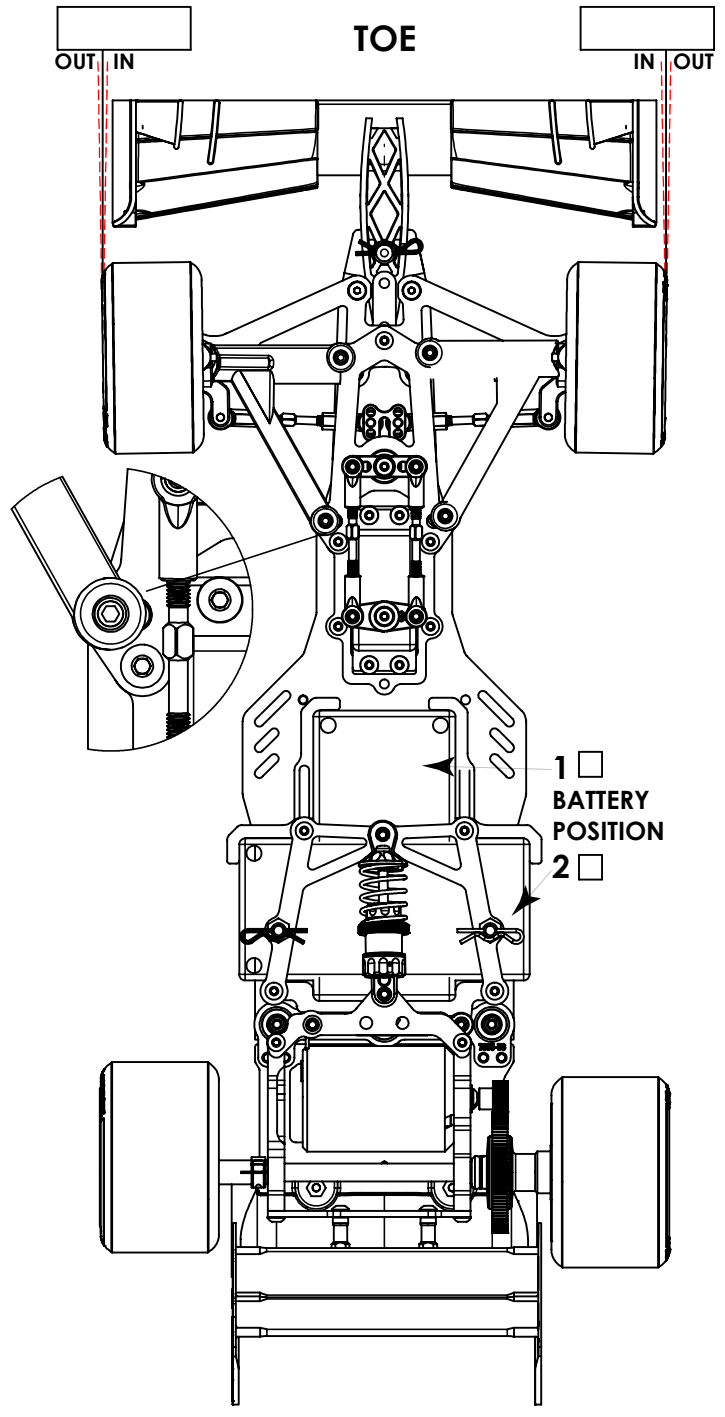
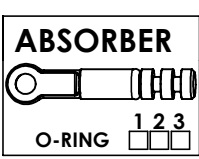
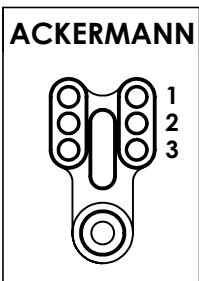
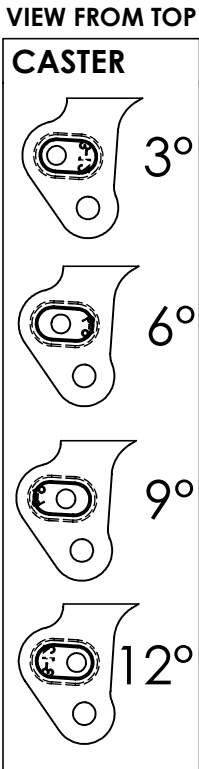
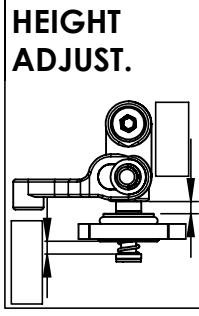

Comments

