

WILDFIRE DO6

1/10 4WD ELECTRIC COMPETITION TOURING CAR KIT



SETUP SHEET

DRIVER	DATE
TRACK NAME	RESULT
COMPOSITION	(INDOOR/OUTDOOR) BEST LAP
HUMIDITY	TRACK TEMP
GRIP HI MEDIUM LOW	SURFACE SMOOTH BUMPY

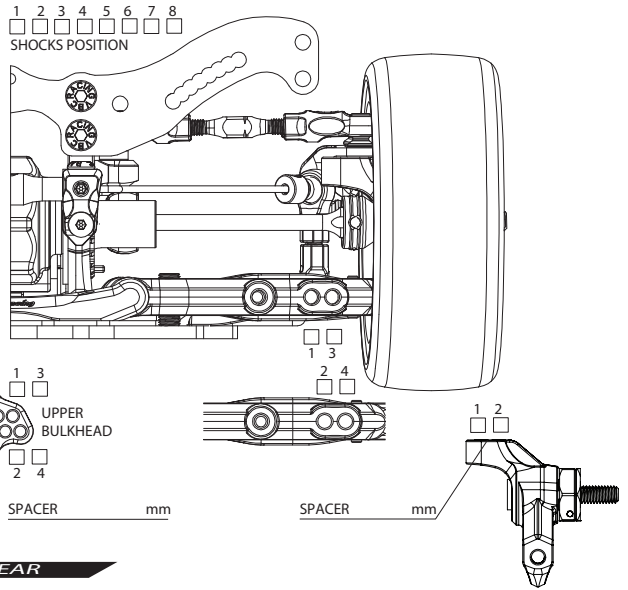
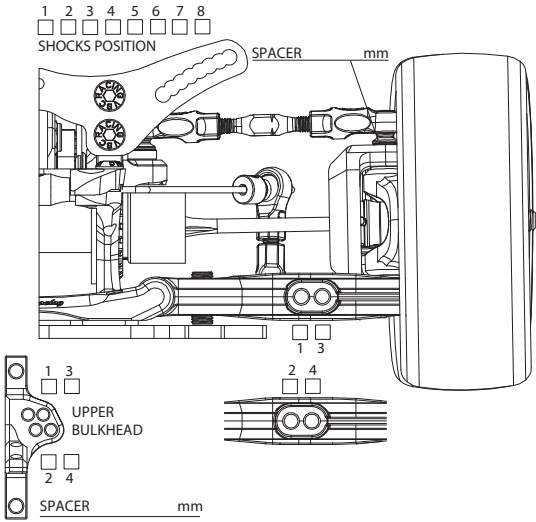

FRONT

GROUND CLEARANCE _____ mm DROOP _____

CAMBER ANGLE _____ ° TOE ANGLE _____ °

CASTER BLOCK _____ ° FRONT DRIVE DIFF (OIL _____) / DIRECT _____

STABILIZER 1.2 1.3 1.4 WHEEL SPACER _____ mm

SUSPENSION SHIM (FF) _____ mm SUSPENSION SHIM (FR) _____ mm

SUSPENSION MOUNT (FF) _____ SUSPENSION MOUNT (FR) _____

WHEELBASE FRONT _____ REAR _____ BELT TENSION _____

AXLE TYPE / SIZE TWO PIECE JOINT / SINGLE JOINT (STEEL/ALUM) _____ mm

REAR

GROUND CLEARANCE _____ mm DROOP _____

CAMBER ANGLE _____ ° TOE ANGLE _____ °

REAR DRIVE DIFF (OIL _____) DRIVE CUP _____ ALUMINUM/STEEL _____

STABILIZER 1.2 1.3 1.4 WHEEL SPACER _____ mm

SUSPENSION SHIM (RF) _____ mm SUSPENSION SHIM (RR) _____ mm

SUSPENSION MOUNT (RF) _____ SUSPENSION MOUNT (RR) _____

WHEELBASE FRONT _____ REAR _____ BELT TENSION _____

AXLE TYPE / SIZE TWO PIECE JOINT / SINGLE JOINT (STEEL/ALUM) _____ mm

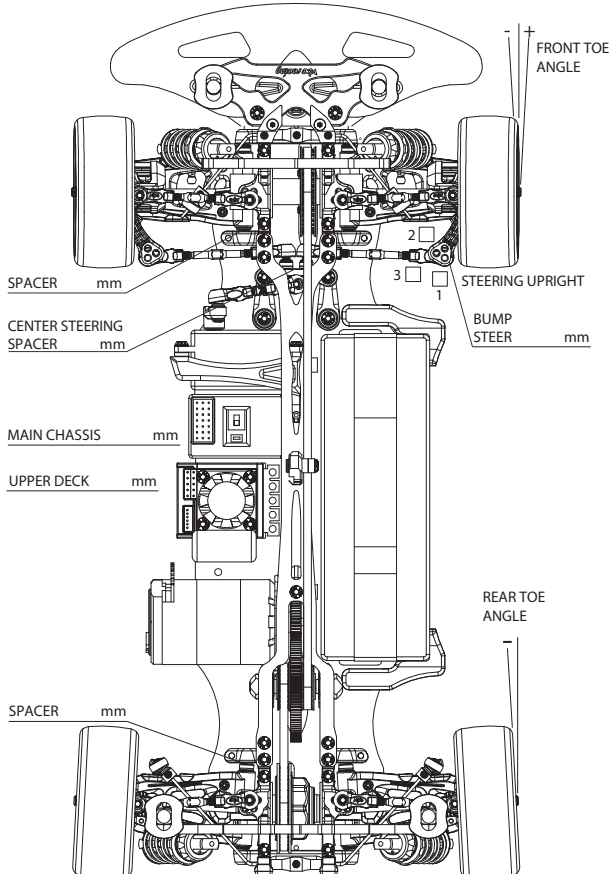

FRONT

SHOCK LENGTH _____ mm

PISTON 3 4 holes / OTHERS _____

OIL _____

SPRING _____

OIL SEALER CAP S / MS / M / H _____

REBOUND _____ %

NOTES _____



REAR

SHOCK LENGTH _____ mm

PISTON 3 4 holes / OTHERS _____

OIL _____

SPRING _____

OIL SEALER CAP S / MS / M / H _____

REBOUND _____ %

NOTES _____

MOTOR _____ SPUR _____ T _____ PINION _____ T _____ PITCH _____

TIRE _____ TIRE INSERT _____ WHEEL _____

TIRE ADDICTIVE _____ TIME _____ TIRE WARMER _____

ESC _____ ESC SETTING _____

BATTERY _____ BODY _____ REAR WING _____

REMARKS _____
