

WILDFIRE

1/10 4WD ELECTRIC COMPETITION TOURING CAR KIT

vbc racing

DRIVER Wong Kok Wai DATE 24 Feb 2013

TRACK NAME TITC 2013, RC Addict RESULT _____

TRACK SURFACE Asphalt GRIP CONDITION HI MED LOW

HUMIDITY _____ TRACK TEMP 65C

SETUP SHEET

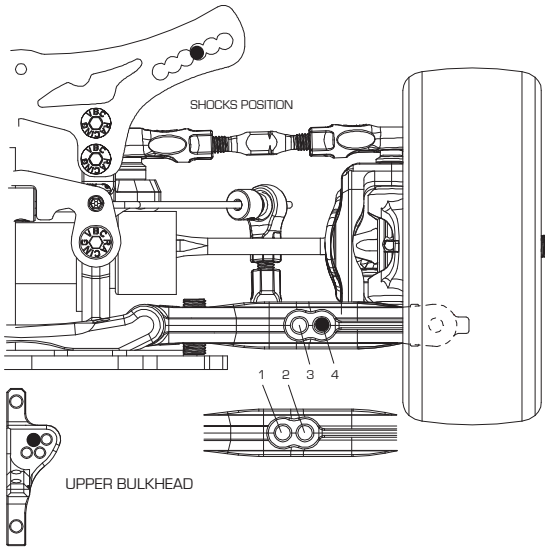

FRONT

| | | | |
|-----------------------------|--------------------|----------------------------|---------------|
| GROUND CLEARANCE | <u>4.5</u> mm | REBOUND | <u>4</u> mm |
| CAMBER ANGLE | <u>-1.5</u> ° | TOE ANGLE | <u>-1</u> ° |
| CASTER BLOCK | ° | FRONT DRIVE DIFF (OIL) | <u>DIRECT</u> |
| STABILIZER | 1.2 <u>1.3</u> 1.4 | WHEEL SPACER | <u>0.5</u> mm |
| FRONT SUSPENSION MOUNT SHIM | <u>0.5</u> mm | REAR SUSPENSION MOUNT SHIM | <u>0.5</u> mm |
| FRONT SUSPENSION MOUNT | <u>F10</u> | REAR SUSPENSION MOUNT | <u>C0</u> |
| DOWNSTOP | <u>5.5</u> mm | | |

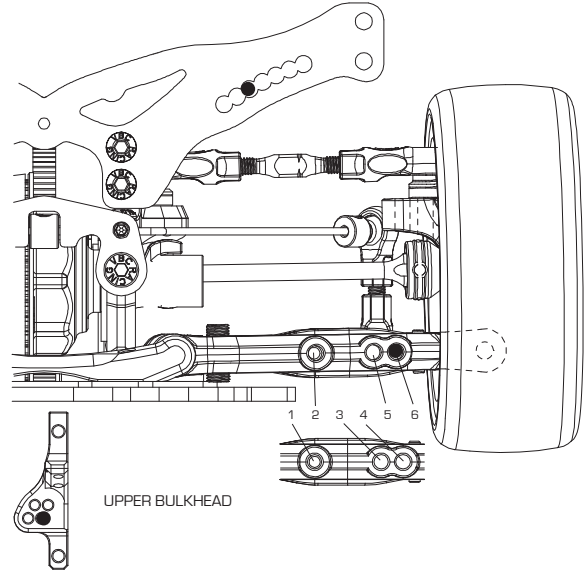

REAR

| | | | |
|-----------------------------|--------------------|----------------------------|----------------|
| GROUND CLEARANCE | <u>5</u> mm | REBOUND | <u>4</u> mm |
| CAMBER ANGLE | <u>-1.5</u> ° | TOE ANGLE | <u>1.5</u> ° |
| | | FRONT DRIVE DIFF (OIL) | <u>4000cst</u> |
| STABILIZER | 1.2 <u>1.3</u> 1.4 | WHEEL SPACER | <u>0</u> mm |
| FRONT SUSPENSION MOUNT SHIM | <u>1</u> mm | REAR SUSPENSION MOUNT SHIM | <u>1</u> mm |
| FRONT SUSPENSION MOUNT | <u>C0</u> | REAR SUSPENSION MOUNT | <u>E15</u> |
| DOWNSTOP | <u>5.3</u> mm | | |

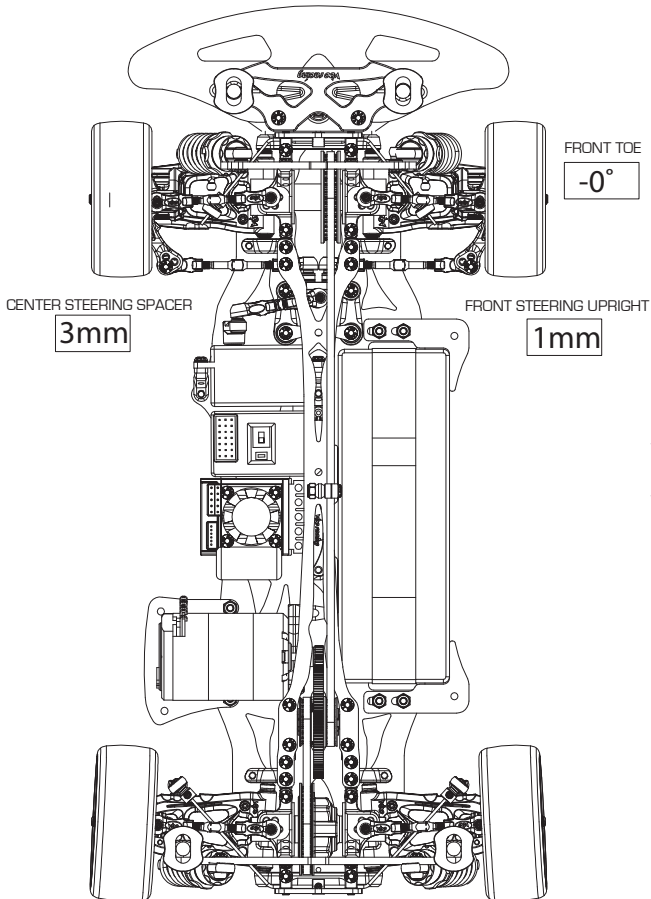

FRONT

| | |
|--------------|----------------------|
| SHOCK LENGTH | <u>64</u> mm |
| PISTON | 1 2 <u>3</u> hole(s) |
| OIL | <u>350</u> |
| SPRING | <u>VBC Orange</u> |



REAR

| | |
|--------------|----------------------|
| SHOCK LENGTH | <u>64</u> mm |
| PISTON | 1 2 <u>3</u> hole(s) |
| OIL | <u>350</u> |
| SPRING | <u>VBC Red</u> |

| | | | | | |
|----------------|--|-------------|--------------|---------|--|
| MOTOR | <u>13.5T ORCA</u> | SPUR | | PINION | |
| TIRE | <u>Ride 26006</u> | TIRE INSERT | | WHEEL | |
| TIRE ADDICTIVE | <u>LRP</u> | BODY | <u>LTC-R</u> | BATTERY | |
| REMARKS | <u>TITC 2013 Open Brushless 13.5 - Finished B8</u> | | | | |
