



1/10 SCALE ELECTRIC COMPETITION FORMULA CAR KIT



DRIVER \_\_\_\_\_ DATE \_\_\_\_\_  
 TRACK \_\_\_\_\_ RESULT \_\_\_\_\_  
 ASPHALT / CARPET INDOOR / OUTDOOR BEST LAP \_\_\_\_\_  
 HUMIDITY \_\_\_\_\_ TRACK TEMP \_\_\_\_\_ AIR TEMP \_\_\_\_\_  
 GRIP LOW MEDIUM HIGH SURFACE BUMPY MEDIUM SMOOTH

**SETUP SHEET**

Am0

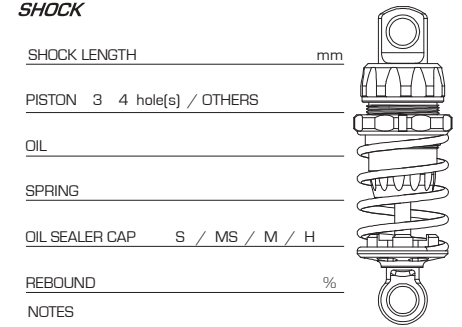
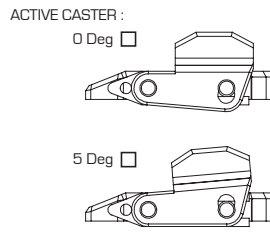
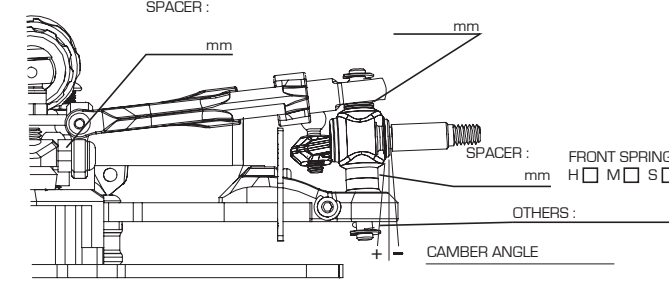
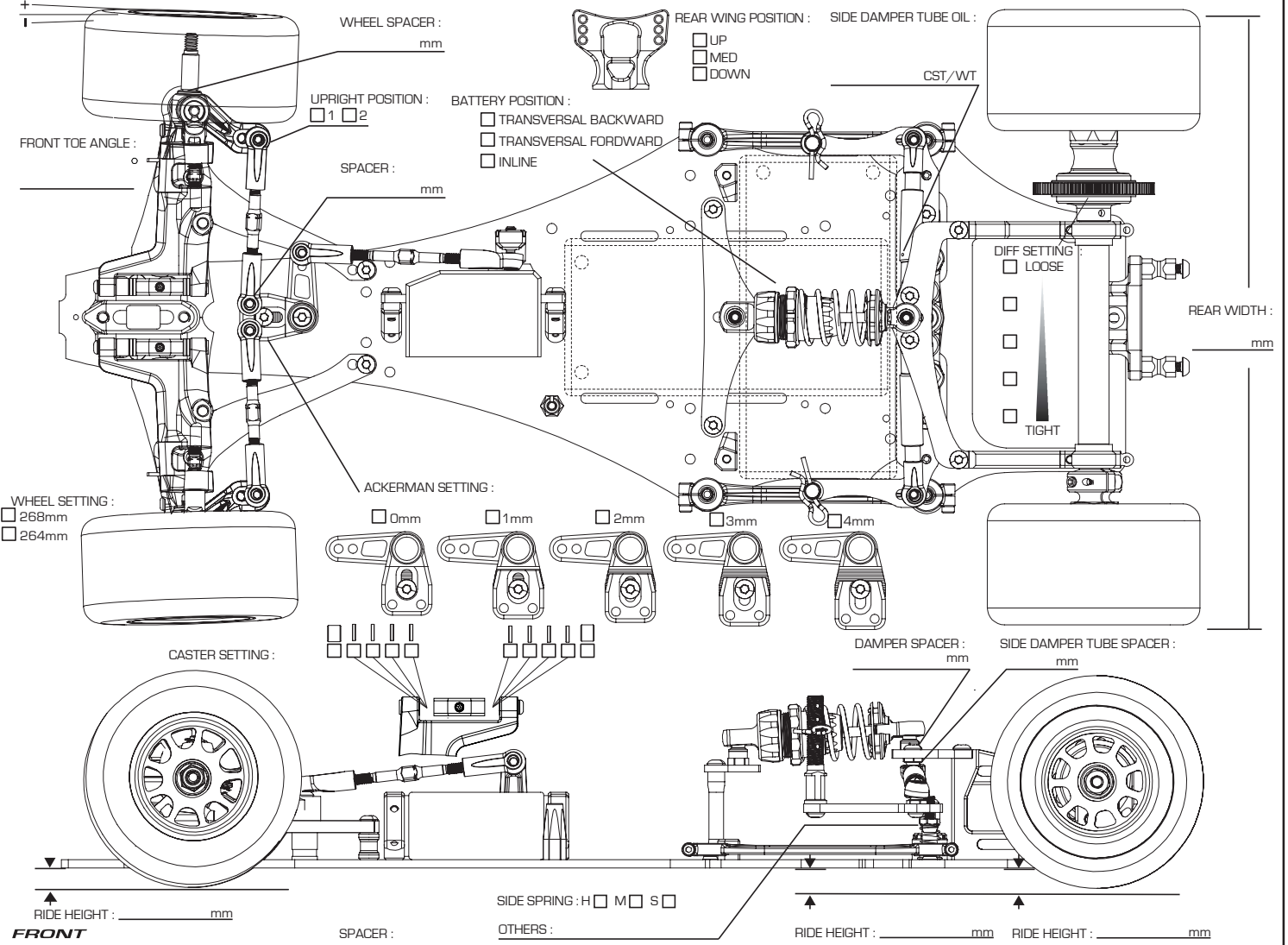

**FRONT TIRES**  
 TIRE: \_\_\_\_\_  
 DIAMETER: \_\_\_\_\_ mm  
 WHEEL: \_\_\_\_\_  
 TIRE TREATMENT: \_\_\_\_\_  
 TREATMENT TIME: \_\_\_\_\_  
  
 SURFACE TREATED: \_\_\_\_\_  
 NOTES: \_\_\_\_\_

**REAR TIRES**  
 TIRE: \_\_\_\_\_  
 DIAMETER: \_\_\_\_\_ mm  
 WHEEL: \_\_\_\_\_  
 TIRE TREATMENT: \_\_\_\_\_  
 TREATMENT TIME: \_\_\_\_\_  
  
 SURFACE TREATED: \_\_\_\_\_  
 NOTES: \_\_\_\_\_

**REAR AXLE**  
  
 1mm \_\_\_\_\_ pcs  
  
 0.5mm \_\_\_\_\_ pcs  
 MOTOR: \_\_\_\_\_ ROTOR: \_\_\_\_\_ TIMING: \_\_\_\_\_  
 SPUR: T \_\_\_\_\_ PINION: T \_\_\_\_\_ PITCH \_\_\_\_\_ ROLLOUT: \_\_\_\_\_  
 ESC: \_\_\_\_\_ SETUP: \_\_\_\_\_ BATTERY: \_\_\_\_\_  
 STEERING EXPO: \_\_\_\_\_ BRAKE E.P.: \_\_\_\_\_ THROTTLE EXPO: \_\_\_\_\_  
 BODY: \_\_\_\_\_ FRONT WING: \_\_\_\_\_ REAR WING: \_\_\_\_\_  
 WEIGHT: \_\_\_\_\_ REMARKS: \_\_\_\_\_