

TRF 419 WORLD CHAMPION TEAM

TAMIYA RACING FACTORY

SETTING SHEET

Name **Ed Clark** Date **09 Aug 15** Air temp. **12** Humidity **30**
 Track **IMCC - Open Layout** Track condition **Low - Med grip** Track temp. **16**

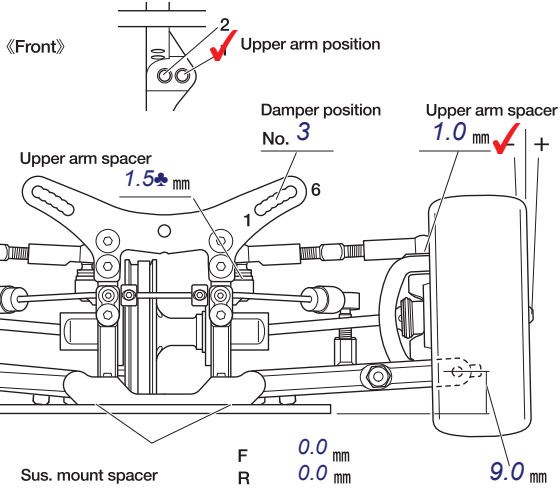

| | |
|------------------|---------------|
| Front axle | 4° |
| Camber angle | -1.5° |
| Ground clearance | 5.2 mm |
| Rebound stroke | 3 mm |
| Stabilizer | Black (1.3mm) |
| Wheel spacer | 0.5 mm |
| Front drive | Spool |
| Differential oil | # % |

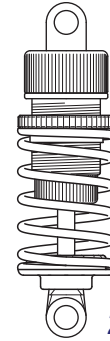

| | |
|-------------|-------------------|
| Damper type | TRF419 |
| Piston | 3 x 1.1mm hole(s) |
| Oil | MuchMore 450 # |
| Spring | Schumacher Green |

2x Blue Comp. O-rings in bottom of shocks F&R.
 2:2 Motor mount screws, set screws in open holes.

Memo

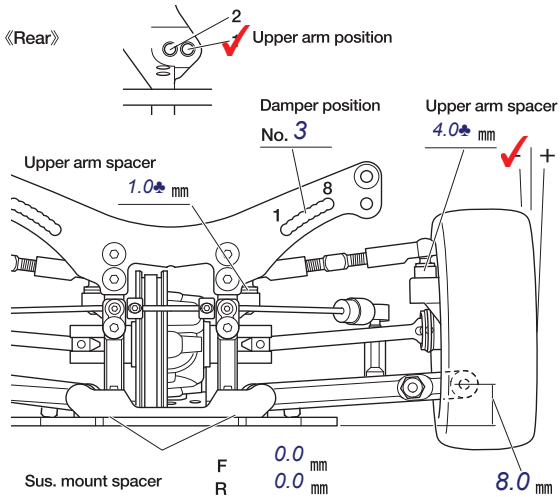

| | |
|------------------|---------------|
| Rear upright | 416 / 8 |
| Camber angle | -2.0° |
| Ground clearance | 5.4 mm |
| Rebound stroke | 3 mm |
| Stabilizer | Yokomo 1.2mm |
| Wheel spacer | 0.5 mm |
| Rear drive | Gear Diff |
| Differential oil | MuchMore 5000 |

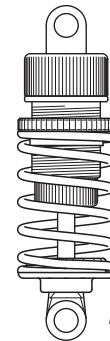

| | |
|-------------|-------------------|
| Damper type | TRF419 |
| Piston | 3 x 1.1mm hole(s) |
| Oil | MuchMore 450 # |
| Spring | Schumacher Green |

Droop to hinge pin centre.
 Roll bar in outer arm hole.
 ♦ H5 ballstud, ♣ Std ballstud
 ESC- 3,3,0,1,0,1,3,2,0,1

Memo

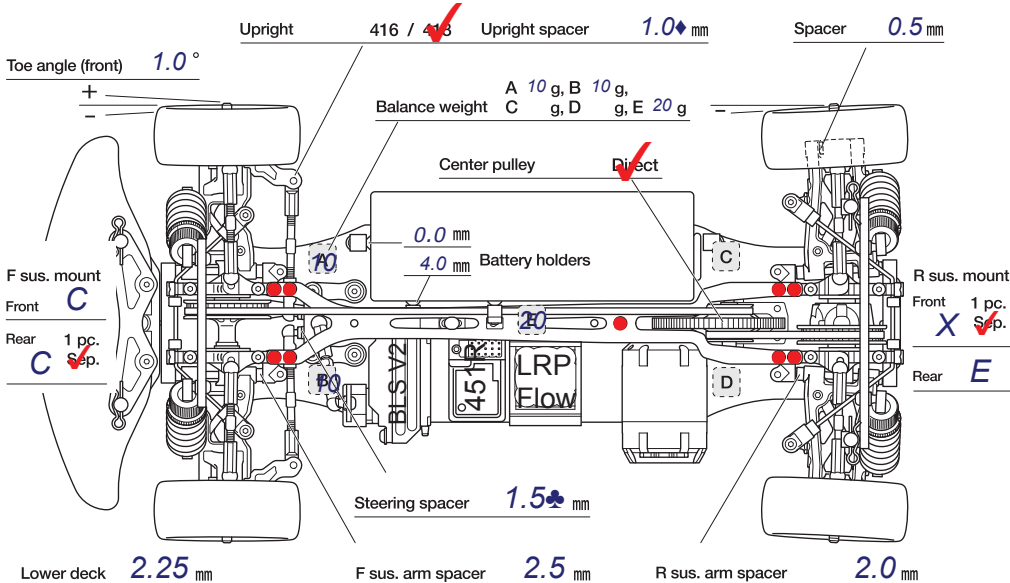

| | | | |
|-------------|----------------------------|-----------------------|----|
| Motor | LRP X20 4.5t - 4.7firmware | | |
| Spur | Pinion 86 _T | Pitch 20 _T | 48 |
| Battery | ProAmps 6000, 300 g | | |
| Body | LTC-R lwt | | |
| Wing | MR33 | | |
| Tire | Volante 36 V5T | | |
| Wheel | Volante | | |
| Tire insert | Volante | | |
| Best lap | | | |