

TRF 419 WORLD CHAMPION TEAM

TAMIYA RACING FACTORY

SETTING SHEET

Name **Ed Clark** Date **08Mar15** Air temp. **22** Humidity **50**
 Track **IMCC** Track condition **Low-Med grip** Track temp. **30**

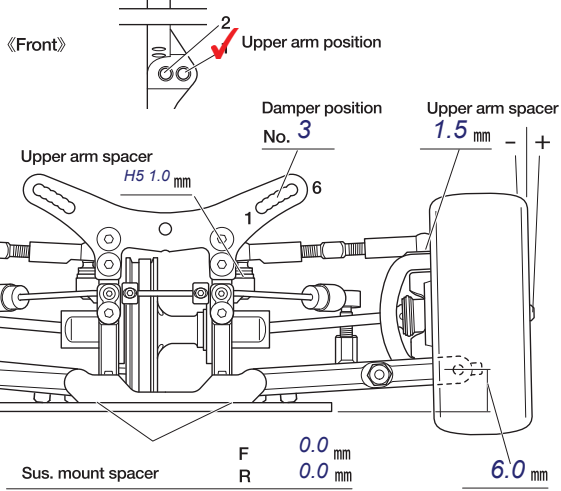

Front axle	4°
Camber angle	-1.5°
Ground clearance	5.2 mm
Rebound stroke	3 mm
Stabilizer	Black (1.3mm)
Wheel spacer	0.5 mm
Front drive	Spool
Differential oil	# %

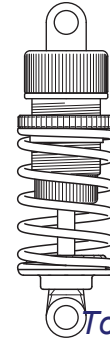

Damper type	419 Type
Piston	3 x 1.1mm hole(s)
Oil	MuchMore 450 #
Spring	Schumacher Green

Memo **To test next; Longer F w/b (2.5mm) + more Ackerman Lower out rear hub link shim**

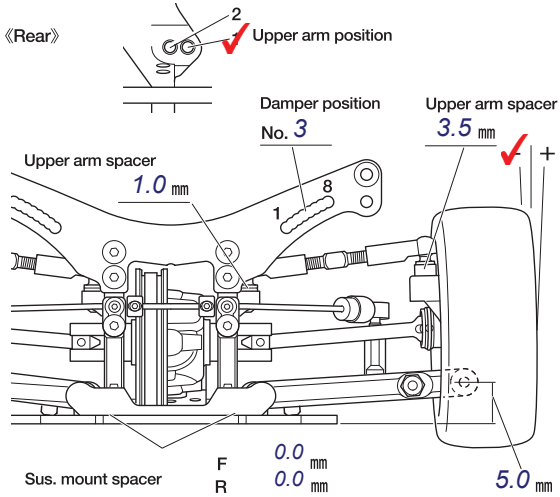

Rear upright	416 / <input checked="" type="checkbox"/> 8
Camber angle	-2.0°
Ground clearance	5.4 mm
Rebound stroke	3 mm
Stabilizer	Black (1.2mm)
Wheel spacer	0.5 mm
Rear drive	Gear Diff
Differential oil	MuchMore 5000

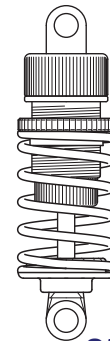

Damper type	419 Type
Piston	3 x 1.1mm hole(s)
Oil	MuchMore 450 #
Spring	Schumacher Green

Memo **Single screws in motor mount**

