



Setup Sheet



Name: _____ Date: _____ Event: _____

Track: _____ Track Condition: _____ Lap Time: _____ Final Position: _____

Front

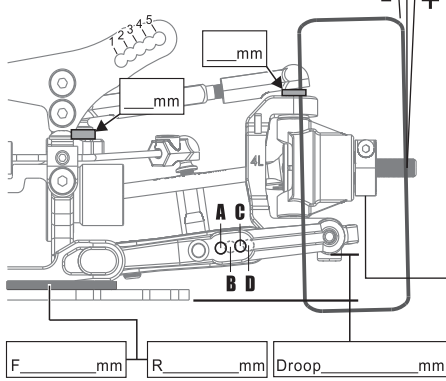

Camber Angle +/- _____°	Front Diff <input type="checkbox"/> Gear <input type="checkbox"/> Spool
Caster Angle _____°	Diff Oil # _____
Ride Height _____ mm	
Sway Bar Ø _____ mm	
Wheel Hubs _____ mm	
Spacer _____ mm	

Shocks

Shock Oil # _____

Piston 1.1 / 1.2 _____

O-ring _____

Rebound _____

Spring _____

Length _____ mm

A.R.T. SYSTEM

Active Rear Toe System

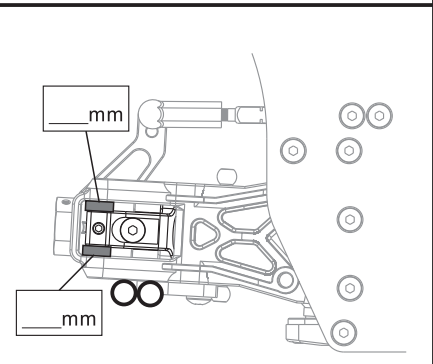
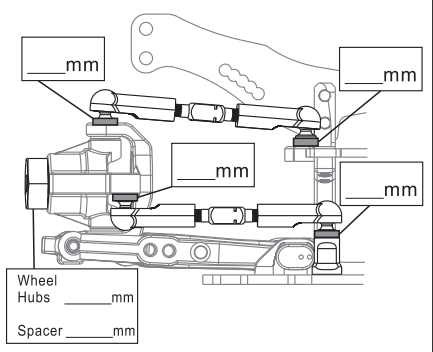

Rear

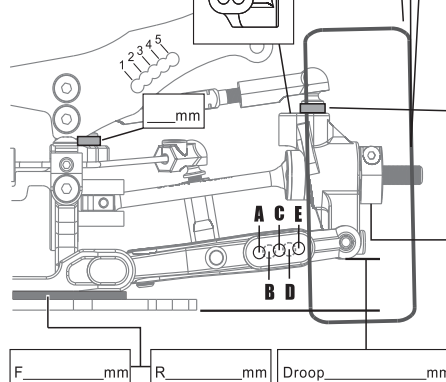

Camber Angle +/- _____°	Rear Diff Oil # _____
Ride Height _____ mm	
Shim _____ mm	
Sway Bar Ø _____ mm	
Wheel Hubs _____ mm	
Spacer _____ mm	

Shocks

Shock Oil # _____

Piston 1.1 / 1.2 _____

O-ring _____

Rebound _____

Spring _____

Length _____ mm

Chassis

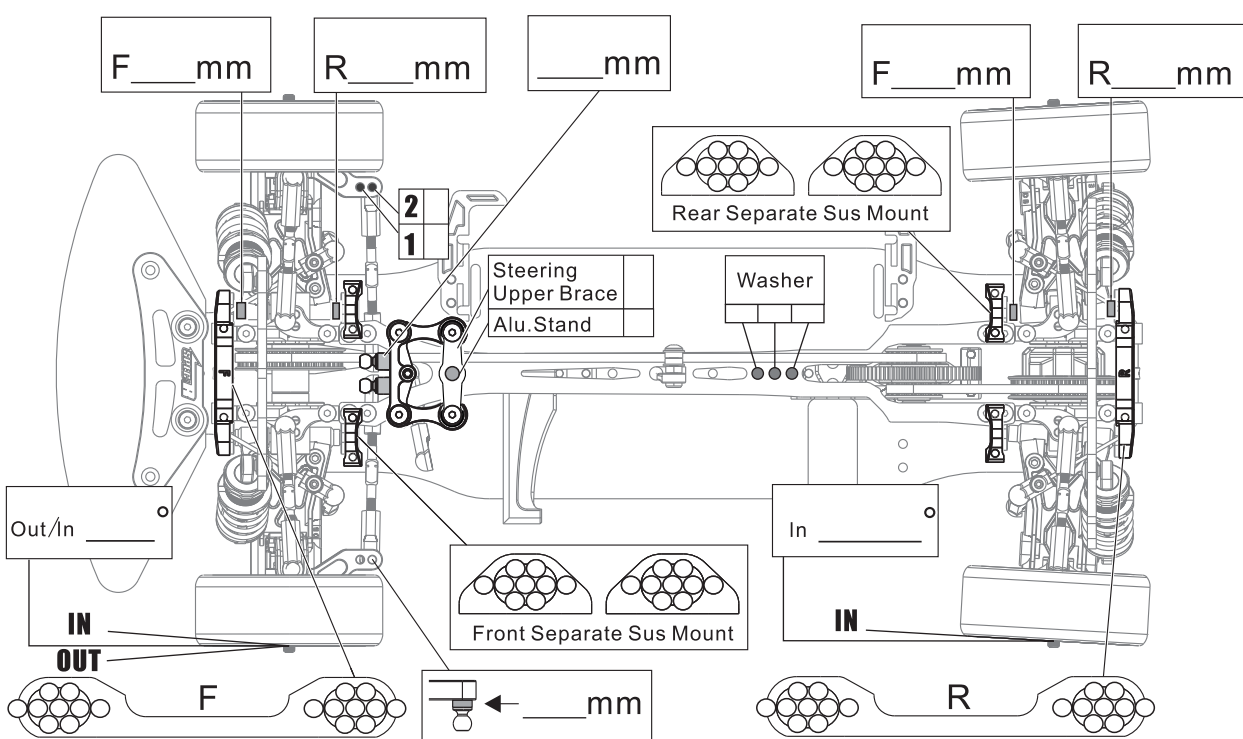

Tires

Brand: _____

Compound: _____

Insert: _____

Wheel: _____

Others

Motor: _____

Spur Gear: _____

Pinion Gear: _____

Battery: _____

ESC: _____

Body: _____

Wing: _____

	Front			Rear		
	Soft	Hard	Alu.	Soft	Hard	Alu.
C-Hub						
Steering Block						
Rear-Hub						
Arm						

Note: _____