

# X26

1/10 SCALE ELECTRIC TOURING CAR

INSTRUCTION  
MANUAL

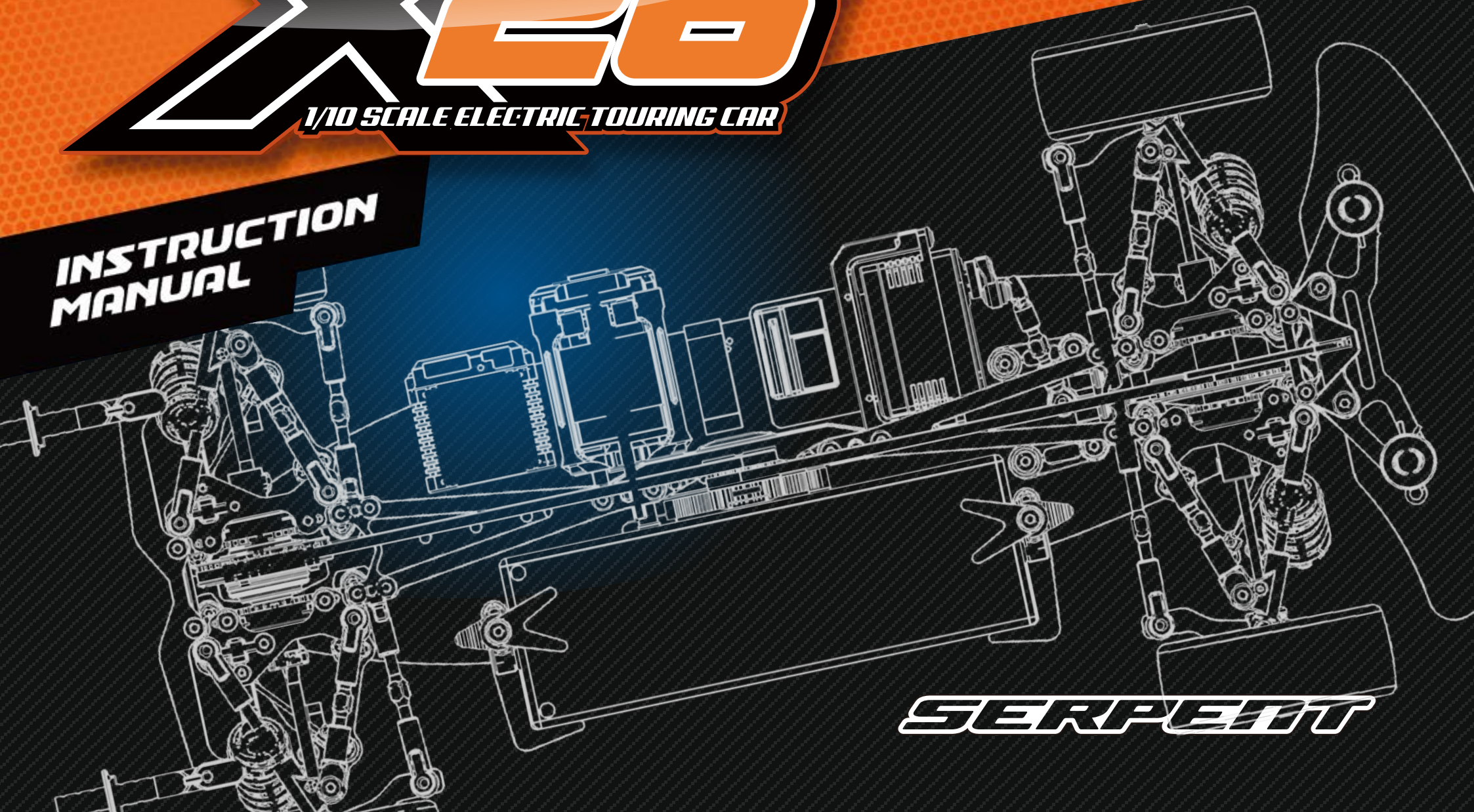

SERPENT

## INTRODUCTION

Thank you very much for selecting this Serpent rc car and thus become a member of the ever growing worldwide Serpent racing family. Serpent started in 1980 and has been growing its product-line and fan-base ever since.

The Serpent X26 mEdius is a state of the art 1/10 scale 4WD touringcar which will give you the true Serpent racing experience. The assembly manual will guide you through all the steps to complete the car, so you can hit the track with a good base-set-up soonest. The Serpent design department succeeded to create a superbly performing car combined with eas of assembly and maintenance. The high quality standards of all parts and hardware will make racing your Serpent car a very rewarding activity!

Through our team, website and social media we will keep you up-to-date on all developments of the Serpent cars. We hope to meet you on the track and through our various media! Enjoy the drive!

Team Serpent  
Multiple World Champions

## INSTRUCTIONS

Serpent's long tradition of excellence extends to the instruction manuals, and this instruction manual is no exception. The easy-to-follow layout is richly illustrated with 3D-rendered full-color images to make your building experience quick and easy. Following the instructions will result in a well-built, high-performance race-car that will soon be able to unleash its full potential at the racetrack. The kit includes bags, with bagnumbers, which refer to the same step in the manual. Open only the indicated bag(s) per step and finish that part of the assembly. Remaining parts will be needed lateron in the assembly process.

## PLASTIC PARTS

The Serpent moulded parts are very durable and hard. When assembling longer screws in new composite parts, make sure to use new hex bits in your (power) tools. Pre-threading also helps to avoid screw damage.

## SETUP

In certain assembly steps you need to make basic adjustments, which will give you a good initial setup for your Serpent X26 mEdius Fine-tuning the initial setup is an essential part of building a high-performance racecar like your Serpent

## EXPLODED VIEWS AND PARTS LIST

The exploded views and parts lists for the X26 mEdius are presented in the Reference Guide section in the back of this manual. The exploded views show all the parts of a particular assembly step along with the Serpent part number and hotlink to the Serpent website. Partnumbers in orange indicates that this part is an optional. Optionals part names and numbers are showed below.

## CUSTOMER SERVICE

Serpent has made a strong effort to make this manual as complete and clear as possible. Additional info may be published in our website: [www.serpent.com](http://www.serpent.com) or you may ask your dealer or the Serpent distributor for advice, or email Serpent direct: [info@serpent.com](mailto:info@serpent.com). The Serpent Facebook, Twitter and Youtube pages give additional means of support and communications.

## SAFETY

Read and take note of the 'Read this First section' before proceeding to assemble the car-kit. This car-kit is intended for persons aged 16 or older.

## READ THIS FIRST!

- This is a highly technical hobby product, intended to be used in a safe racing environment. This car is capable of speeds in excess of 80 km/h or 50mph. Please follow these guidelines when building and operating this model.
- Parental guidance is required when the builder/user of this car is under 16.
- Follow the building instructions. If in doubt, contact your dealer or importer.
- Be sure to use the proper tools when assembling the car. Always exercise caution when using electric tools, knives and other sharp objects.
- Be careful when using liquids like lubrication oil, fuel or glue. Do not swallow.
- Follow the manufacturer's instruction in case you experience irritation after using the product.
- Be careful when operating the car. Stay away from any rotating parts such as wheels, gears and transmission. Stay away from motor, engine and exhaust pipe system or speedo during and immediately after use, as these parts may be very hot. We advise to use protective hand cloves.
- Only operate this car in a safe environment, like a special racing track or a closed parking lot. Avoid using this car on public roads, crowded places or near infants.
- Before operating this car, always check the mechanical status of the car. Also check that the transmitter and receiver frequencies correspond and are not used by any other racer at the same time. Check that the batteries of the transmitter and receiver- are fully charged.
- After use, always check all the mechanics of the car. We advise to clean the car immediately after use, and inspect the parts for wear or fractures. Replace when necessary. Do not use water, methanol, thinner or other solvents to clean the car.
- Empty the fuel tank (depending on model) if needed and disconnect the receiver battery.
- Store the car in a dry and heated place to avoid corrosion of metal parts.
- Avoid using this car in wet conditions as the water will cause corrosion on the metal parts and bearings and these parts will cease to function properly. If driven in the wet, ensure that all the electric equipment is waterproofed and after use, that all moving parts are dried immediately.

## CONTENTS

• DIFF ASSEMBLY.....	4
• SOLID AXLE ASSEMBLY.....	5
• DJC ASSEMBLY.....	6
• CVD ASSEMBLY.....	7
• CHASSIS.....	8
• FRONT & REAR ASSEMBLY.....	9
• MOTORMOUNT/TRANSMISSION ASSEMBLY.....	14
• REAR ASSEMBLY.....	17
• FRONT ASSEMBLY.....	23
• ANTIROLLBAR ASSEMBLY.....	27
• STEERING ASSEMBLY.....	28
• CENTRAL ASSEMBLY.....	31
• SHOCK ASSEMBLY.....	34
• BUMPER ASSEMBLY.....	37
• FINAL ASSEMBLY.....	40
• EXPLODED VIEWS.....	44
• TEAM SERPENT NETWORK.....	55

## LINES DESCRIPTION

Each step contains a variety of numbers, lines, and symbols. The numbers represent the order in which the parts should be assembled. The lines are described below.



Step number; the order in which you should assemble the indicated parts



Length after assembly



Assembly path of one item into another



Group of items (within lines) should be assembled first



Direction the item should be moved



Glue one item to another



Press/insert one item into another



Connect one item to another



Gap between two items

## ICONS DESCRIPTION

Each step contains a variety of symbols described below.



Carefull, read and check very well.



Apply a small amount of cyano glue. Use wear protection for eyes and hands.



Detail view to explain assembly or order of parts better.



Default set-up: This symbol indicates the default setup.



Grease: apply a small amount of grease to the parts shown.



Left and right parts should be assembled in the same way.



Thread lock: apply a small amount on the parts shown. Before to apply the threadlock, make sure to degrease the parts very well, as otherwise the threadlock will not work.



Silicone oil: use the indicated silicone oil for the shocks and differentials.



Parts or items not included in the kit.



Optional part, not standard in the kit.

## STEP 1

## DIFF BAG

### 1.1

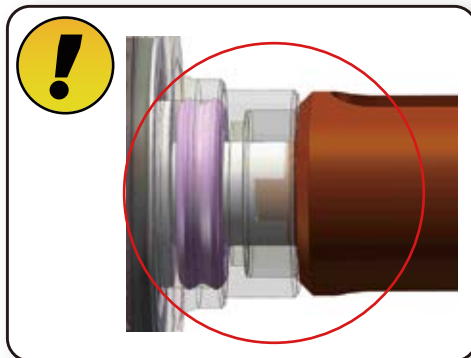
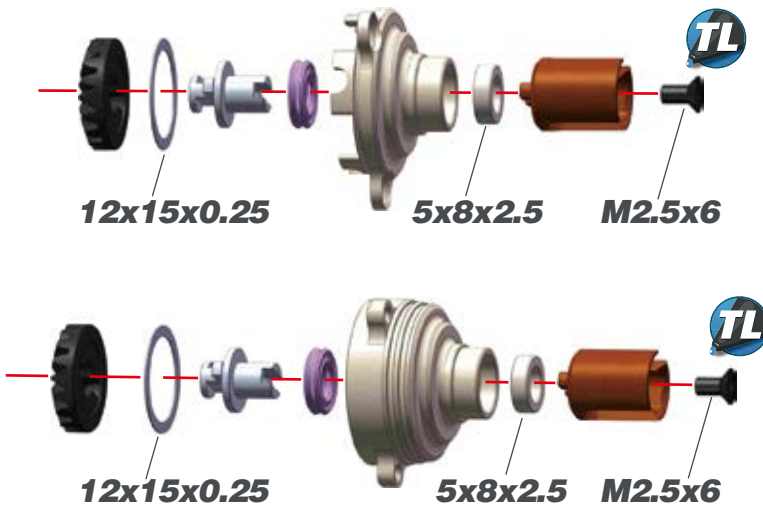

### 1.2



### AMOUNT OF OIL IN THE DIFFS

Use a digital scale to measure the exact amount of oil in the diff.

Differential weight with volume compensators = 8.4 grams



### 1.3

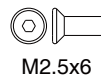
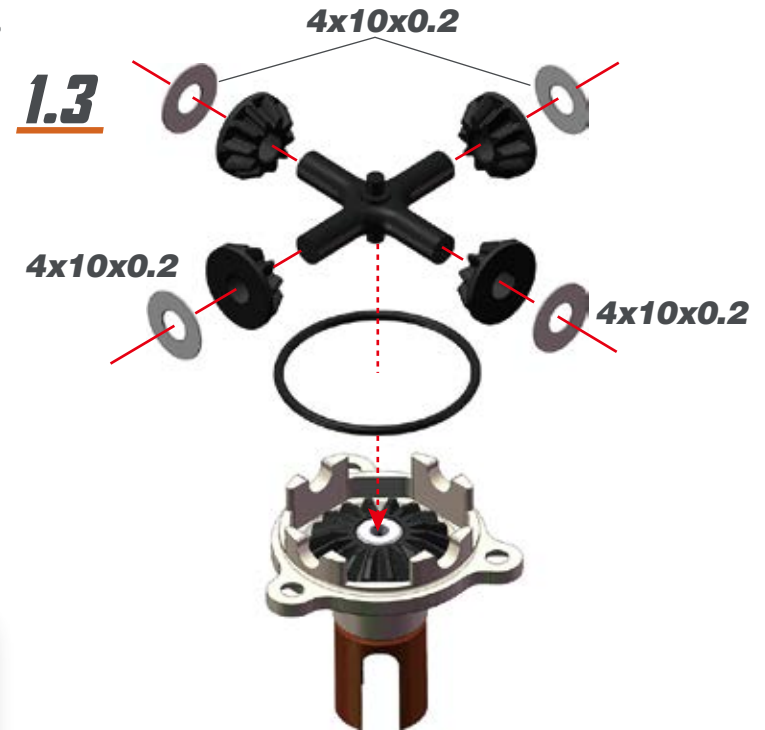

## STEP 1

## STEP 2 SOLID AXLE BAG

1.4

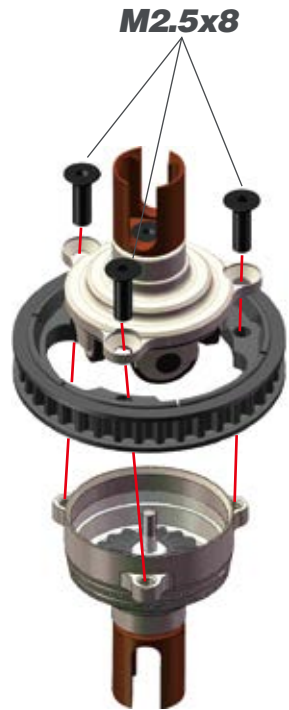

M2.5x8

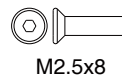
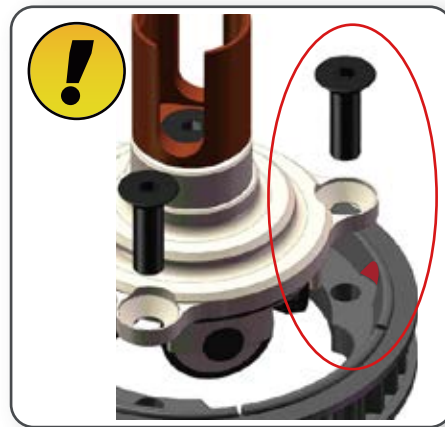

M2.5x8

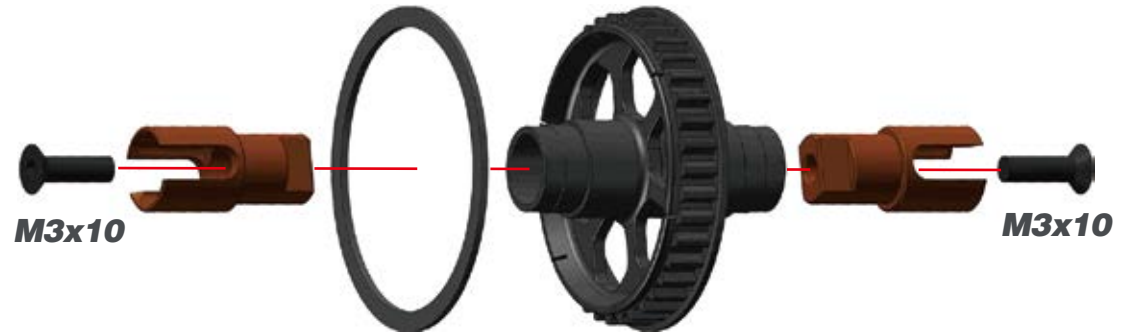

M3x10

M3x10

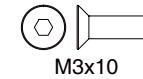

M3x10

## STEP 3 DJC BAG

### 3.1

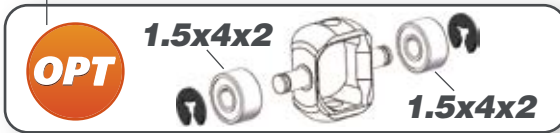
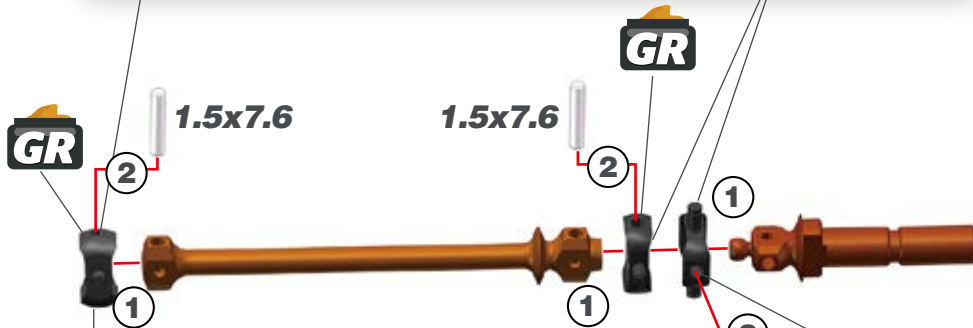
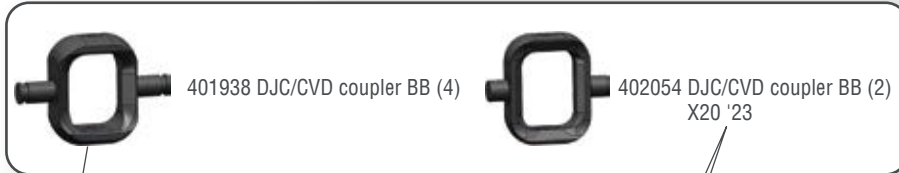

1.5x8

### 3.2

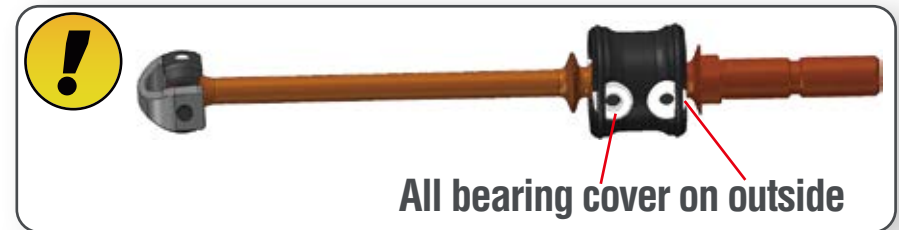
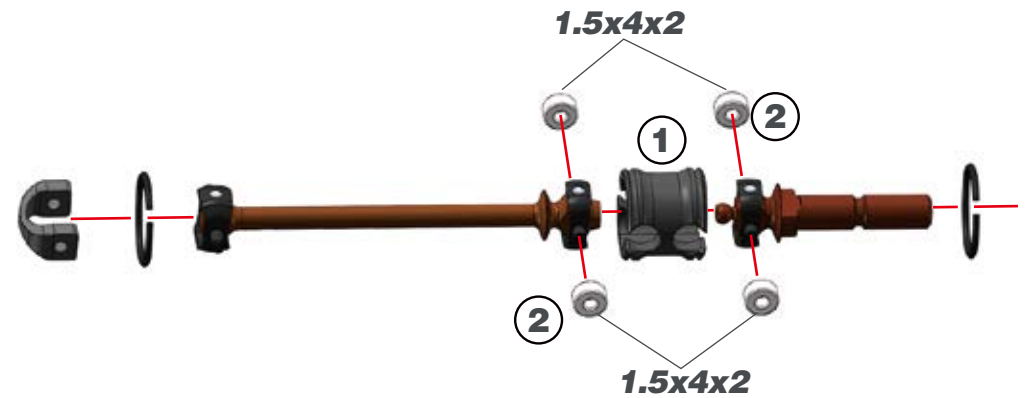
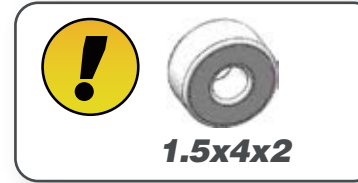

1.5x4x2

## STEP 4 CVD BAG

### 4.1

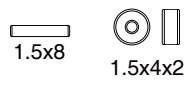
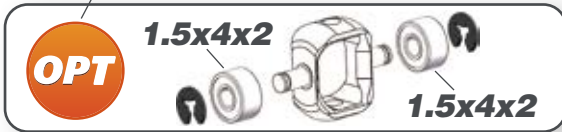
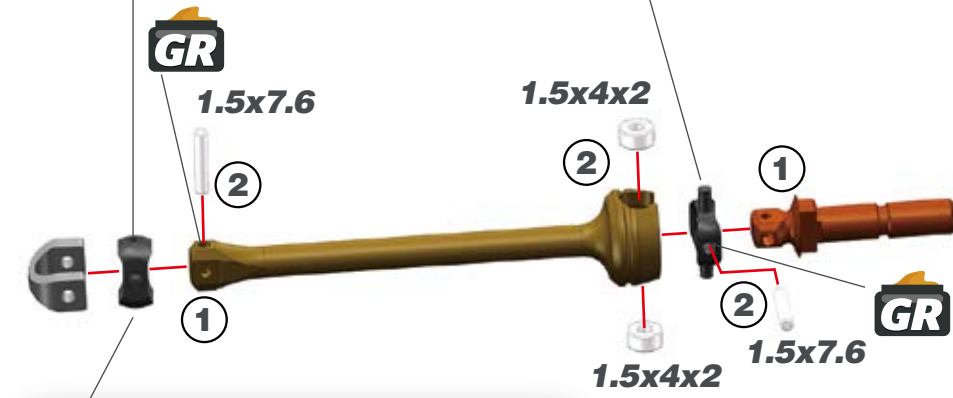

### 4.2



OPT

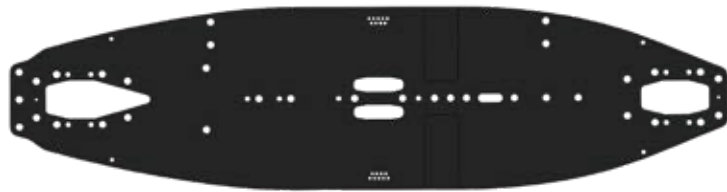

402191 Chassis alu X26

OPT

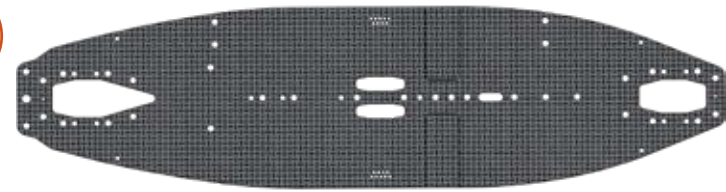

402192 Chassis carbon X26

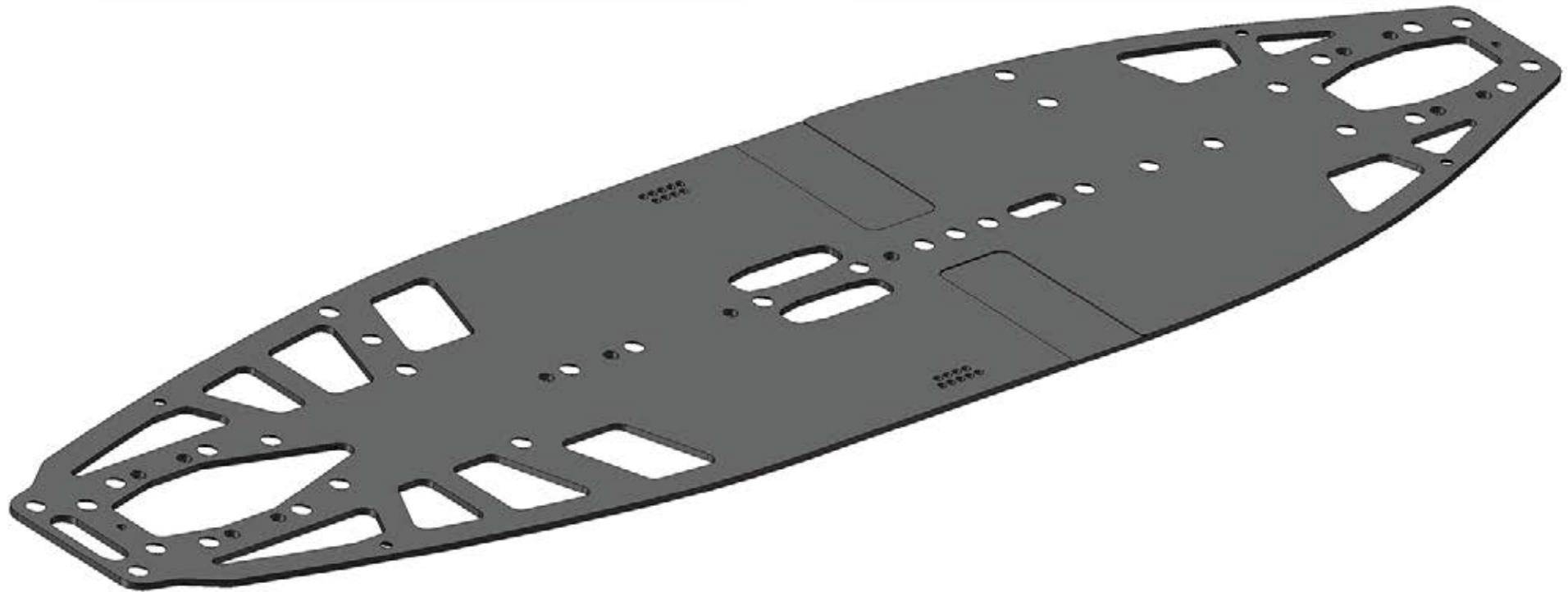

## STEP 5

## BAG 1

### 5.1 FRONT/REAR

4X



### 5.2 REAR

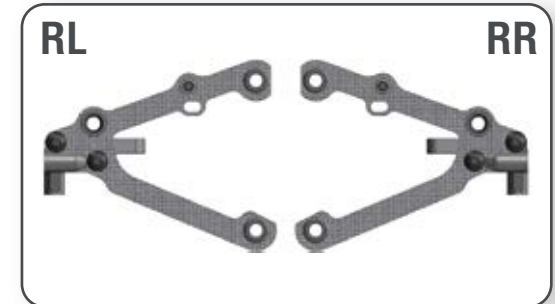
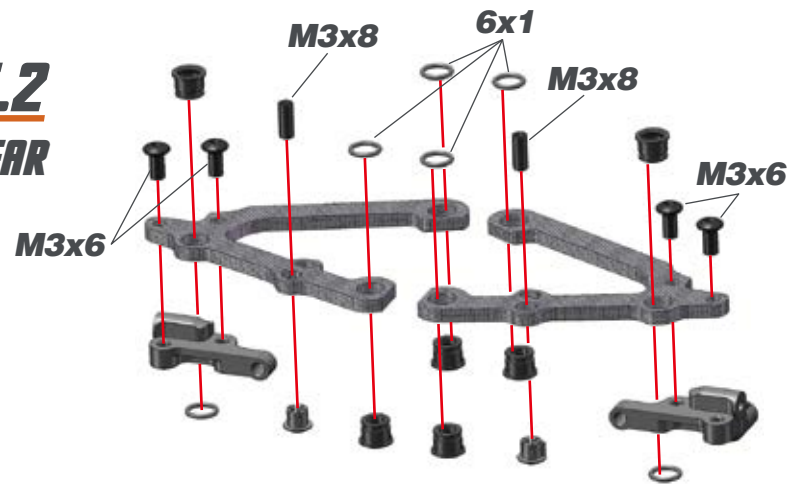

### 5.3 FRONT

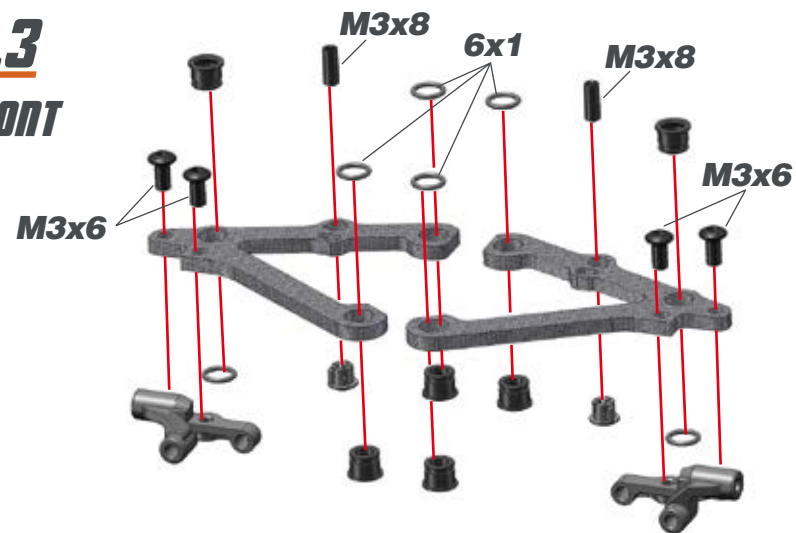

## STEP 6

### 6.1 FRONT

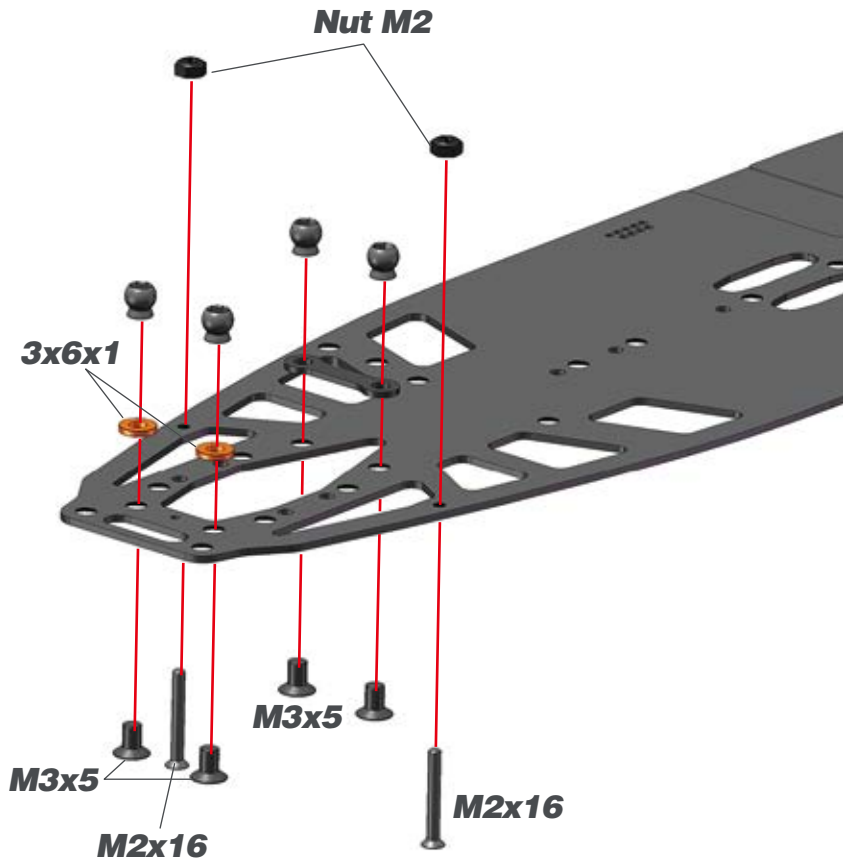

### 6.2

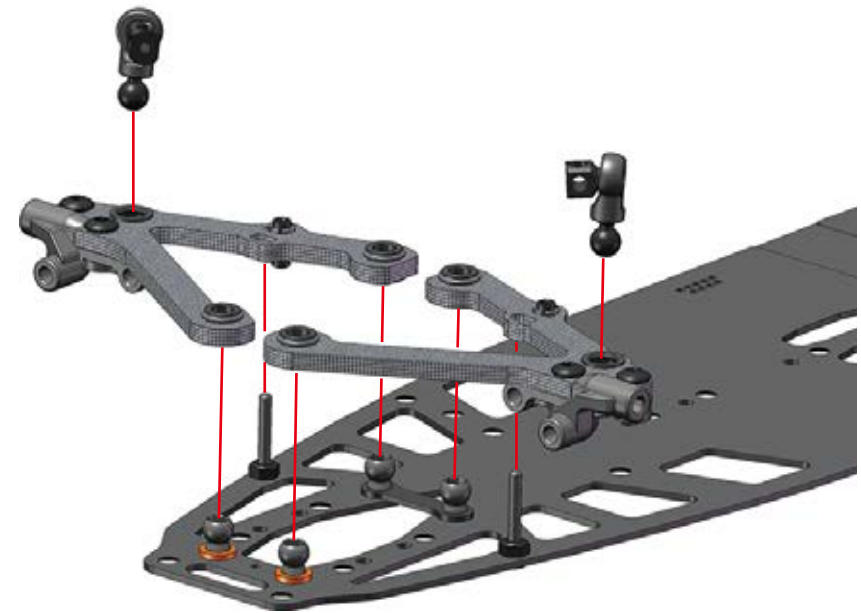

Nut M2



M3x5



3x6x1

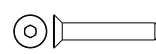

M2x16

## STEP 6

### 6.3 REAR

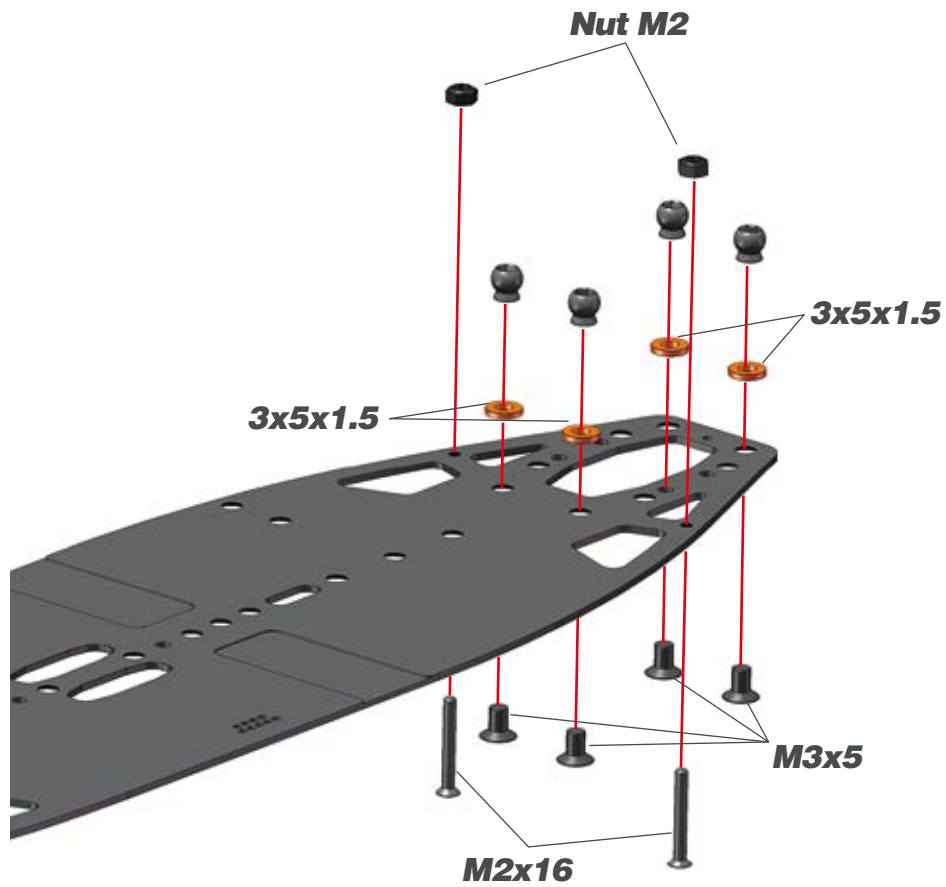

### 6.4

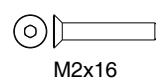
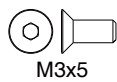
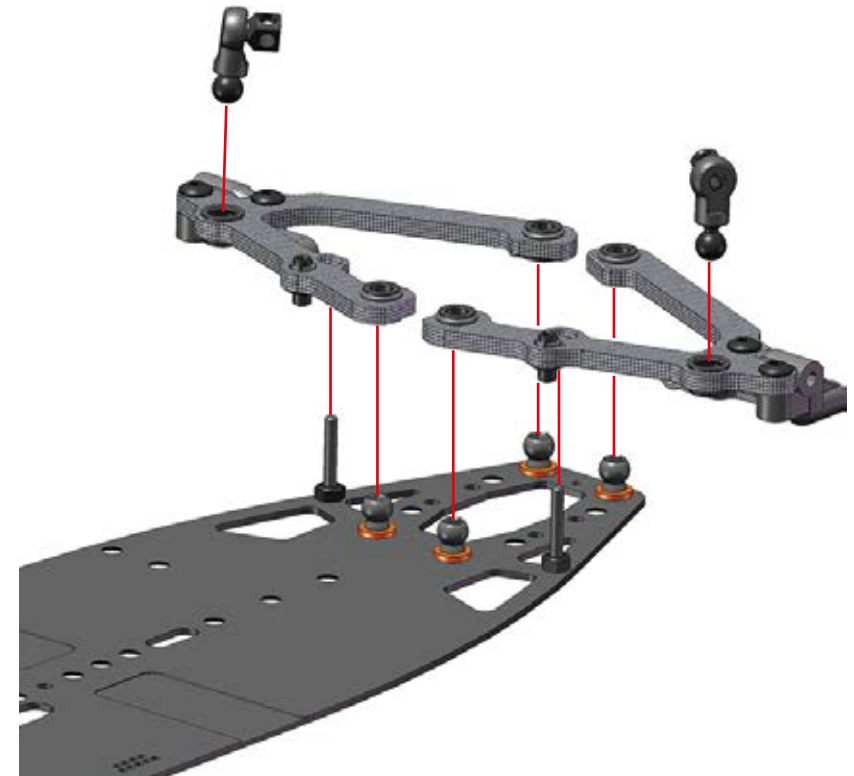

## STEP 6

### 6.5

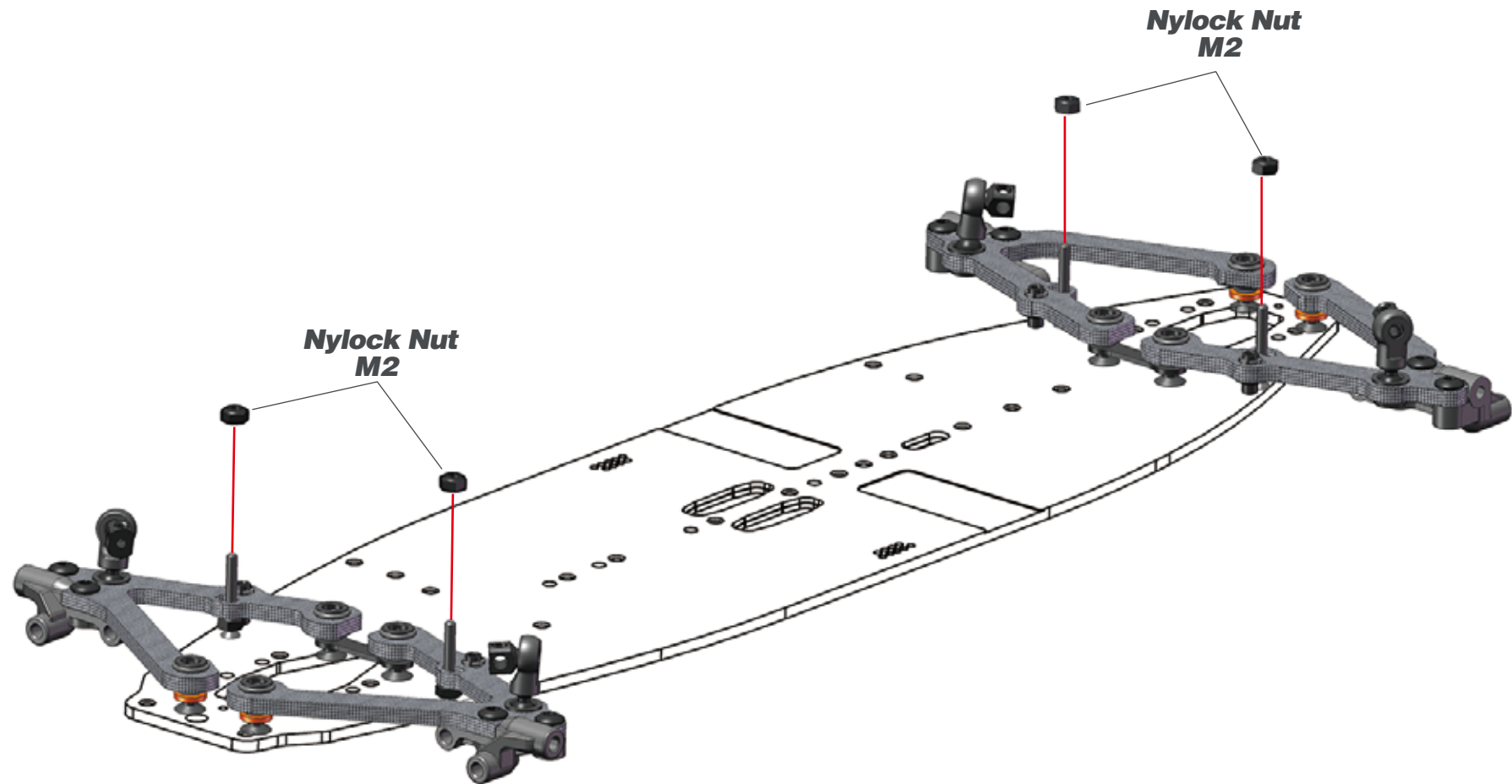

Nylock Nut M2

## STEP 7

## BAG 2

### 7.1 FRONT

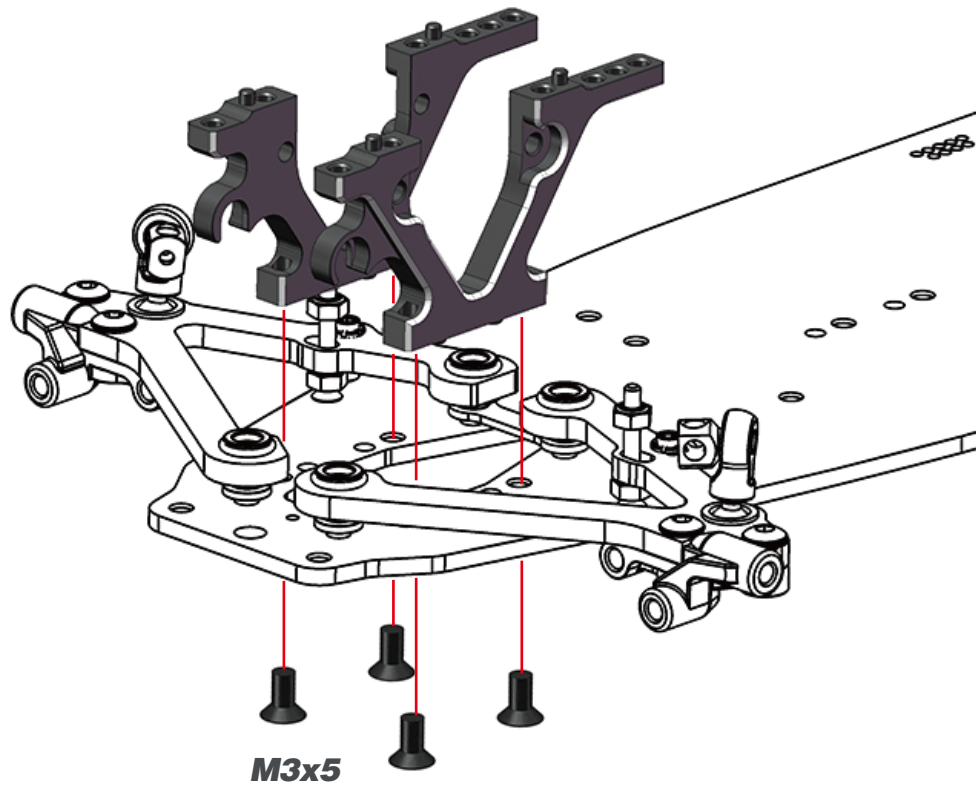

### 7.2 REAR

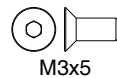
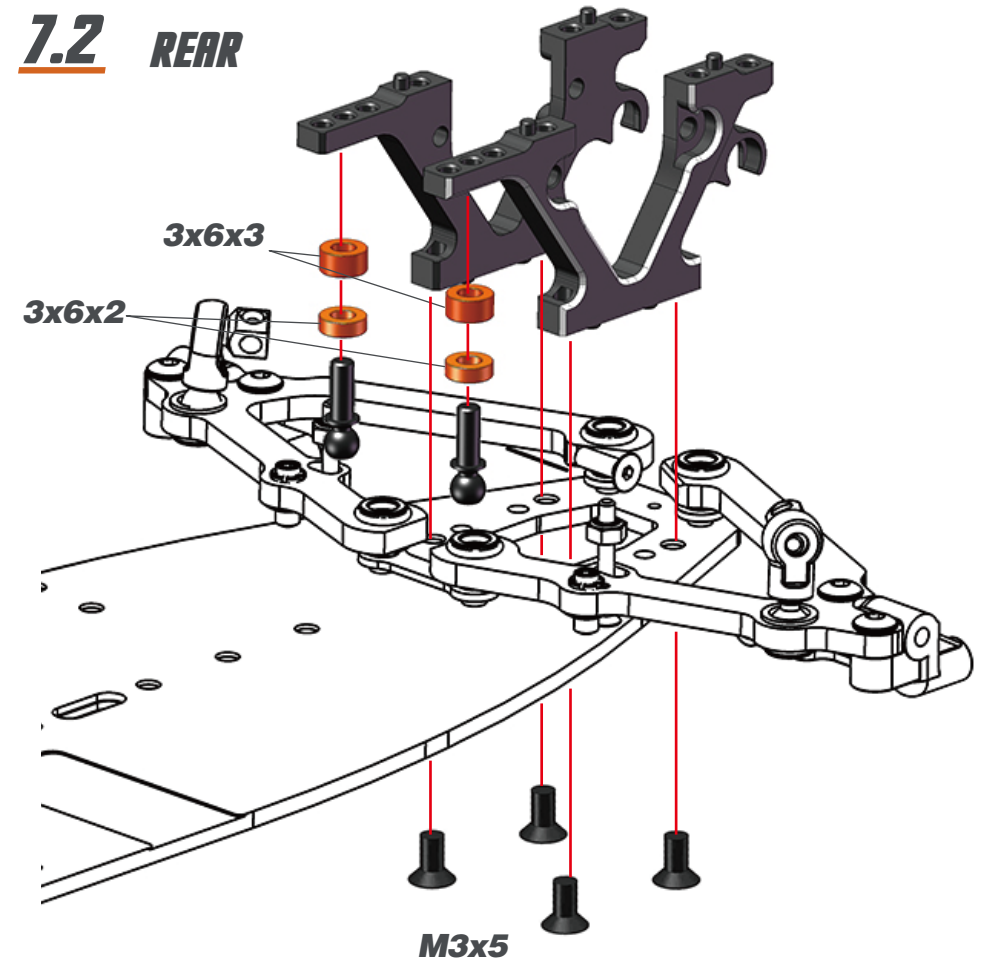

M3x5



3x6x2



3x6x3



PIVOTBALL M3x7



M3x5

## STEP 8

### 8.1

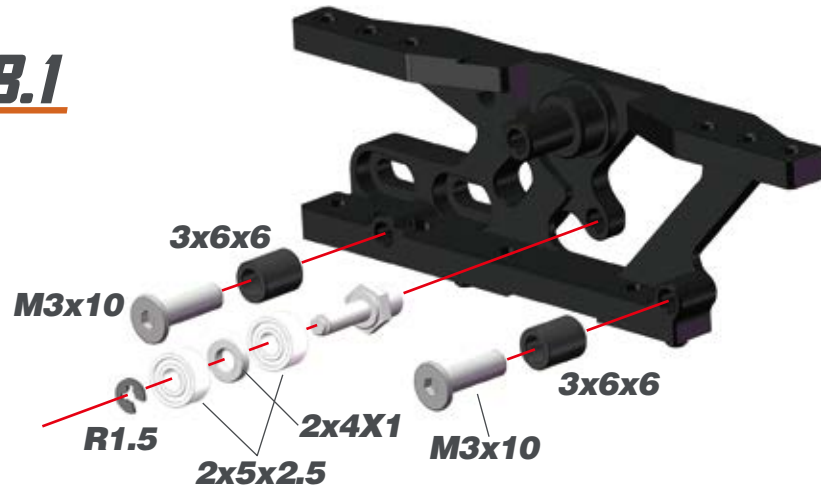

### 8.2

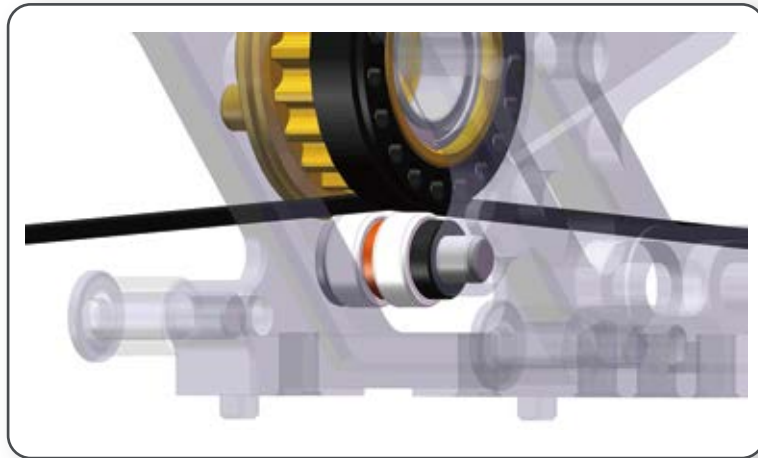
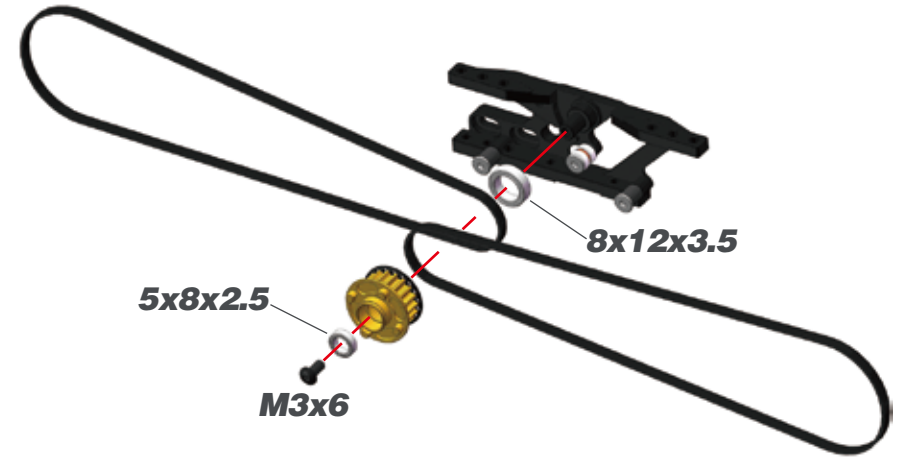

### 8.3

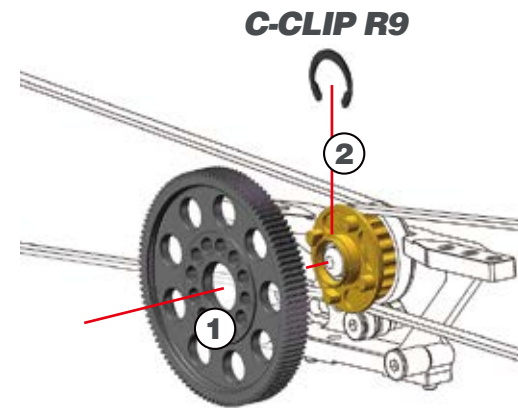



**10g**



**OPT**

402067 Motormount weight 10gr X20 '23



**5g**

402066 Motormount weight 5gr X20 '23

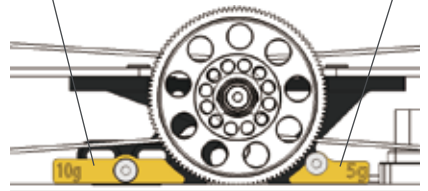



## STEP 9

### 9.1

OPT



401917 Bearing excenter fr/rr (4) alu X20

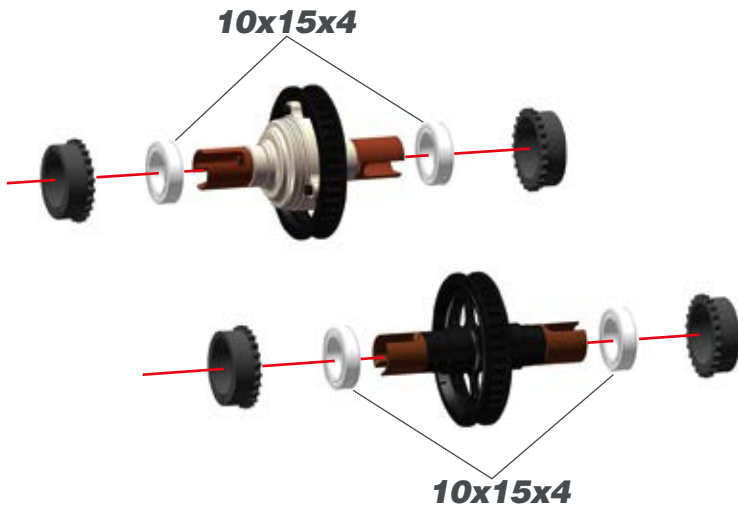

### 9.2

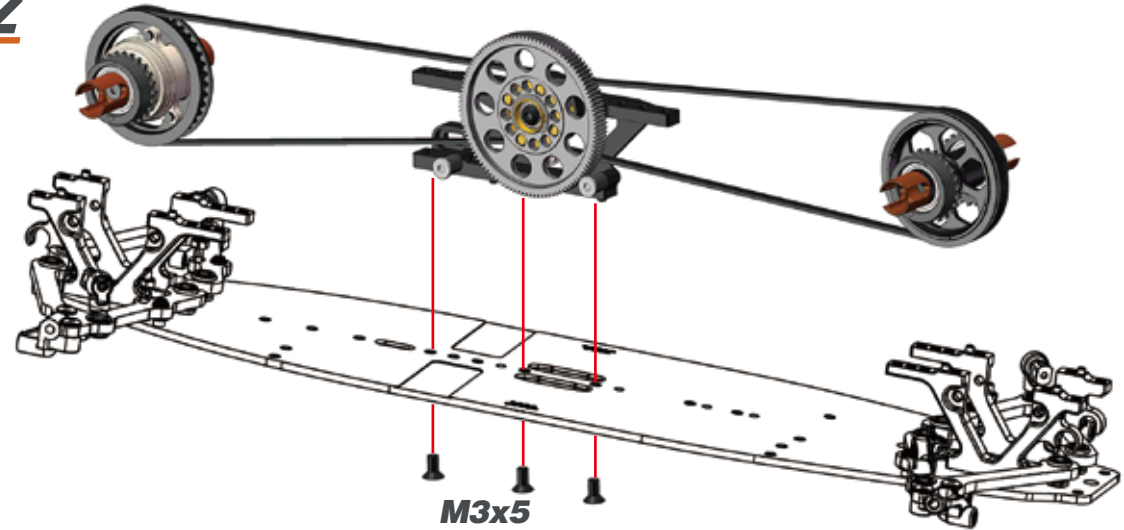

M3x5

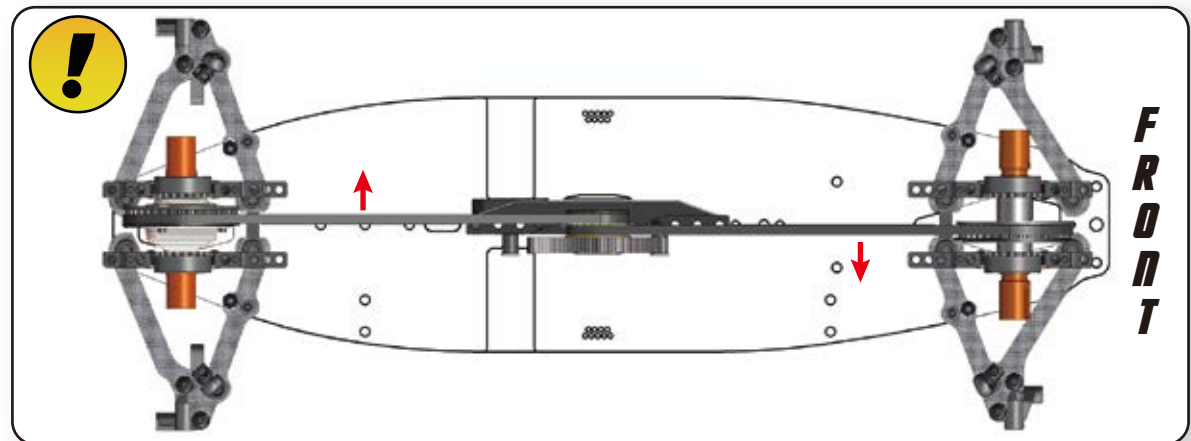

10x15x4



M3x5

## STEP 9

9.3

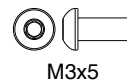
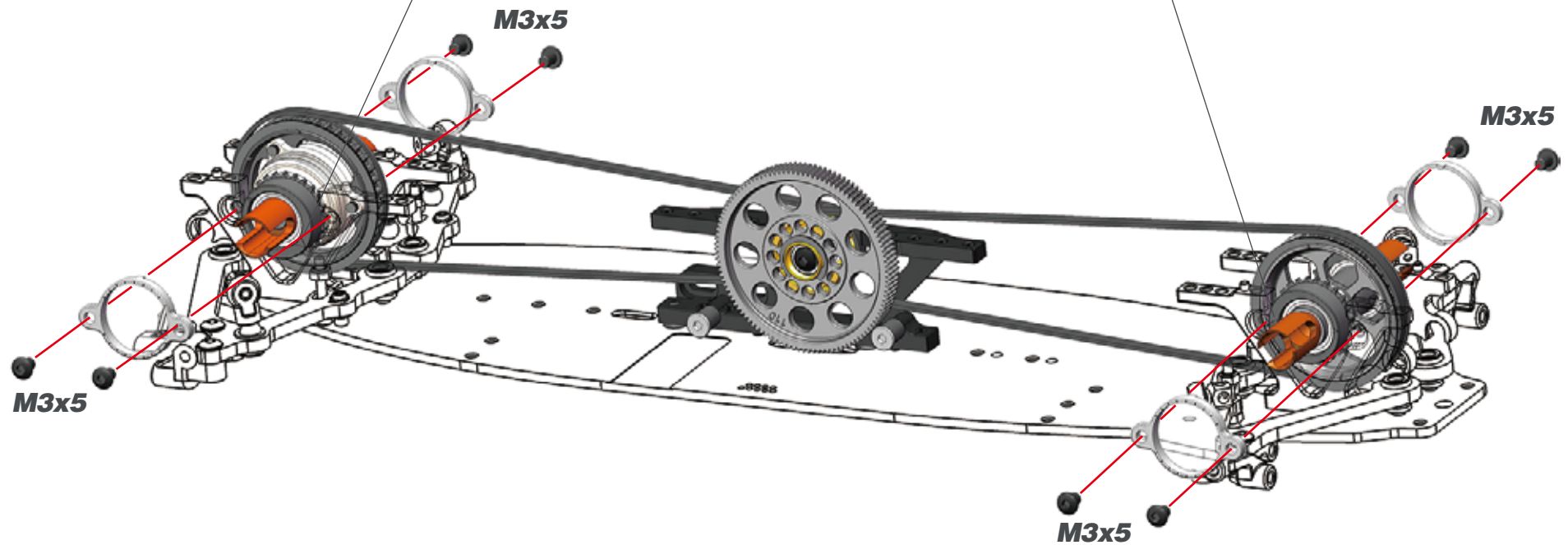
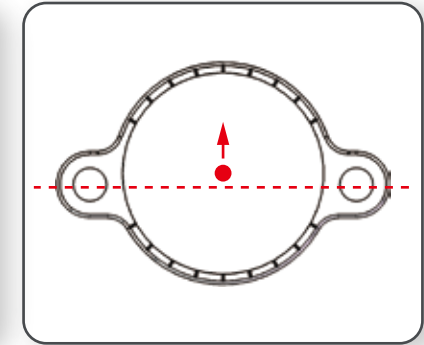
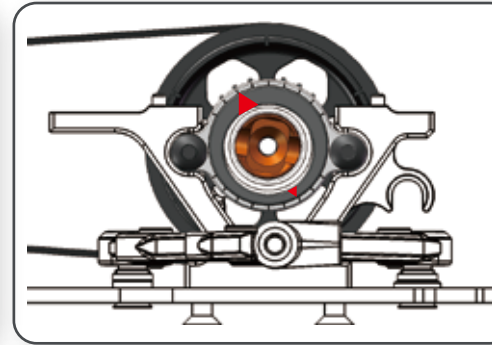
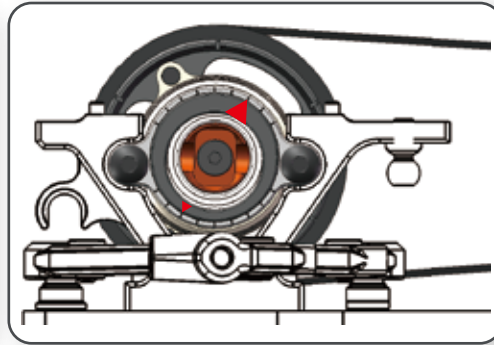
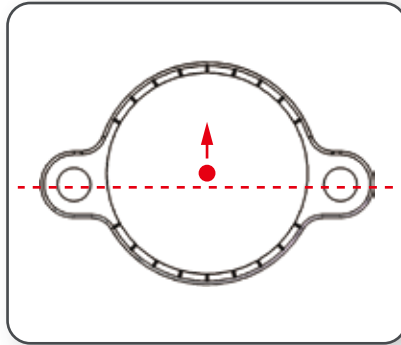

## STEP 10 BAG 3

### 10.1



### 10.2



2X



○   
2x12

## STEP 10

### 10.3 REAR

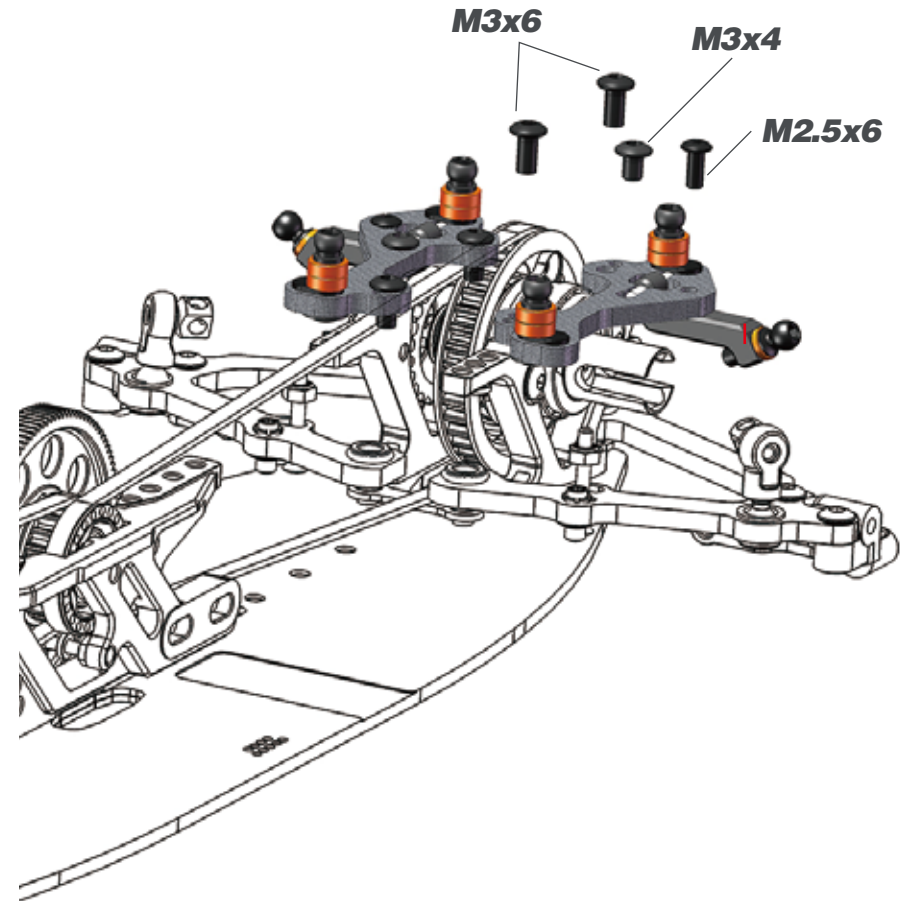
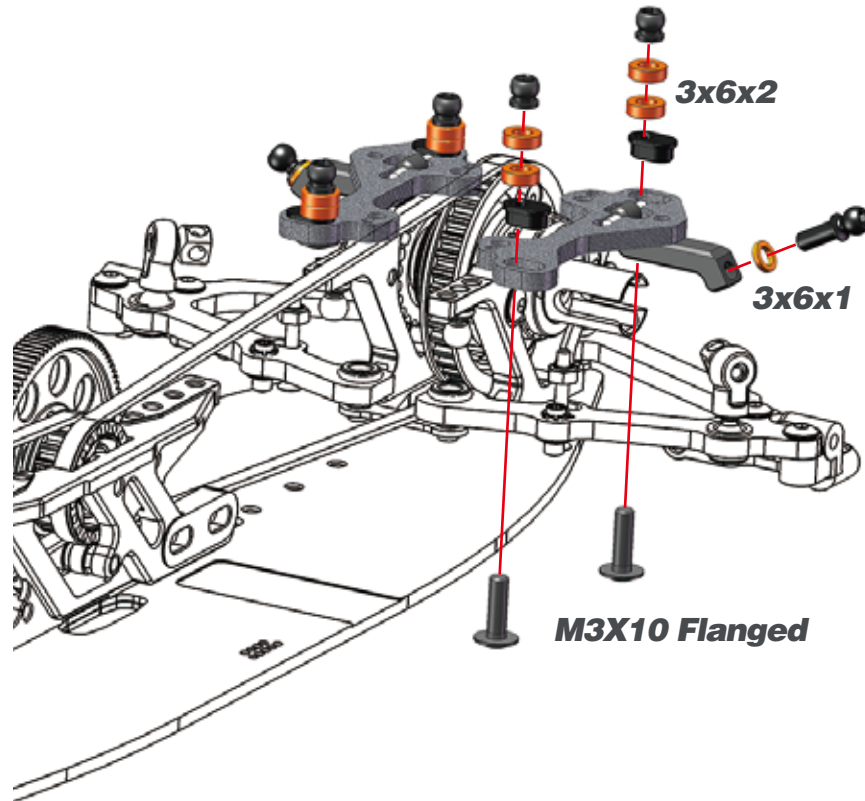

3x6x1



3x6x2



M3x10 Flanged



PIVOTBALL M3x7



M3x6



M3x4



M2.5x6

## STEP 11

### 11.1

2X

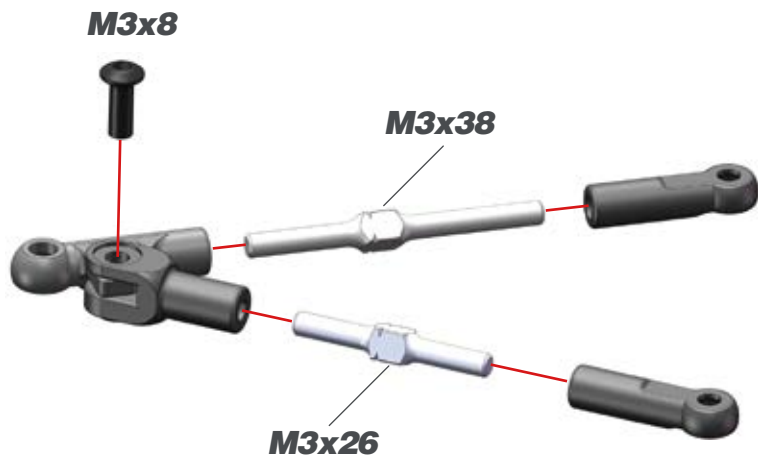

### 11.2

2X

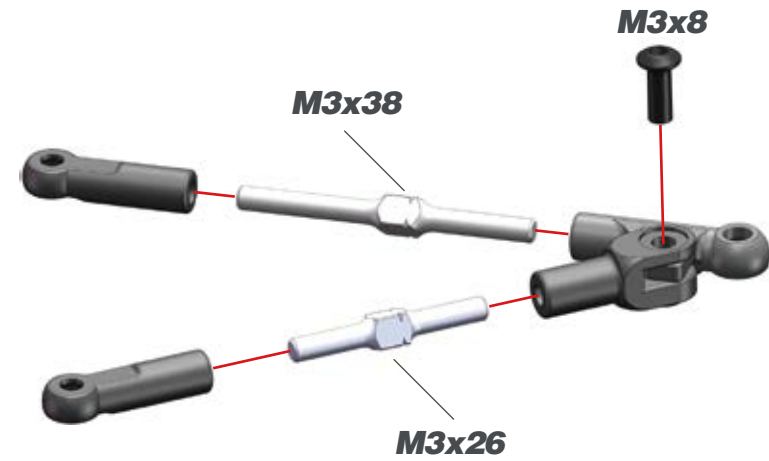

## STEP 11

**FRONT LEFT  
UPPER ARM**

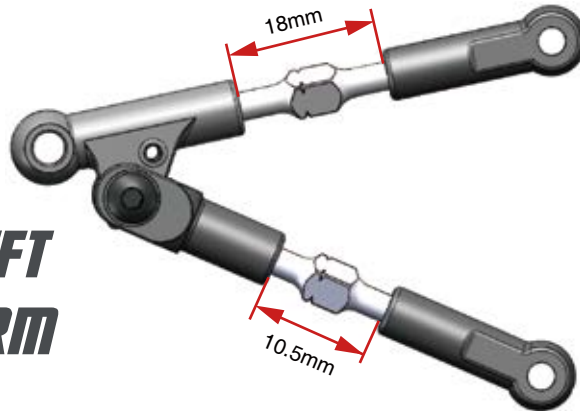

**FRONT RIGHT  
UPPER ARM**

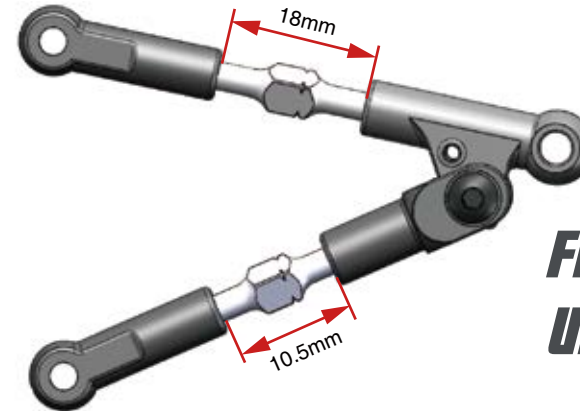

**REAR LEFT  
UPPER ARM**

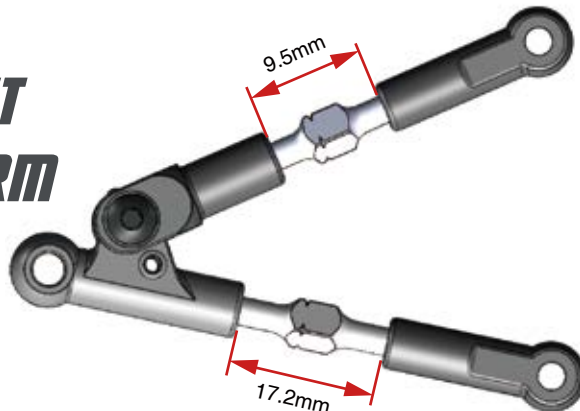

**REAR RIGHT  
UPPER ARM**

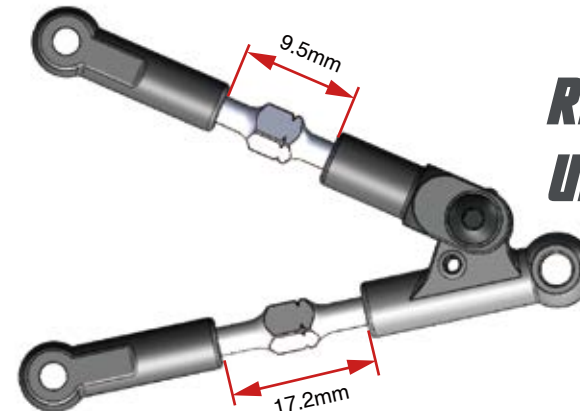

**Notes:** This basic setup is 2 degree camber for front and rear, 4 degree caster for front and -4 for rear.

## STEP 12

R=L

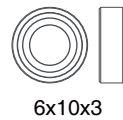
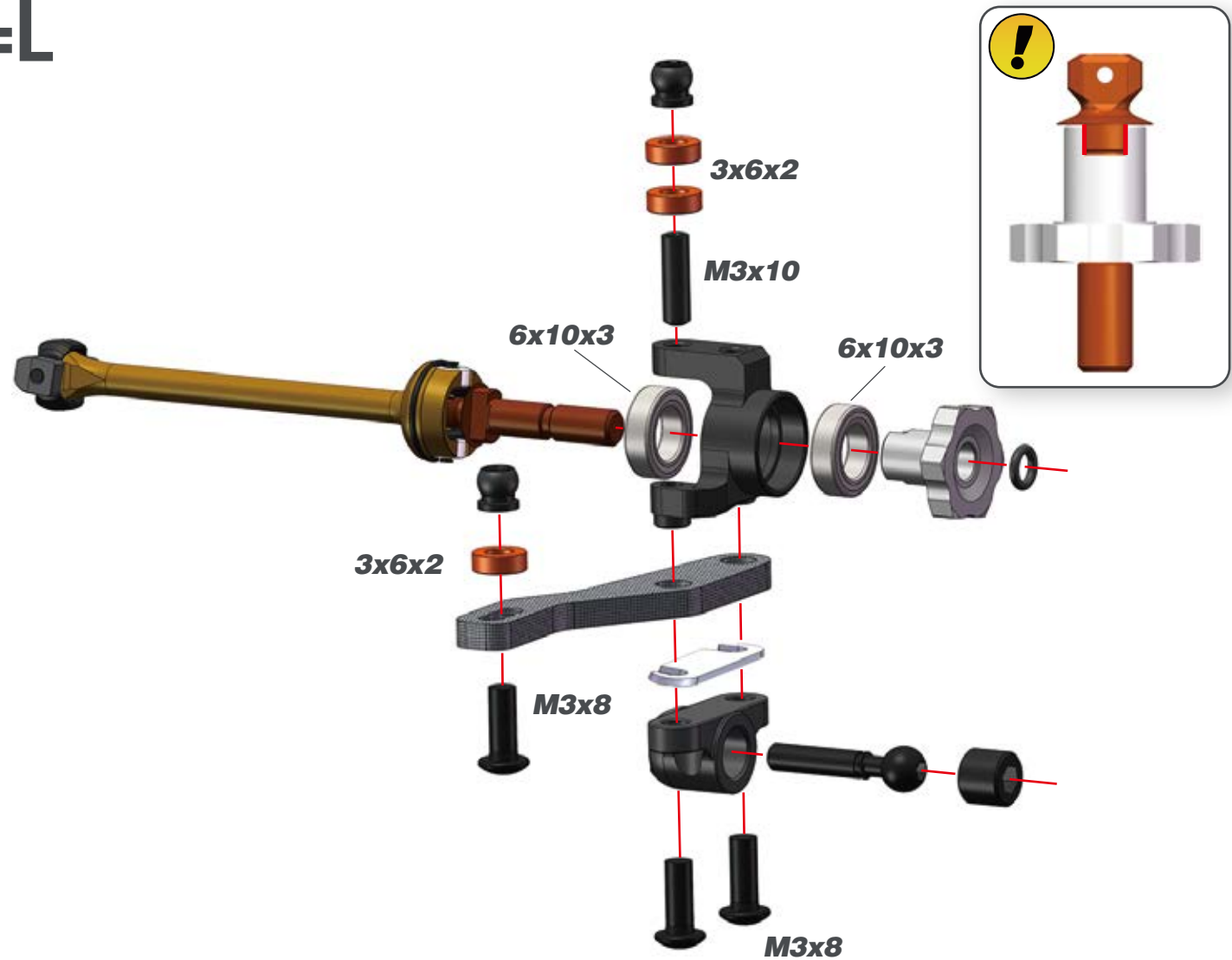

## STEP 13

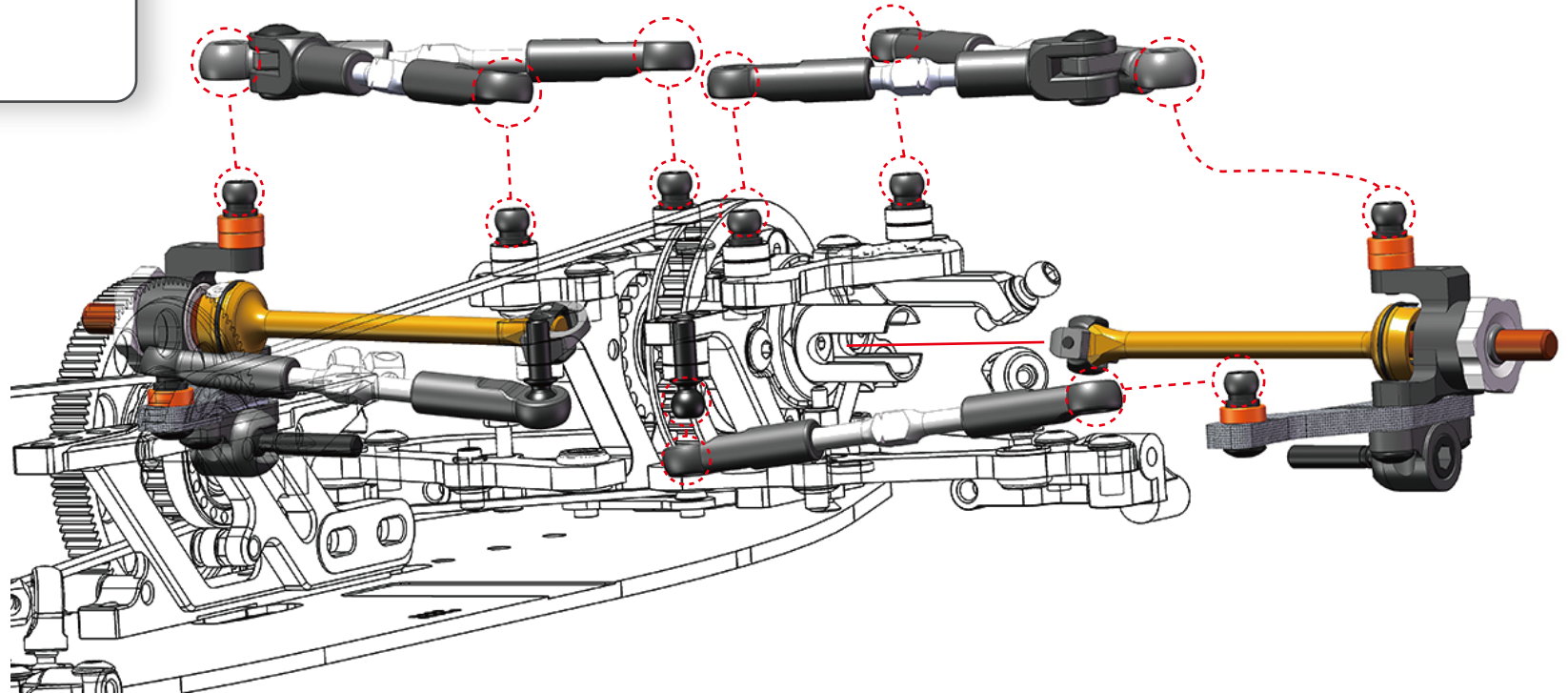
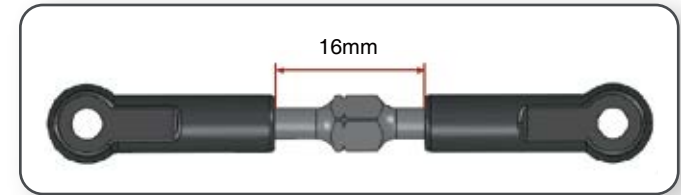
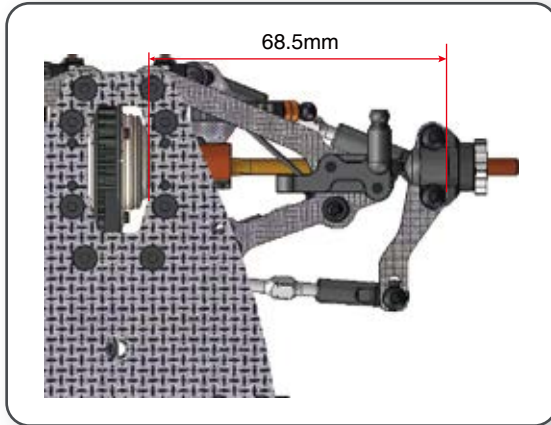

## STEP 14 BAG 4

### 14.1

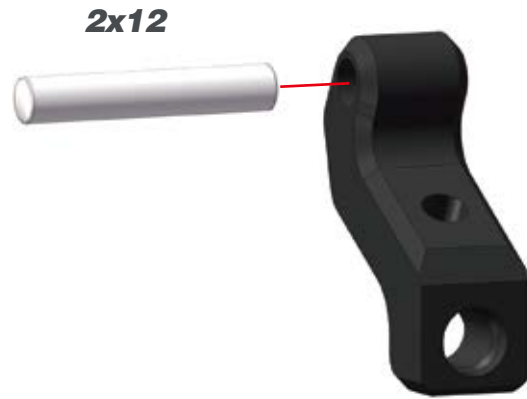

### 14.2



2X



○   
2x12

## STEP 14

### 14.3 FRONT

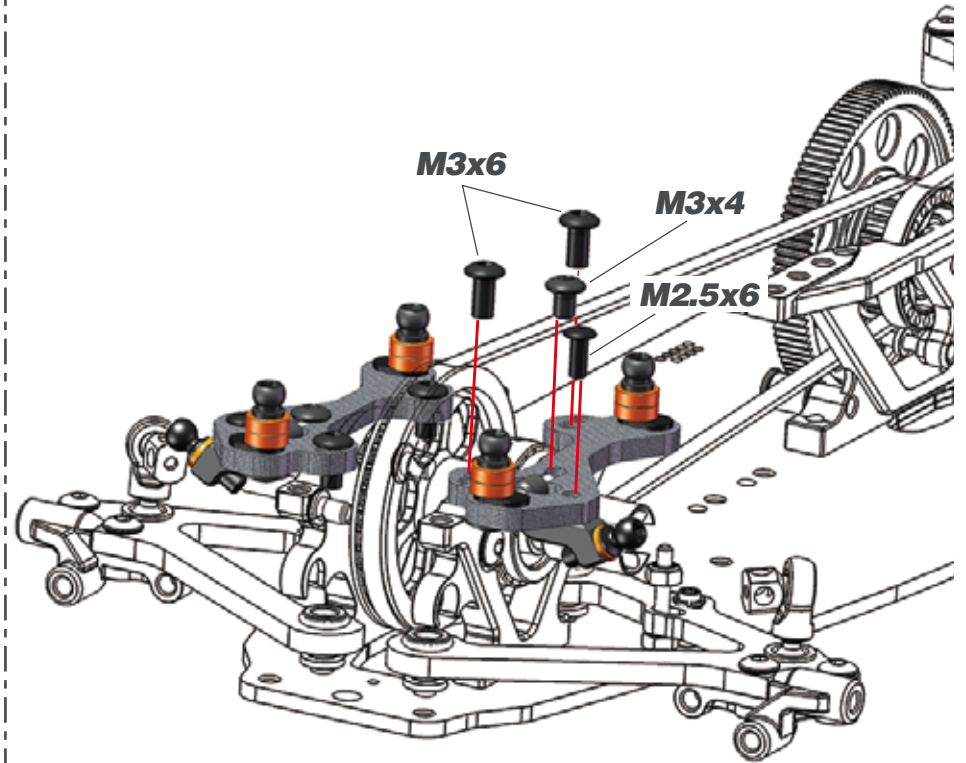
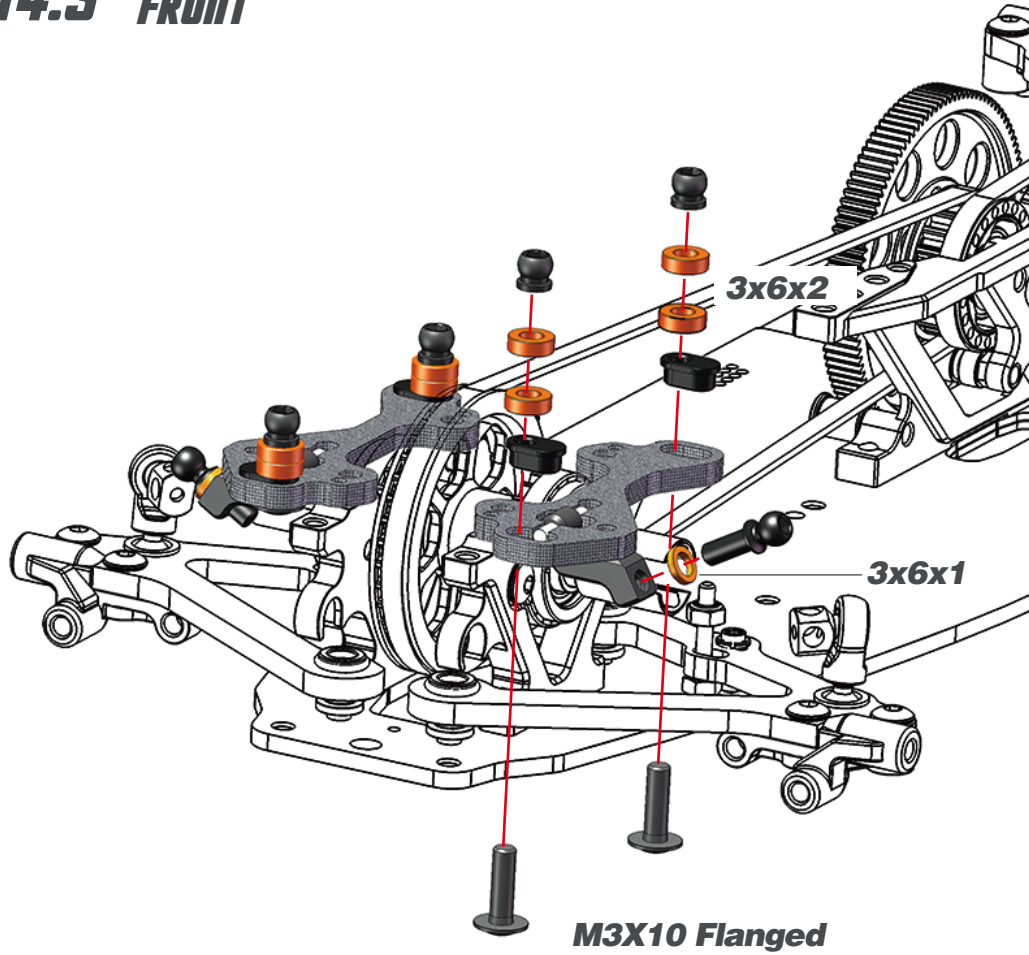

## STEP 15

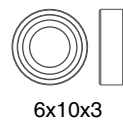
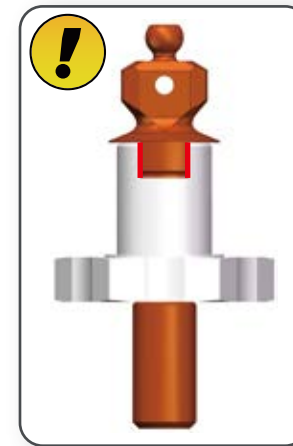
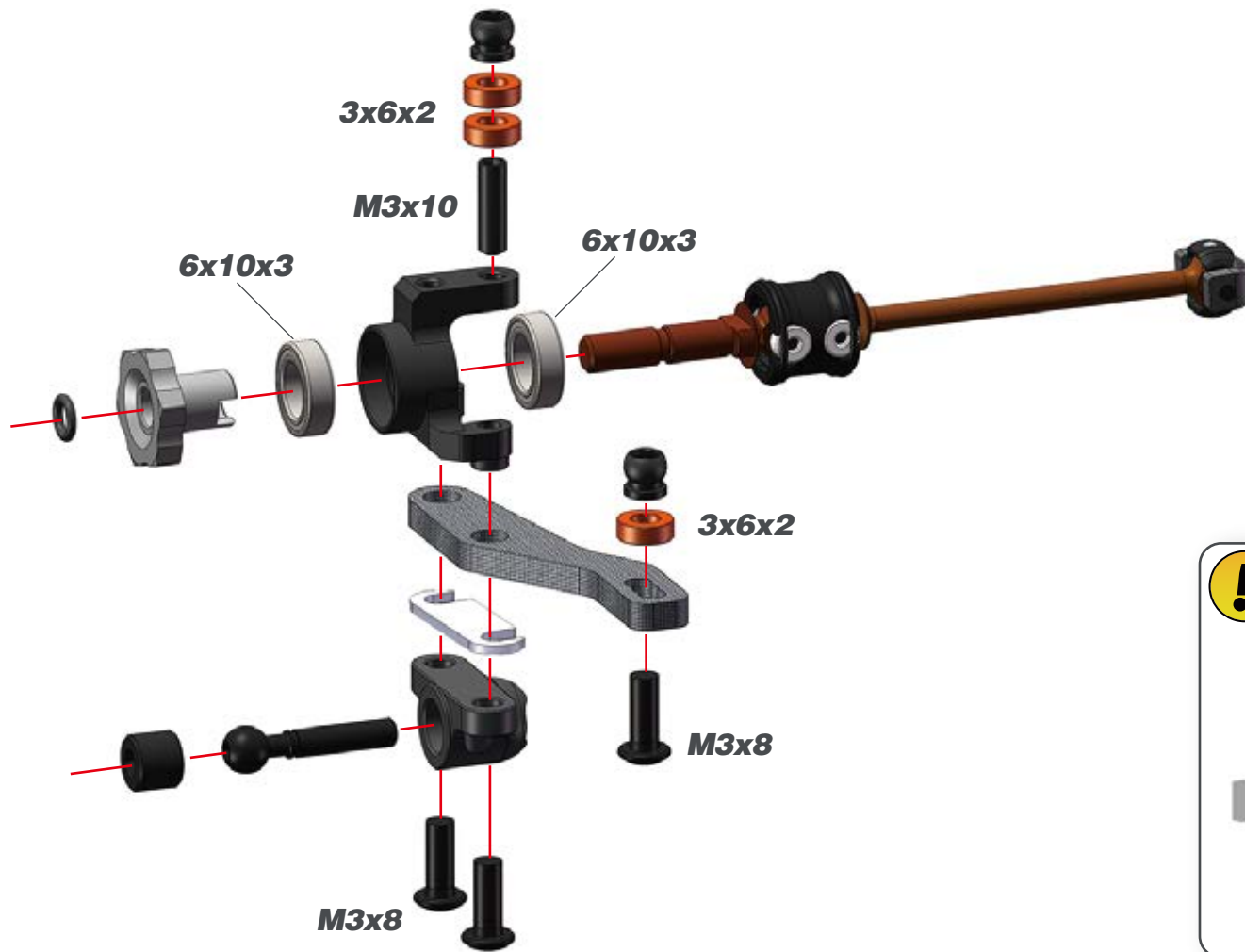

## STEP 16

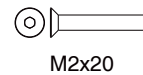
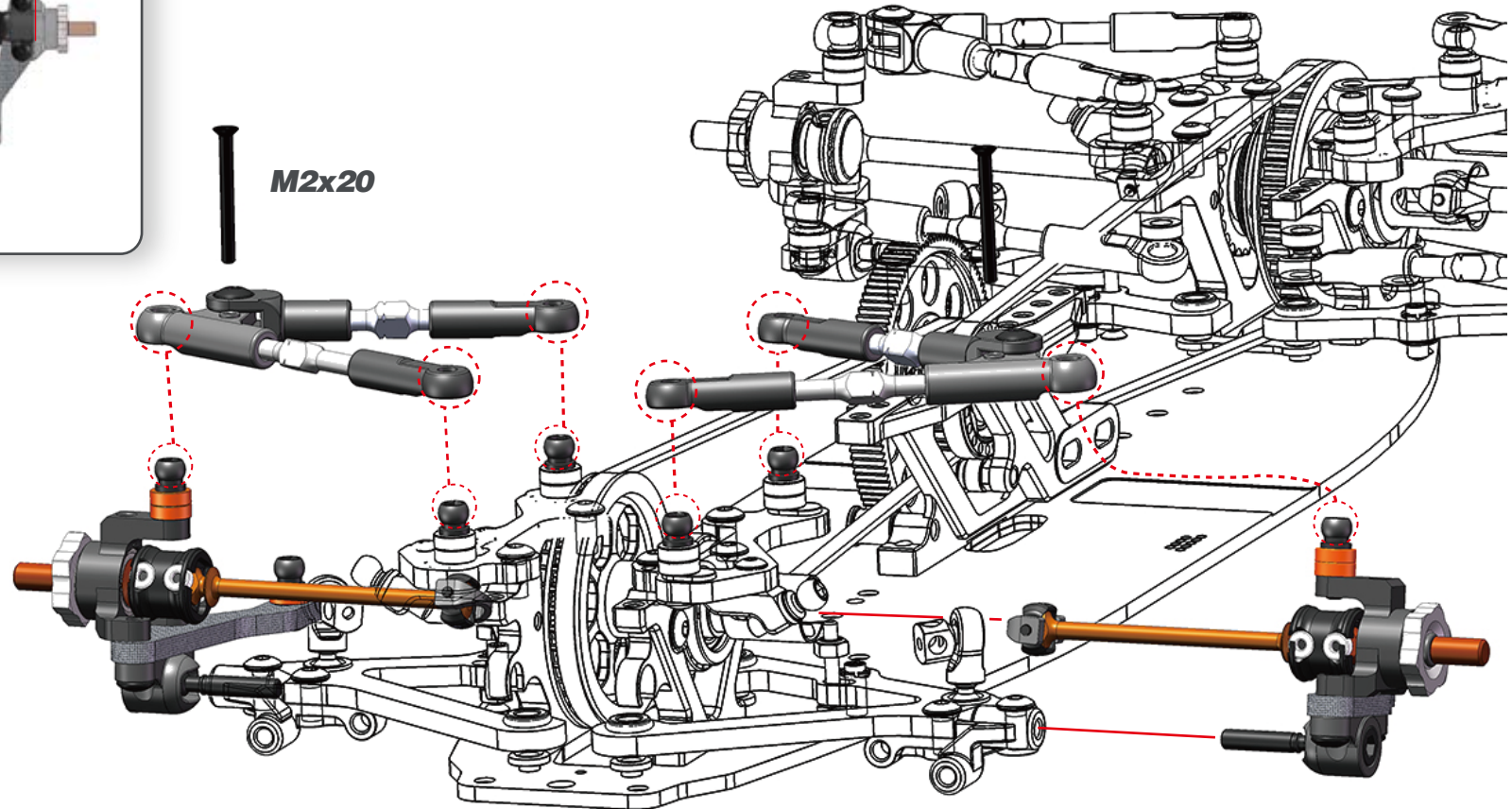
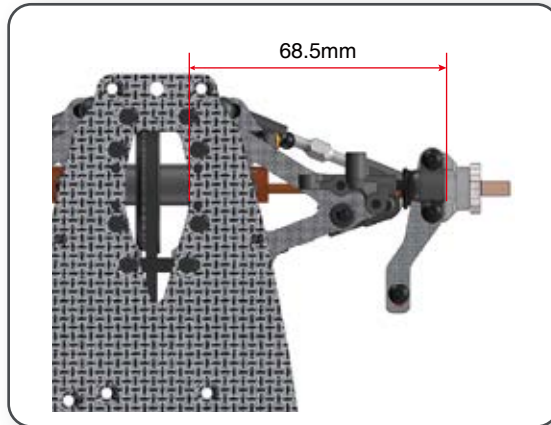

## STEP 17 BAG 5

### 17.1 FRONT & REAR

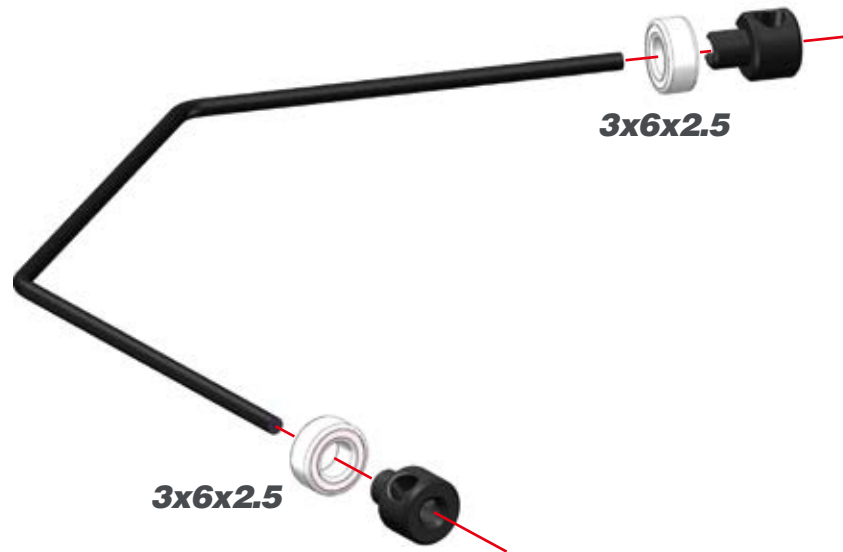

### 17.2 REAR

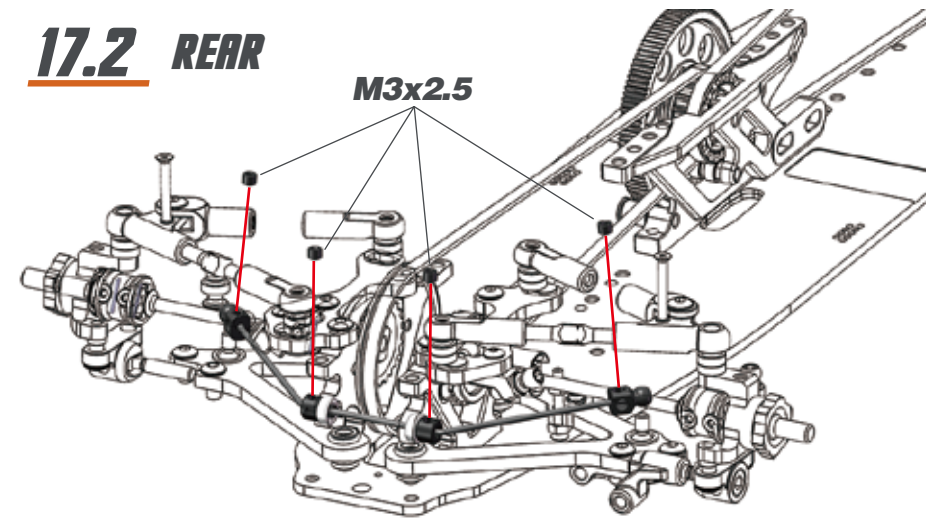

### 17.3 FRONT

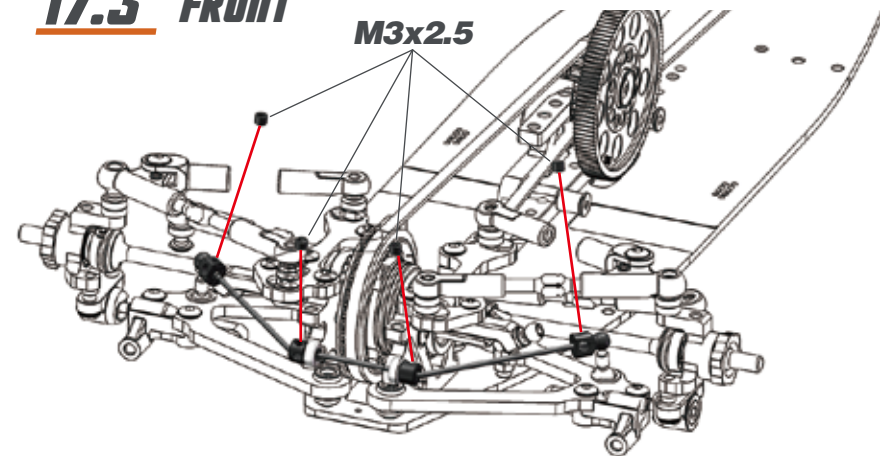

## STEP 18

### 18.1

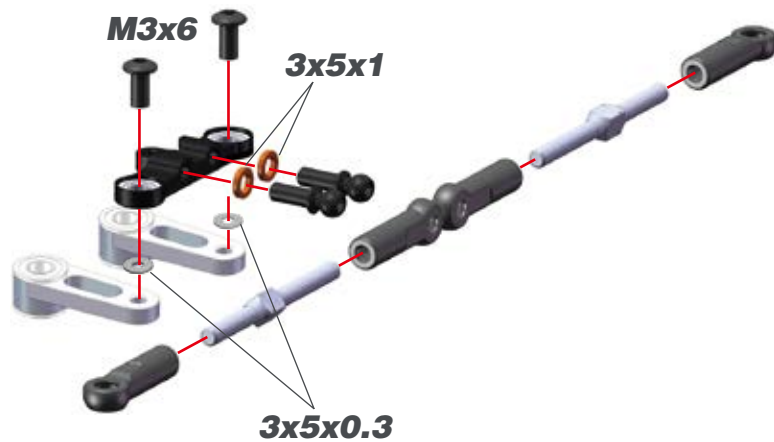
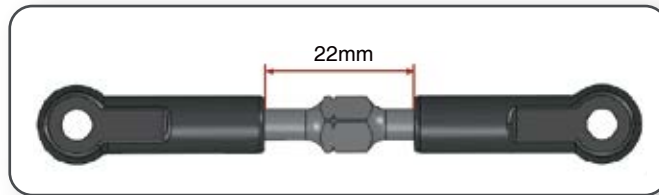

### 18.2

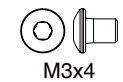
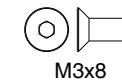
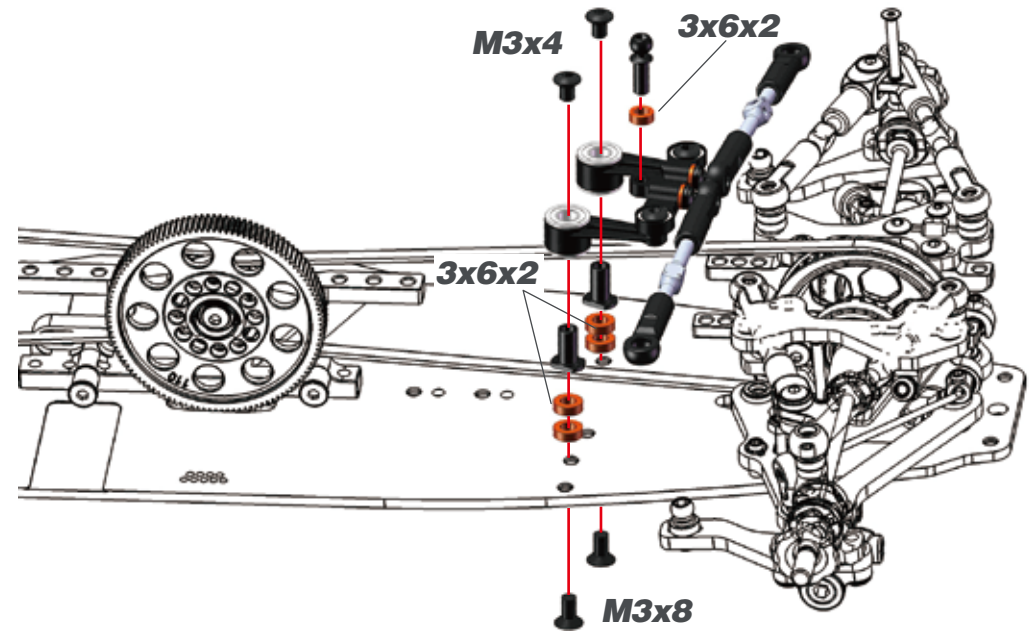

## STEP 19

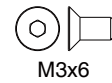
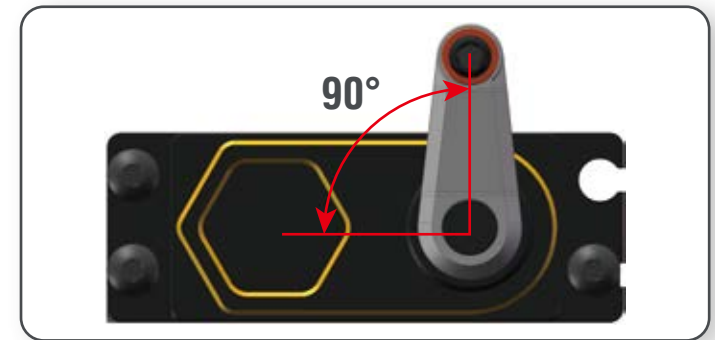

## STEP 20

### 20.1

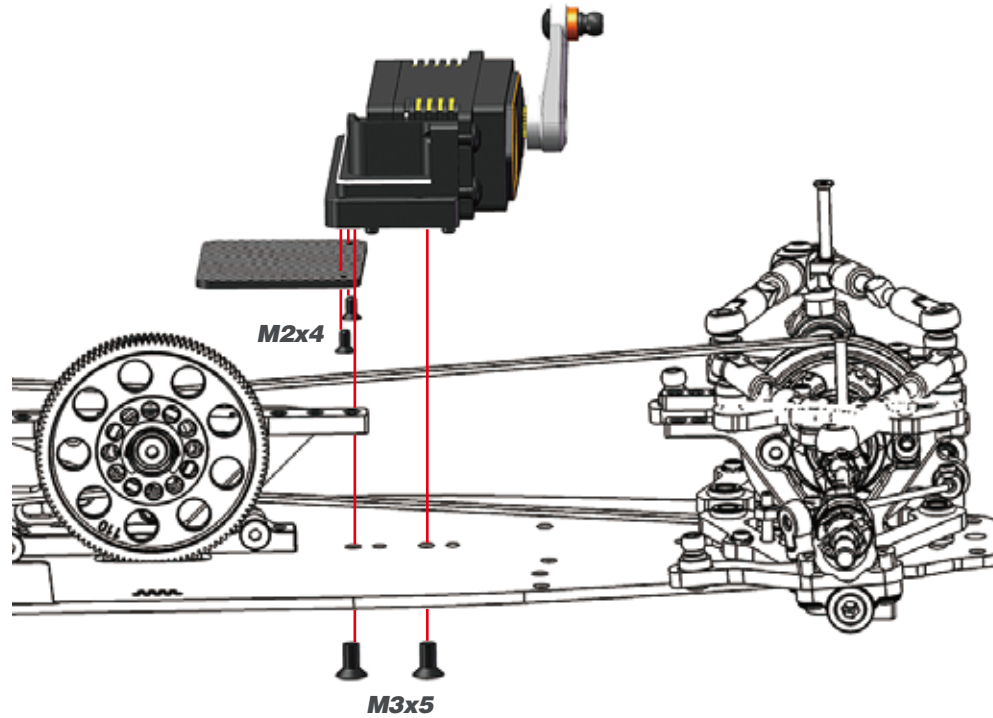

### 20.2

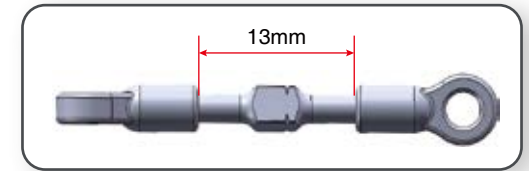

### 20.3

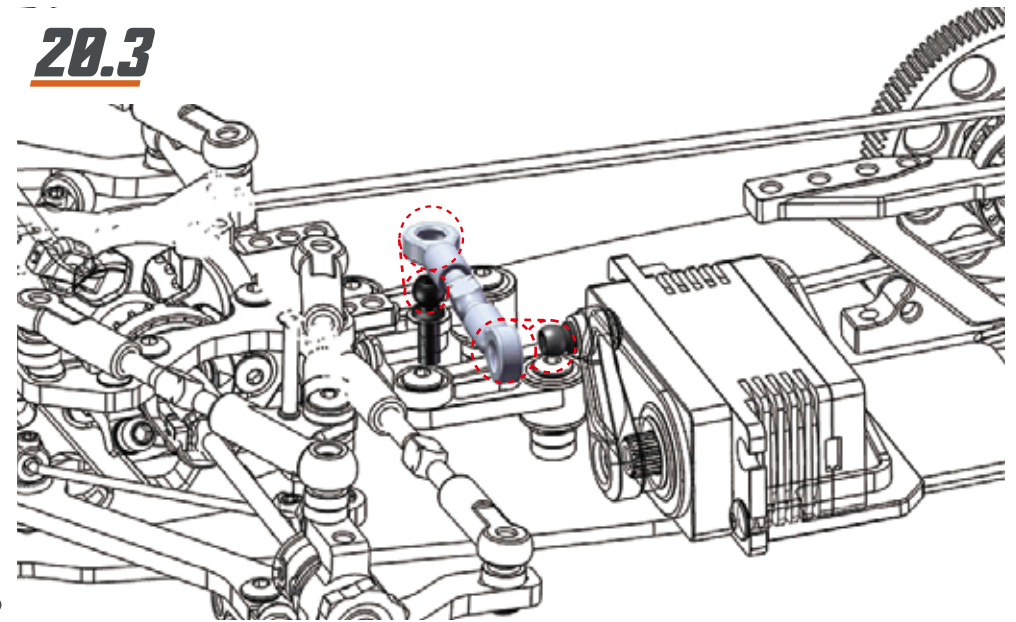

## STEP 21 BAG 6

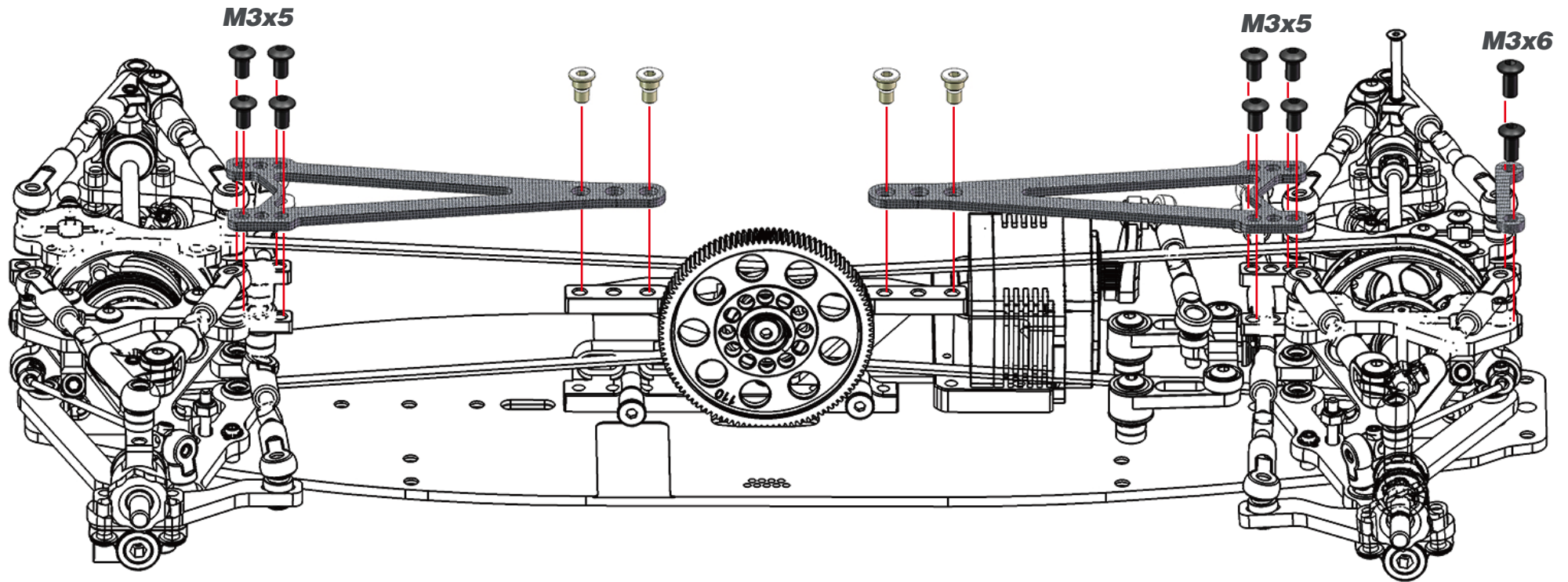

## STEP 22

R=L

M3x16 Flanged

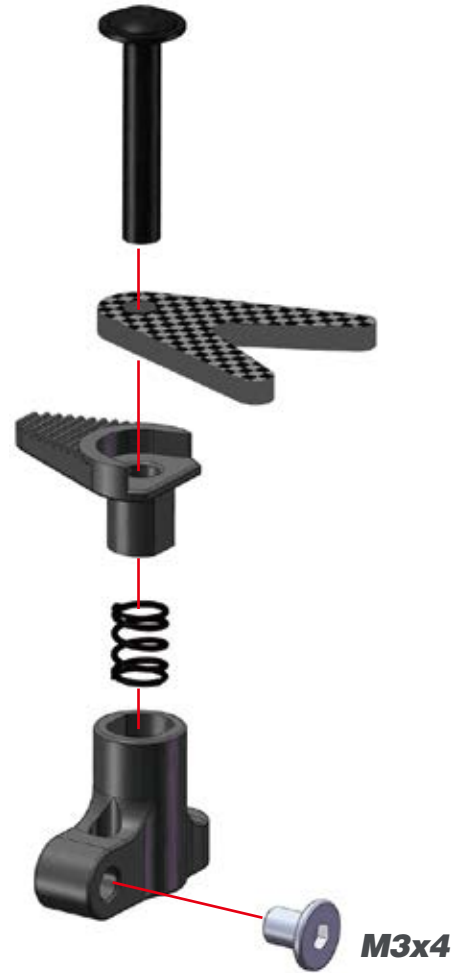

M3x4

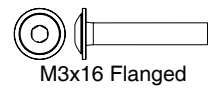
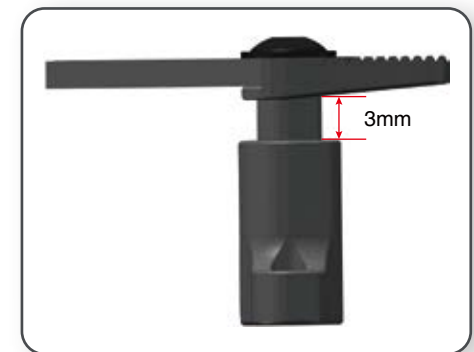

M3x16 Flanged



M3x4

## STEP 23

**OPT**

402147  
Lipomount weight  
shorty brass  
50gr (2) X20

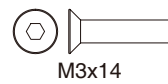
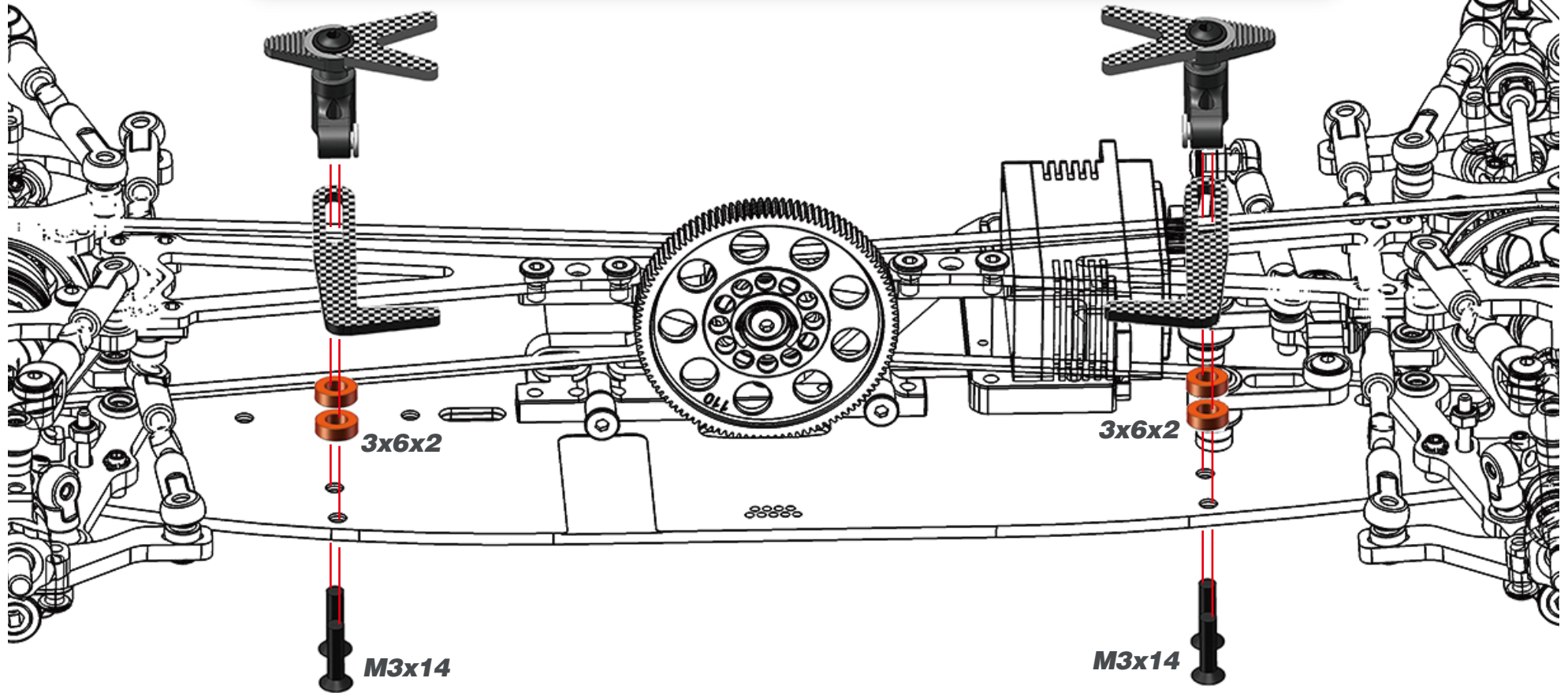

## STEP 24 SHOCK BAG

**24.1**



**24.2**



**24.3**



## 24.4



## 24.5



## 24.6



## STEP 25

### 25.1 FRONT

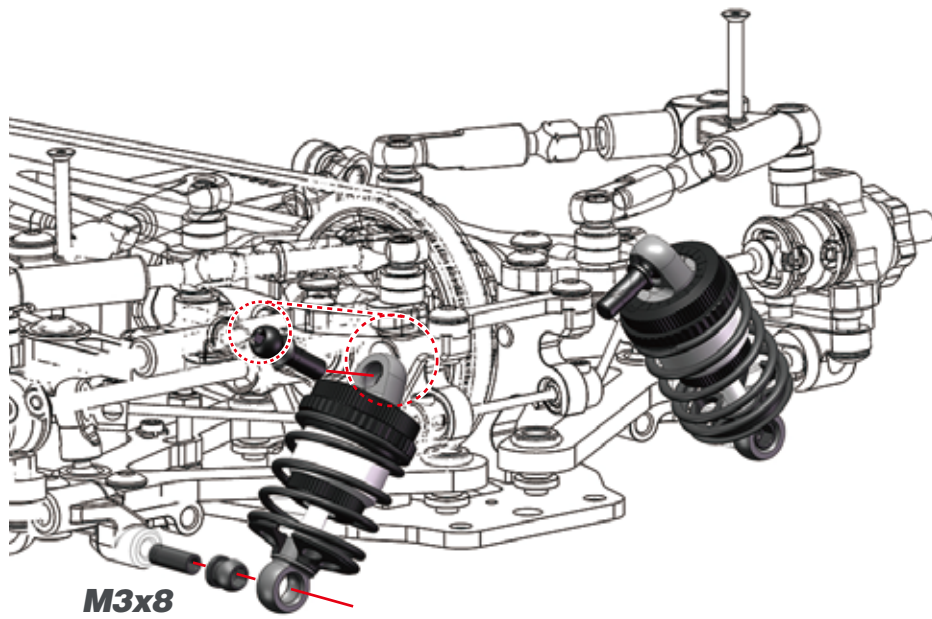

### 25.2 REAR

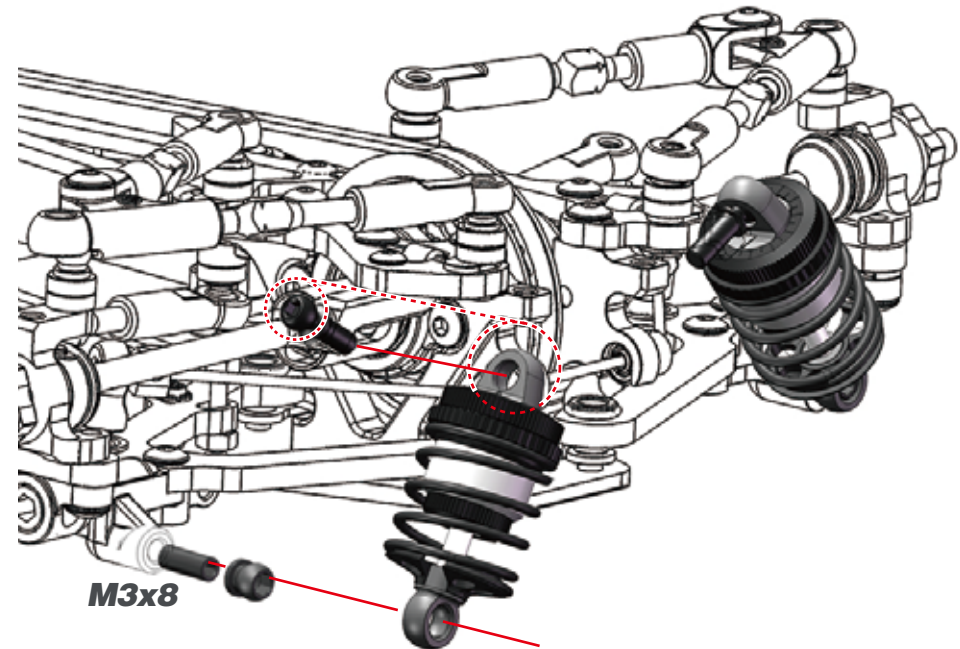

## STEP 26 BAG 7

### 26.1

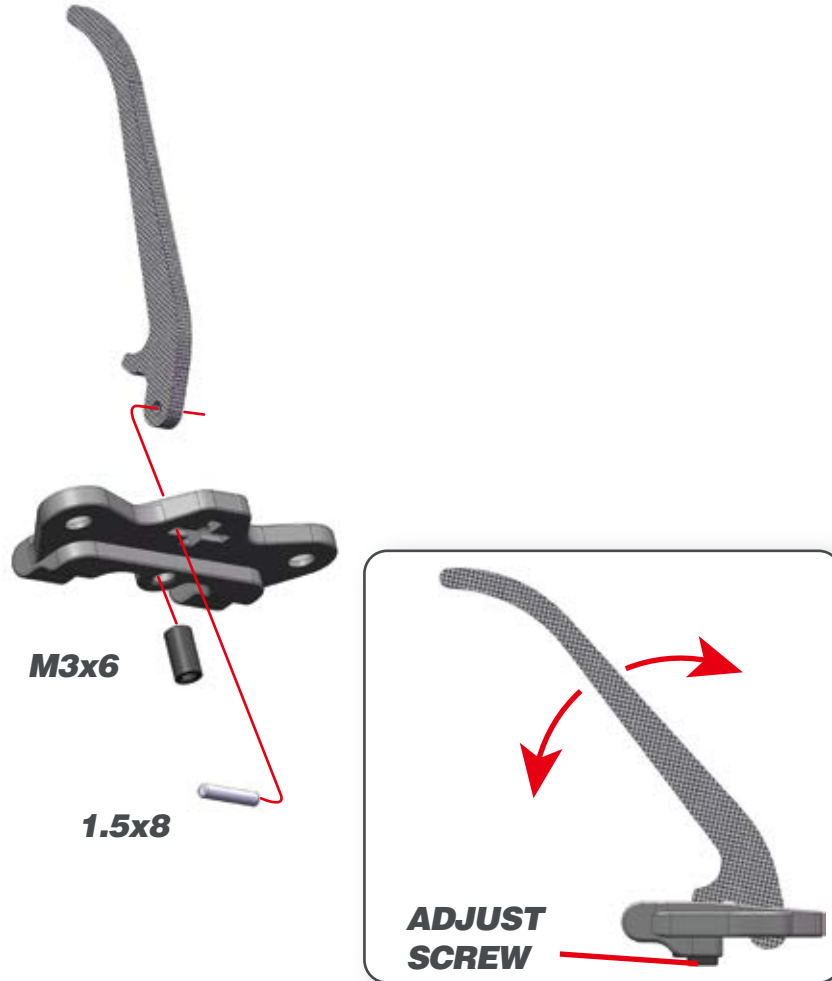

### 26.2

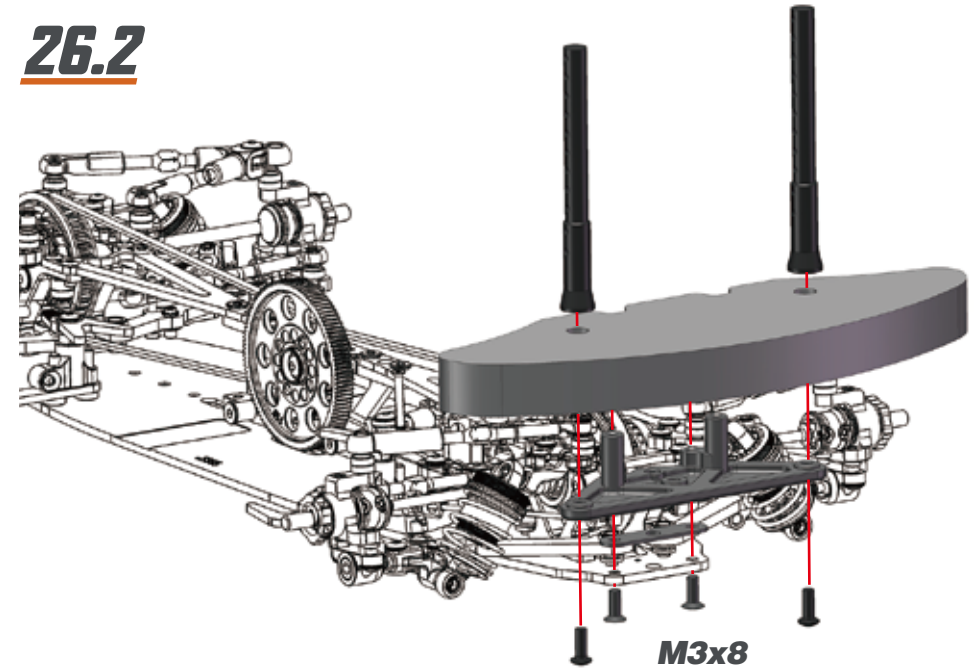

- OPT

401954 Bumper top carbon X20 '21
- OPT

401602 Body-height fine-tuner alu (4)

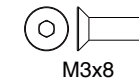
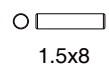

## STEP 26

### 26.3

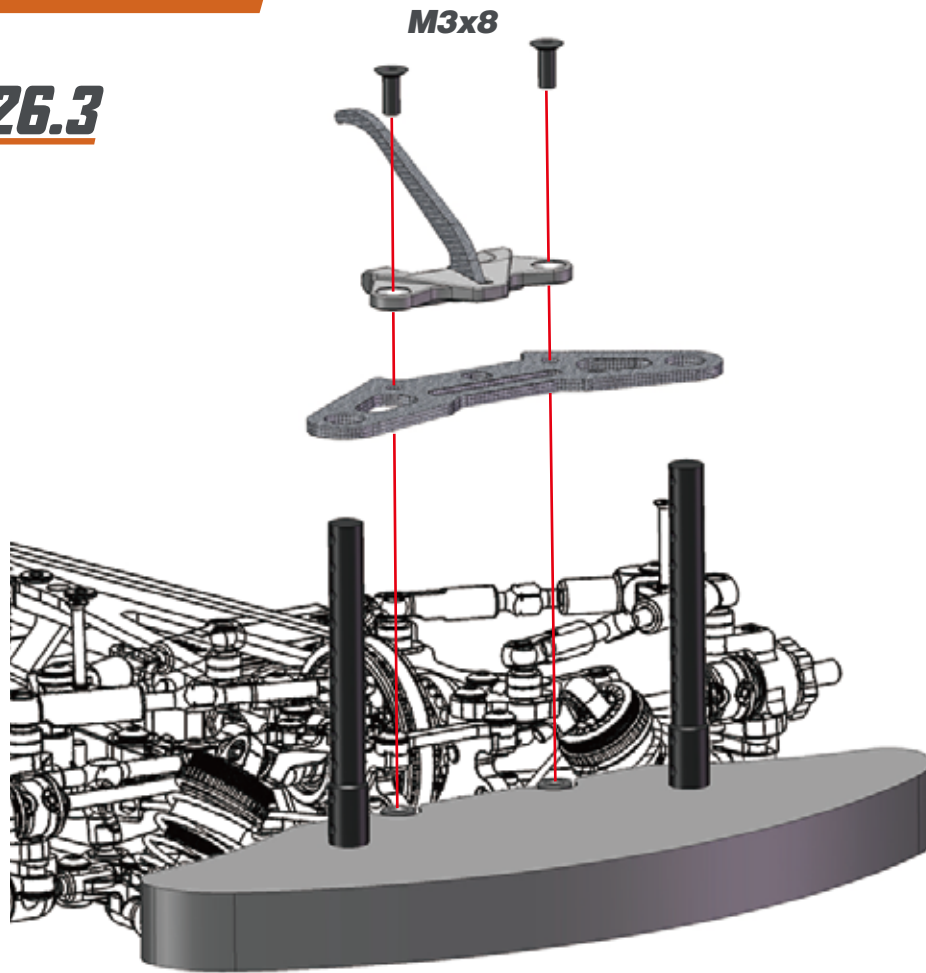

M3x8

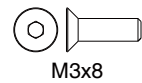

### 26.4

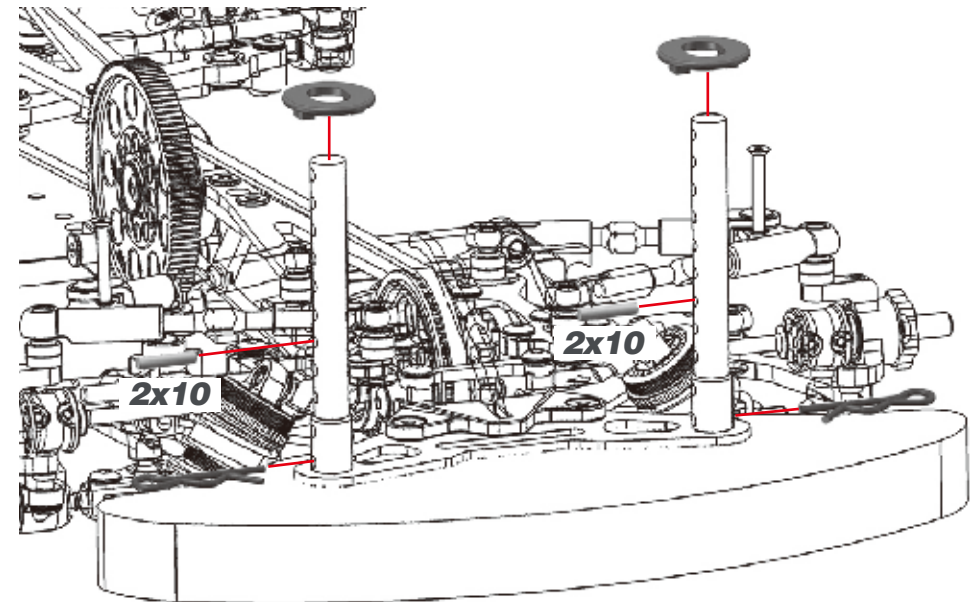

2x10

2x10

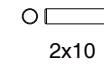

## STEP 27

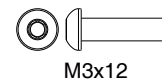
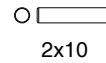
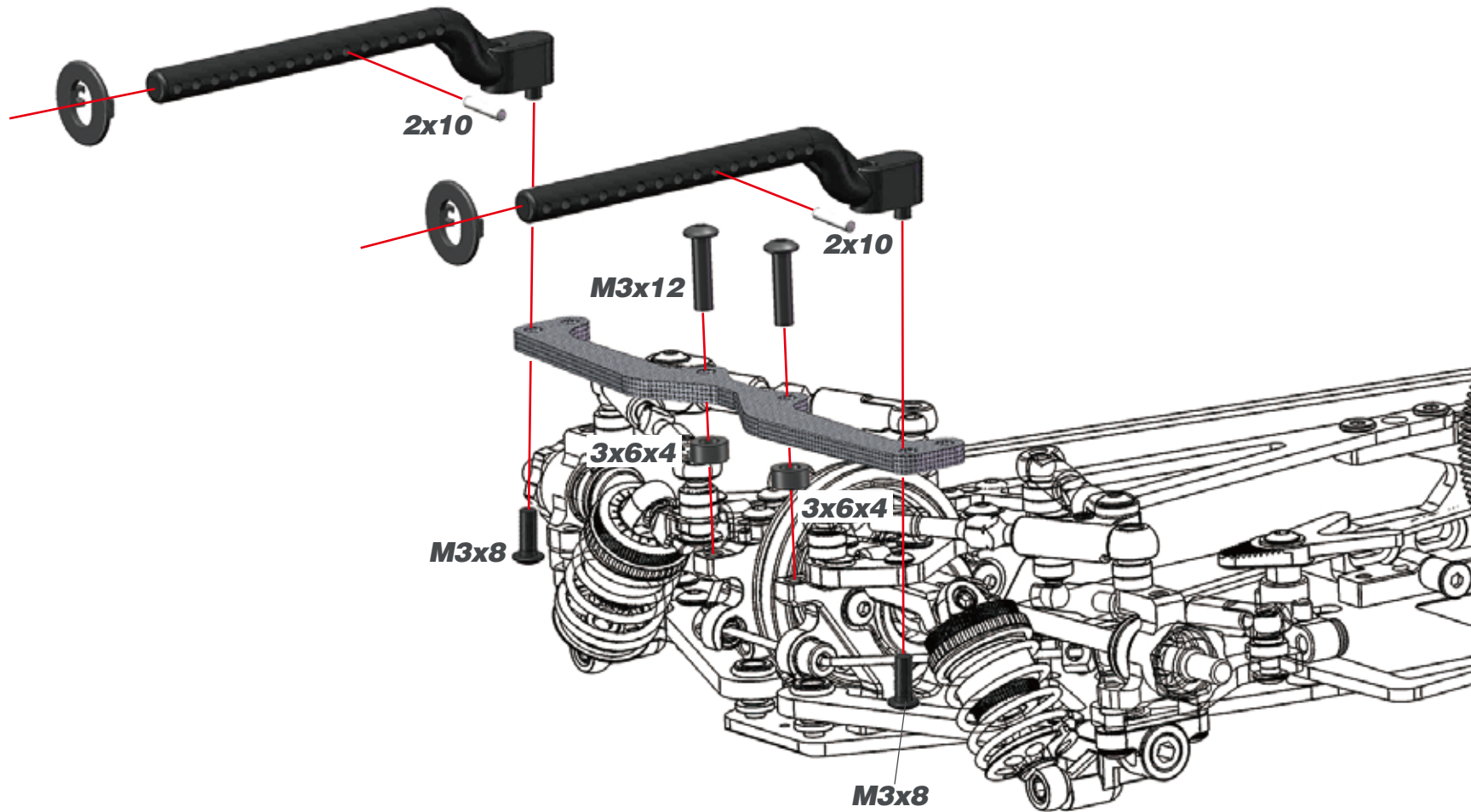

## STEP 28

### 28.1

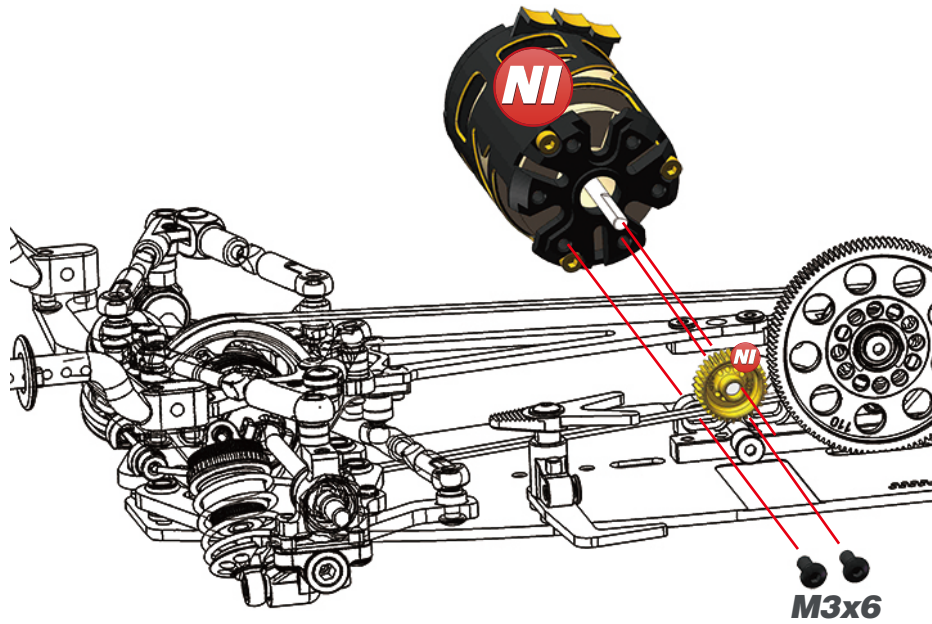

### 28.2



Lock the pinion screw from that way.

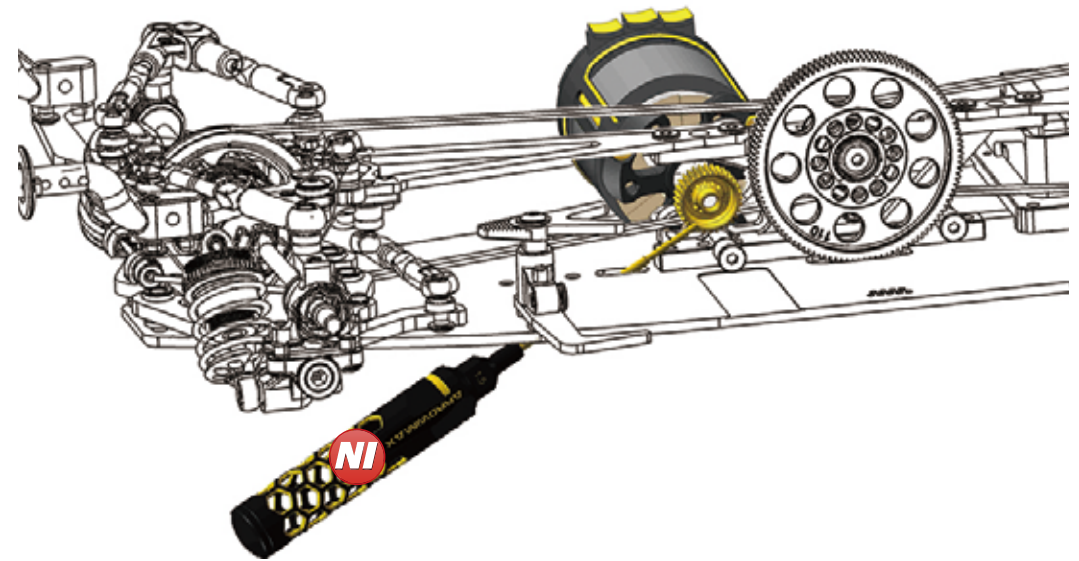

M3x6

## STEP 29

### 29.1

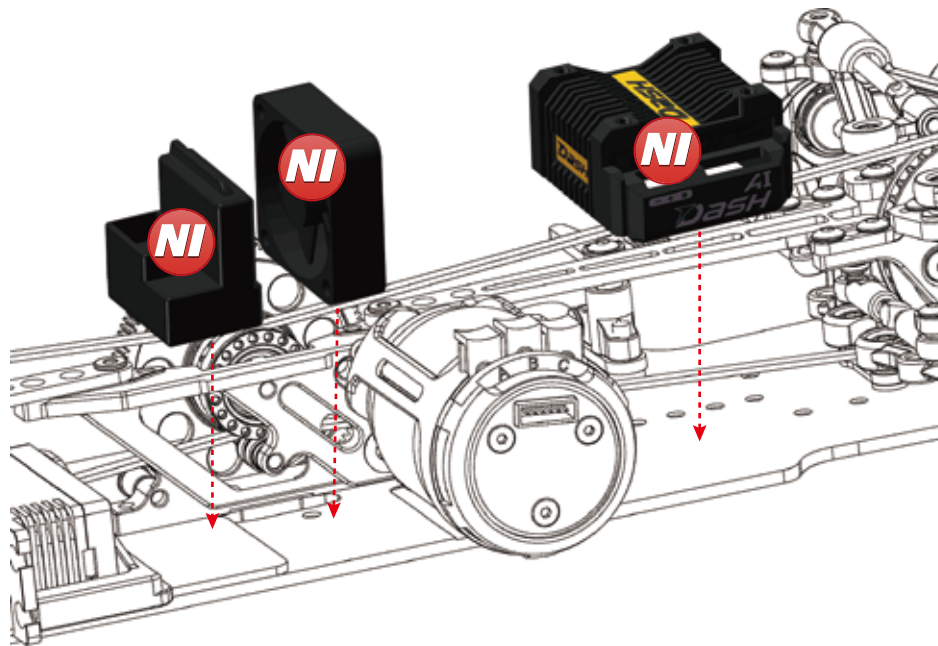

### 29.2

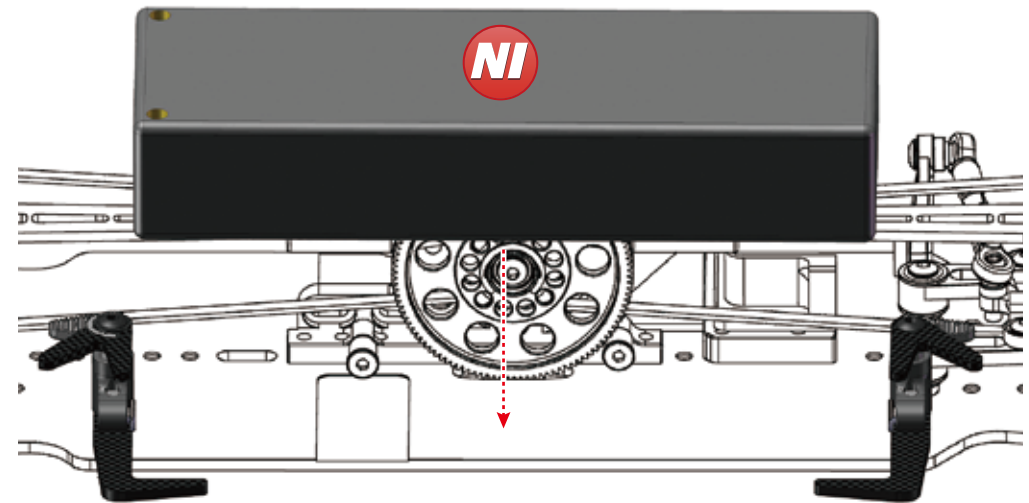
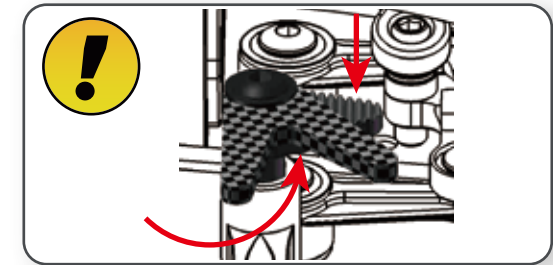

## STEP 30

### 30.1

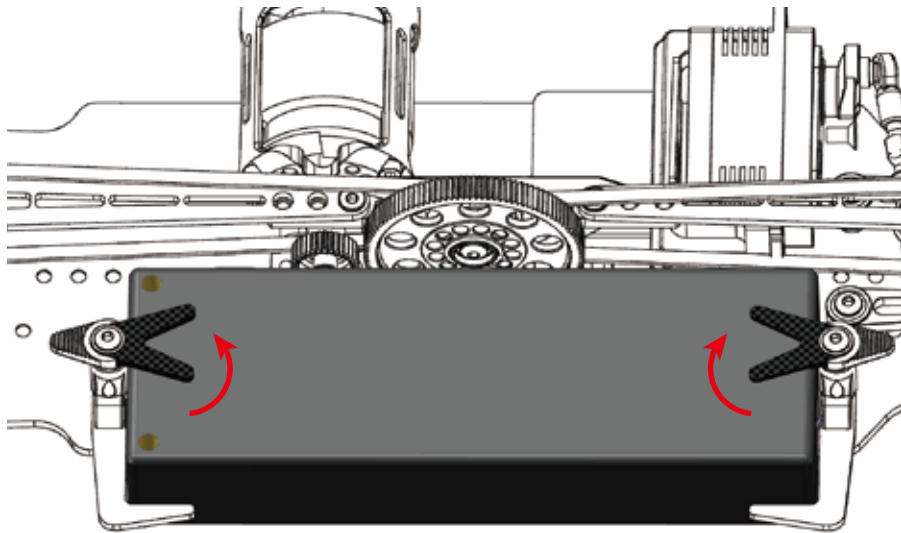

### 30.2

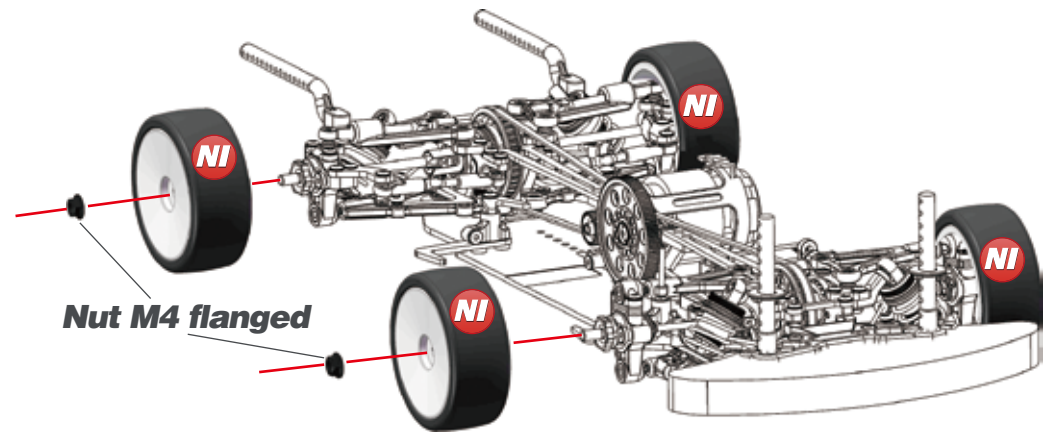

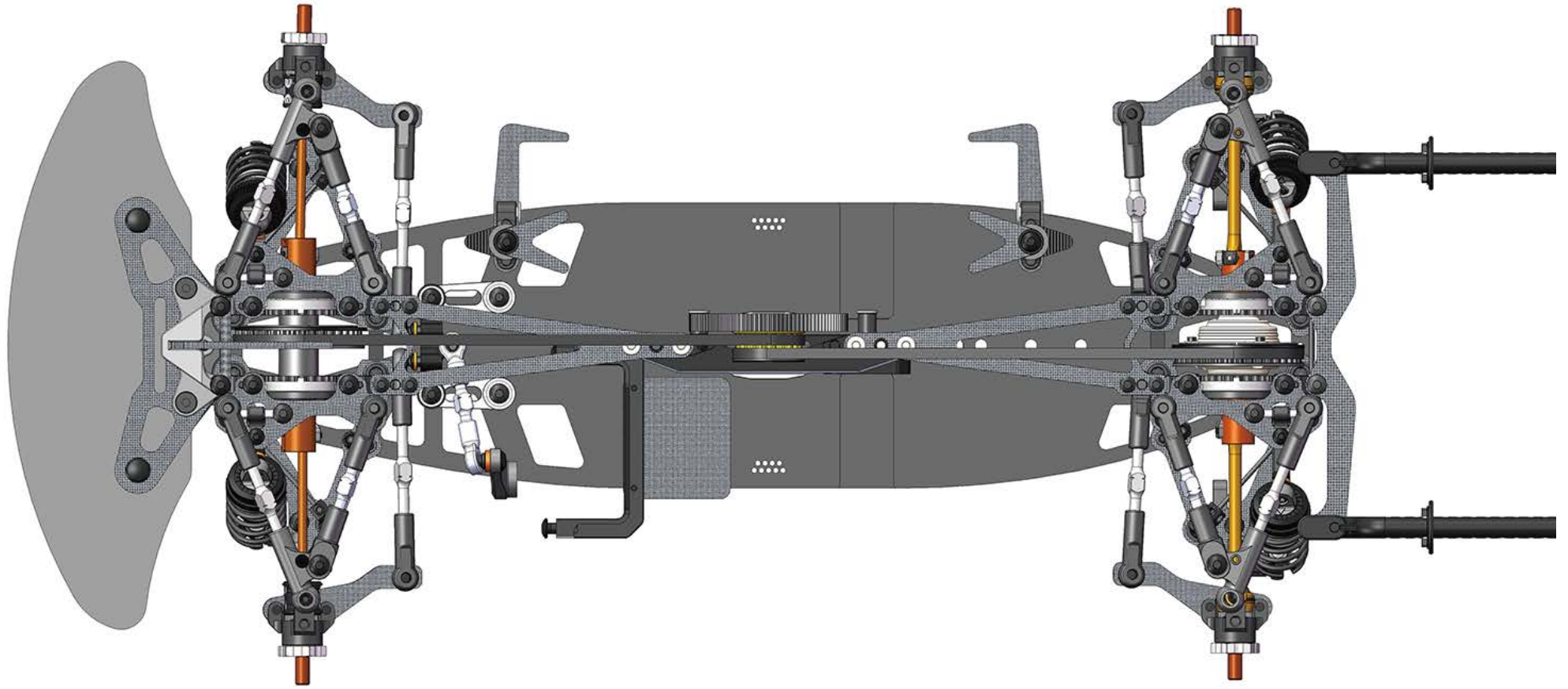

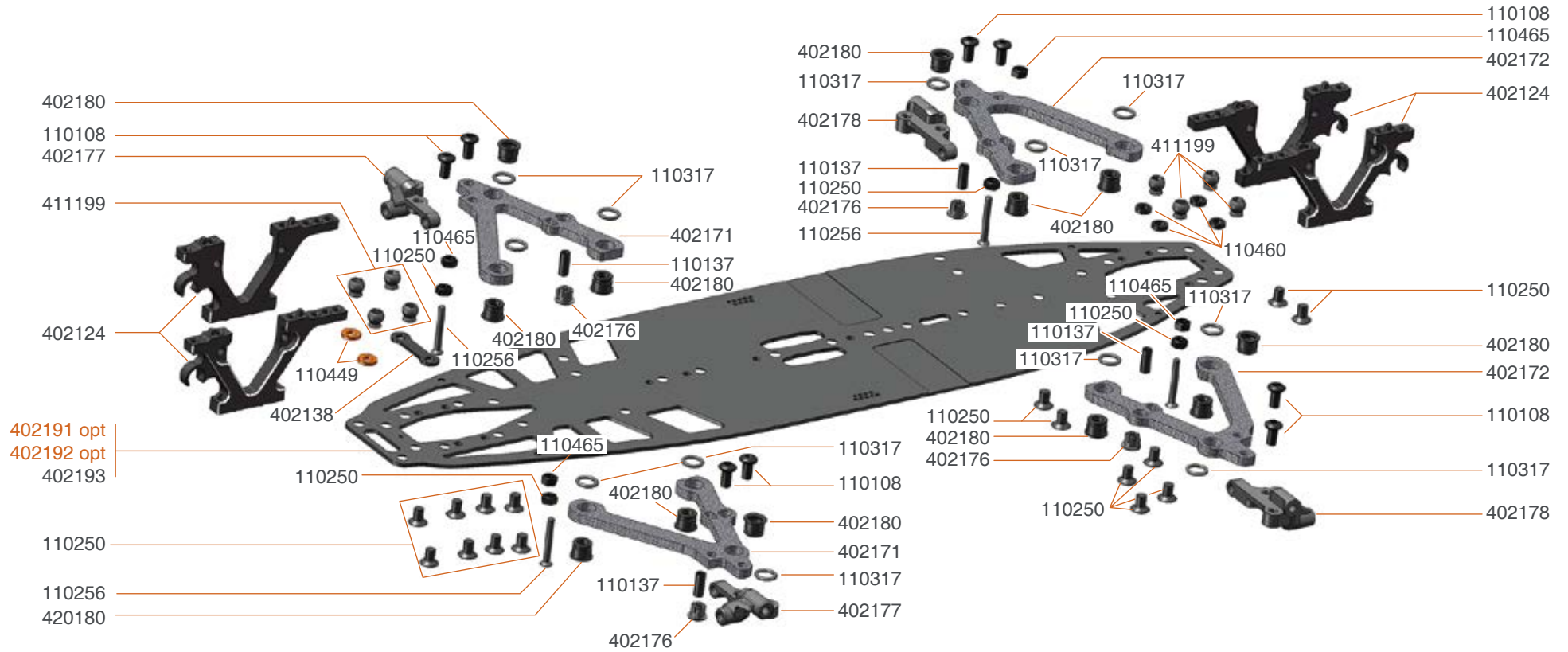

402191 Chassis alu X26  
 402192 Chassis carbon X26



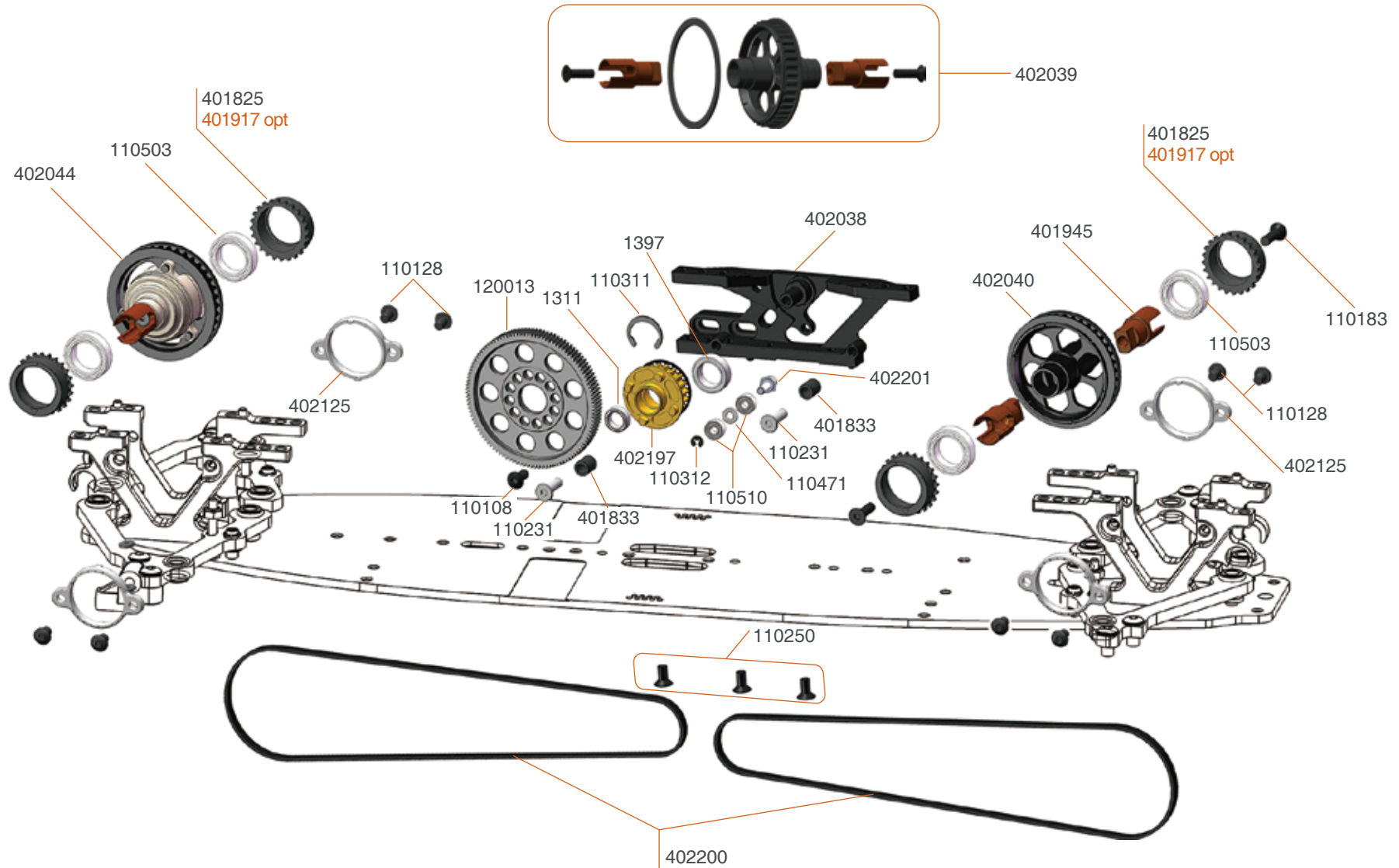

- 401917 Bearing excenter fr/r (4) alu X20
- 402066 Motormount weight 5gr X20 '23
- 402067 Motormount weight 10gr X20 '23

- 120007 Spur gear 64P / 100T
- 120008 Spur gear 64P / 104T
- 120009 Spur gear 64P / 108T
- 120010 Spur gear 64P / 112T

- 120012 Spur gear 64P / 114T
- 120013 Spur gear 64P / 116T
- 120039 Spur gear 64P / 120T

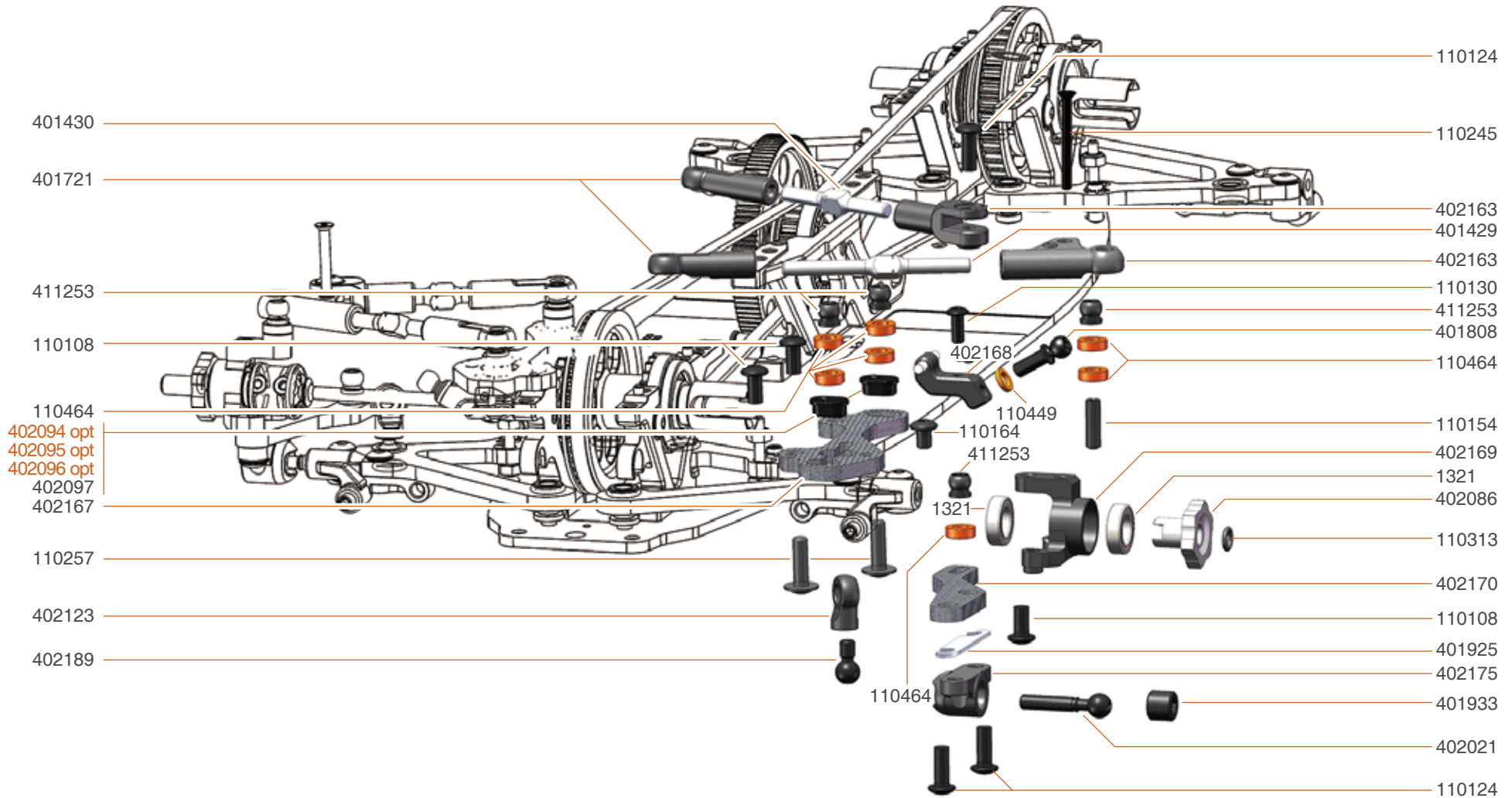

- 402094 Caster insert 0 (4) X20 '24
- 402095 Caster insert 1 (4) X20 '24
- 402096 Caster insert 2 (4) X20 '24

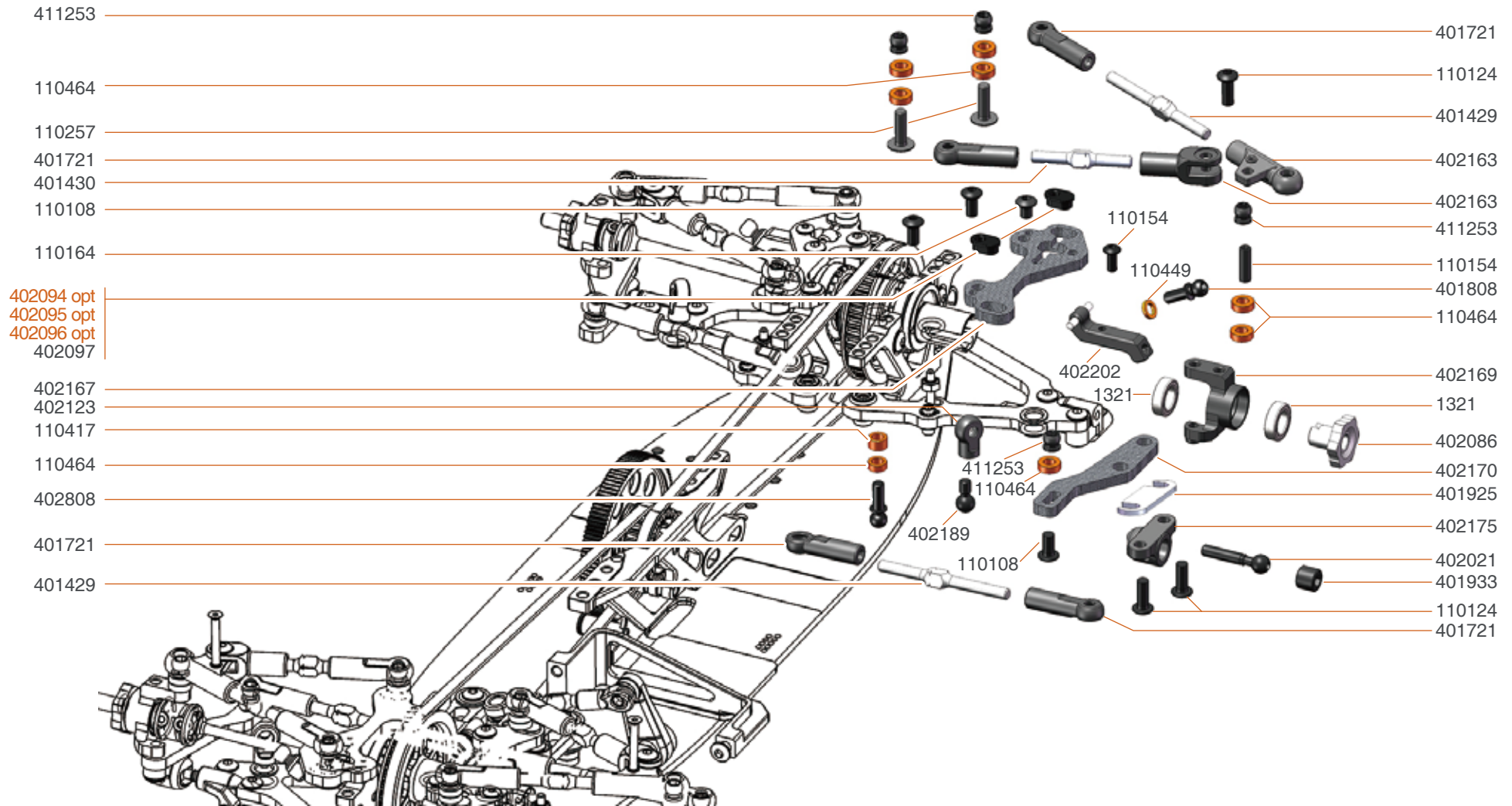

- 402094 Caster insert 0 (4) X20 '24
- 402095 Caster insert 1 (4) X20 '24
- 402096 Caster insert 2 (4) X20 '24

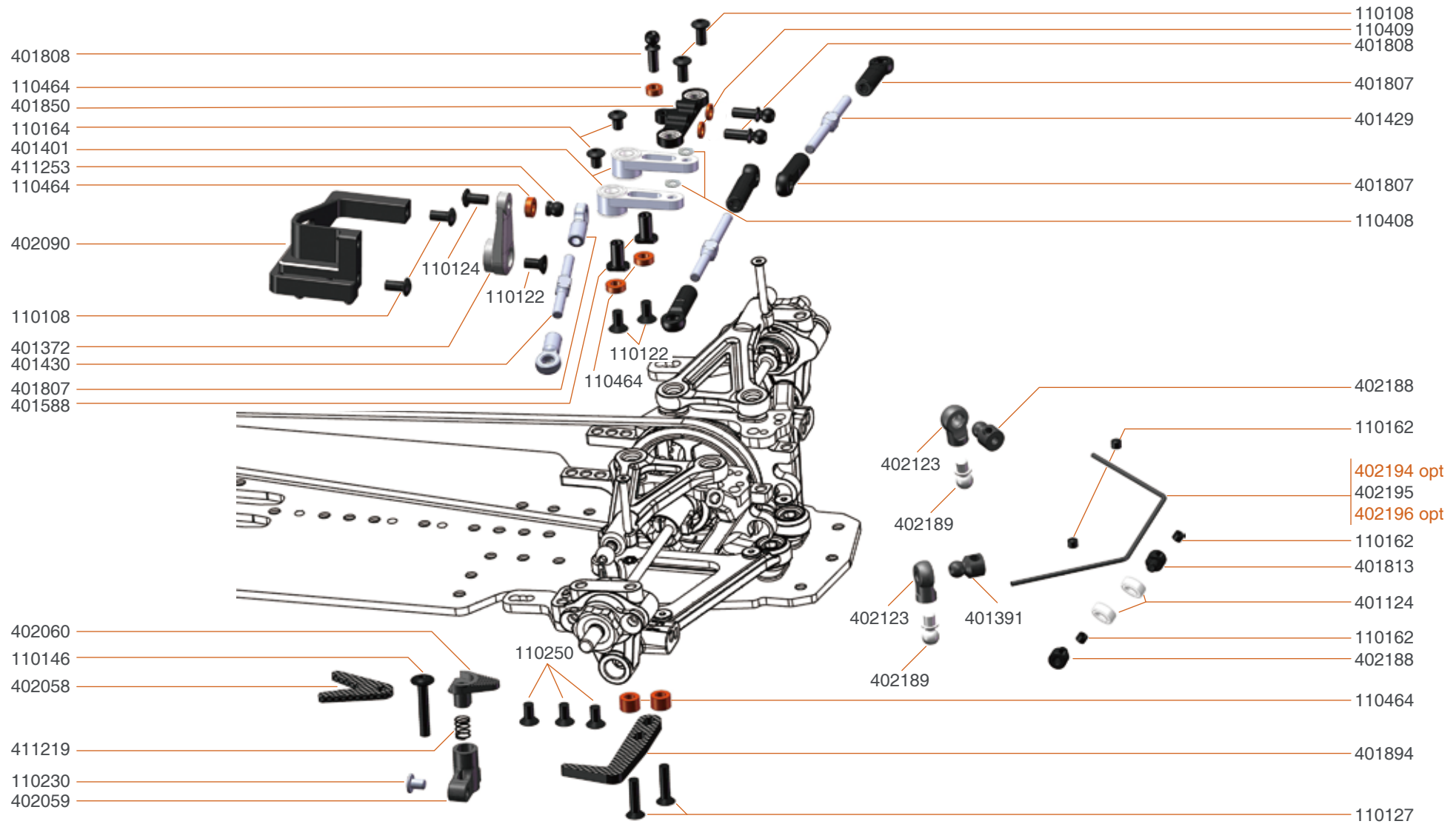

402194 Antiroll bar 1.2 X26  
402196 Antiroll bar 1.4 X26



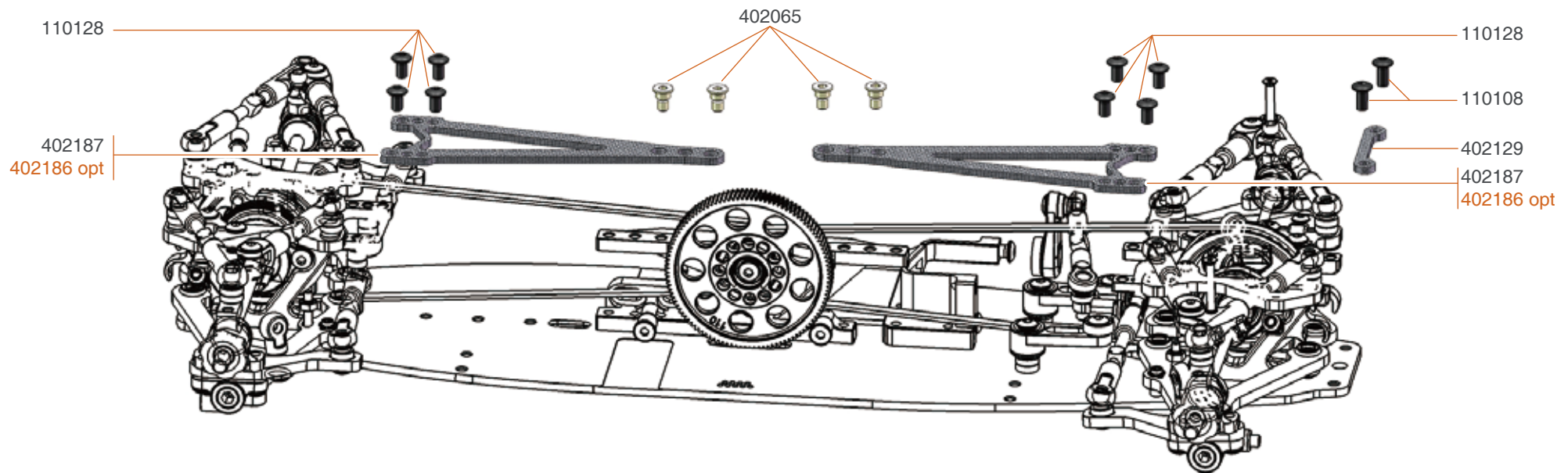

402186 Topdeck soft (2) X26



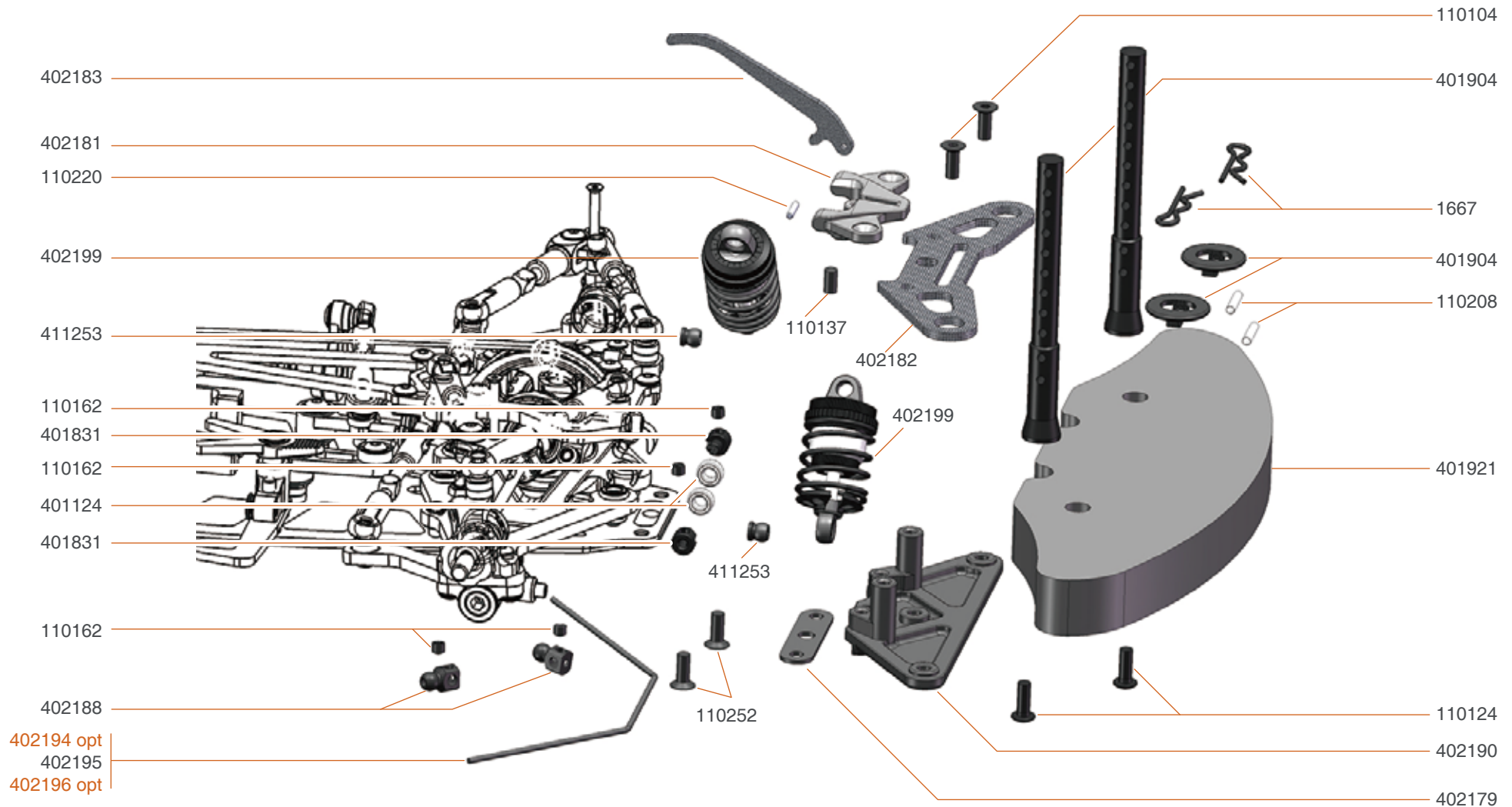

402194 Antiroll bar 1.2 X26  
 402196 Antiroll bar 1.4 X26



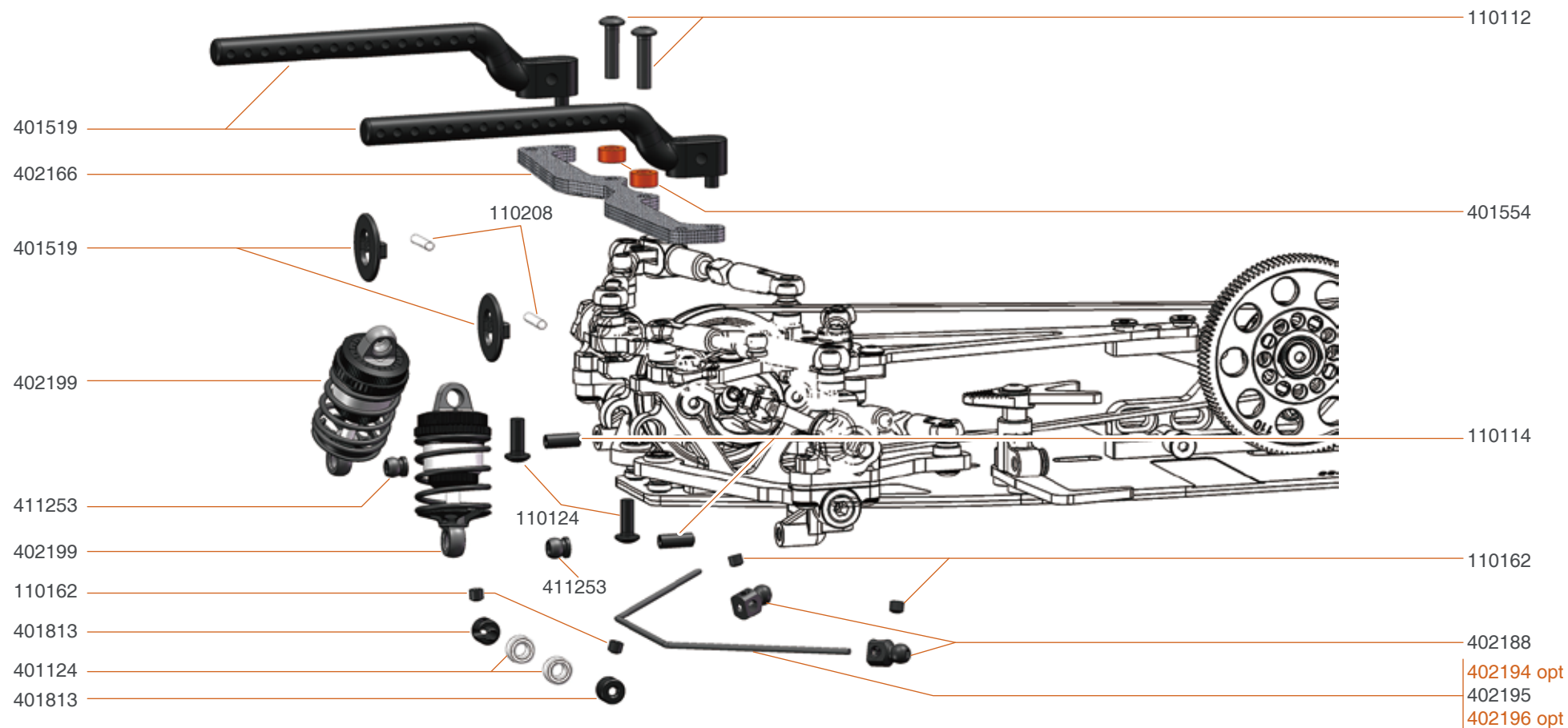

402194 Antiroll bar 1.2 X26  
 402196 Antiroll bar 1.4 X26



402081 CVD BB driveshaft set (2) X20 '24  
 402203 DJC BB driveshaft set 43mm (2) X26

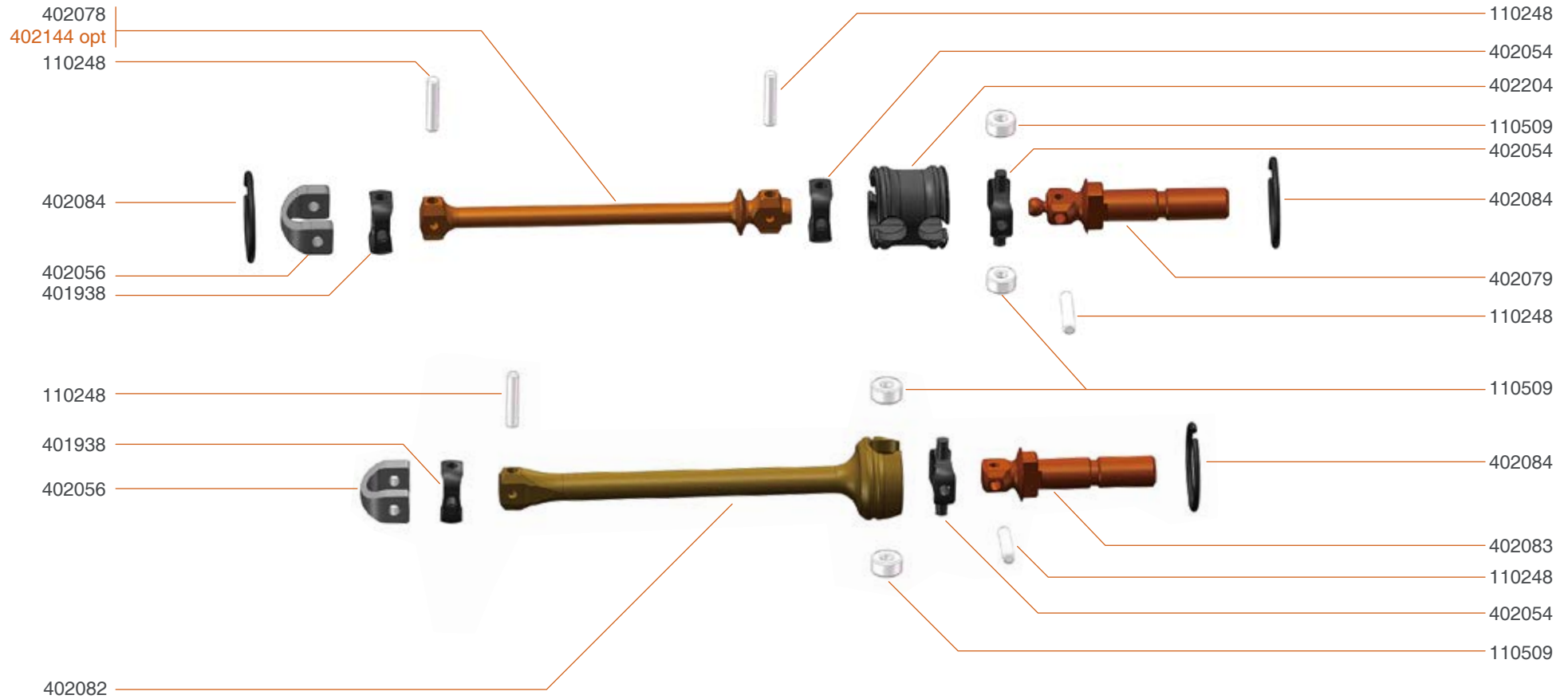

402144 DJC driveshaft BB 45mm (2) X20



## 402199 Shockset (2) X26

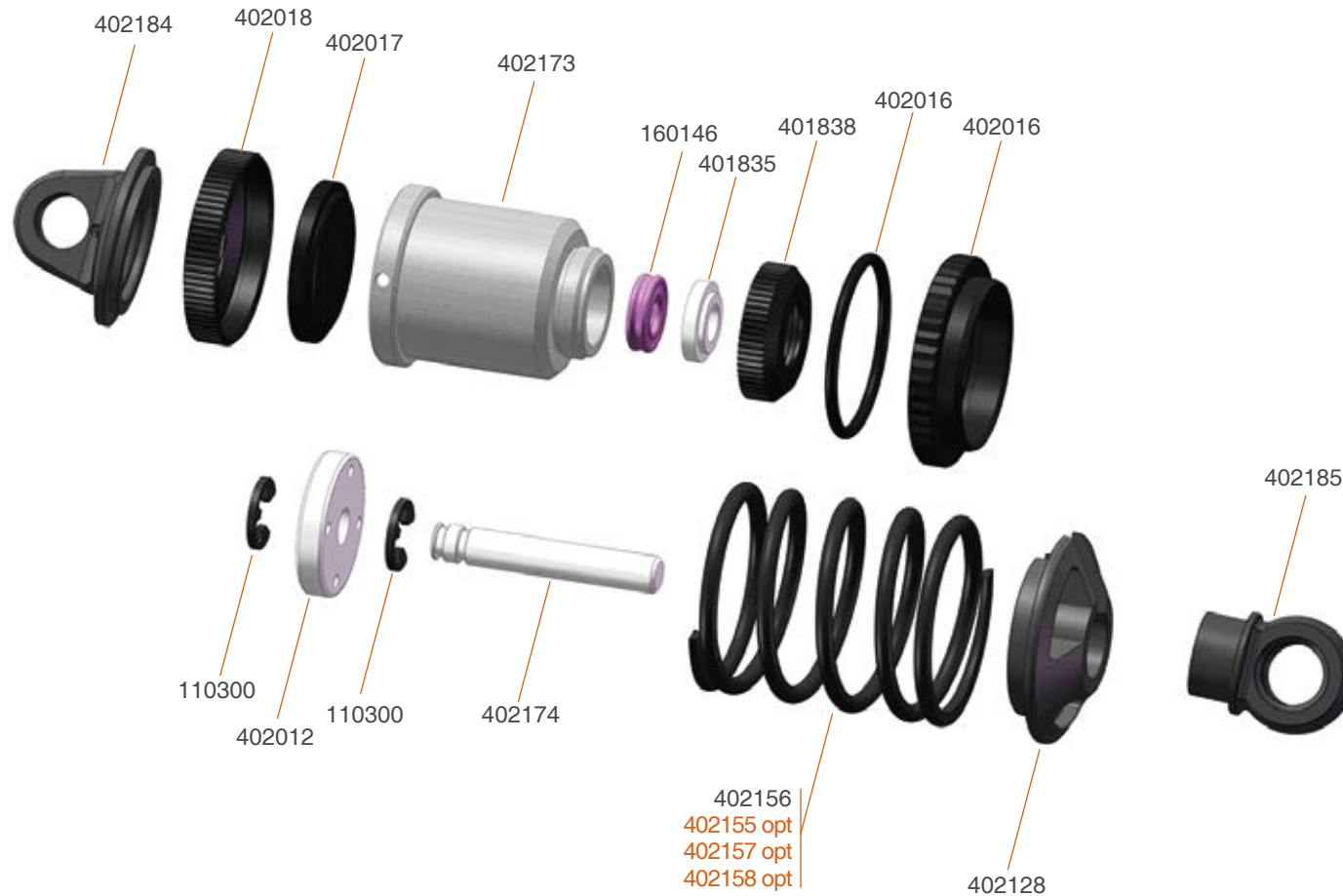

- 402155 Spring fr/r 2,5 short (2)
- 402157 Spring fr/r 2,7 short (2)
- 402158 Spring fr/r 2,8 short (2)

402044 Geardiff set alu X20 '23



401784 Seal 5x9x2 diff (2)



# TEAM SERPENT NETWORK

## X26 SPARE PARTS

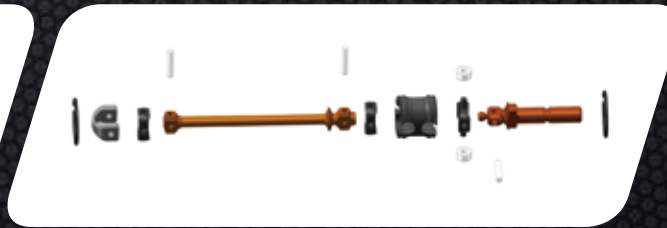

## X26 OPTIONALS PARTS

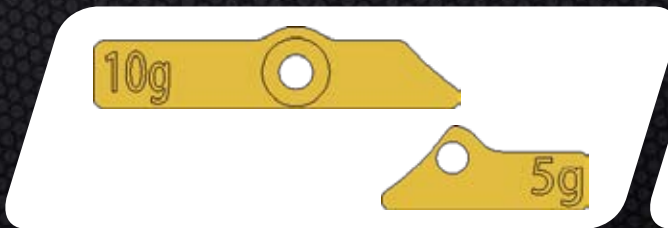

## SERPENT TOOLS



## SERPENT MERCHANDISING



## SERPENT WEBSITE AND BLOG

[www.serpent.com](http://www.serpent.com)

[www.teamserpent.com](http://www.teamserpent.com)

[www.dragon-rc.com](http://www.dragon-rc.com)

**SERPENT PROMO PAGES** <http://promo.serpent.com>

## SERPENT SOCIAL MEDIA



[www.facebook.com/SerpentMRC](http://www.facebook.com/SerpentMRC)



[www.youtube.com/user/SerpentMRC](http://www.youtube.com/user/SerpentMRC)

# X26

1/10 SCALE ELECTRIC TOURING CAR



Manual X26 steel #98872-1

SERPENT