

## SET-UP SHEET

DRIVER

RACE

TRACK

NAME

CITY/COUNTRY

DATE

TEMPERATURE AIR  TRACK

QUALIFYING POSITION BEST LAP TIME FINAL POSITION RACE LENGTH

TRACK CONDITION  CARPET  ASPHALT

TECHNICAL  MIXED  FAST

TRACTION  LOW  MEDIUM  HIGH

FRONT	REAR
TRANSMISSION	
GEAR DIFF	GEAR DIFF
<input type="checkbox"/> CST	<input type="checkbox"/> CST
<input type="checkbox"/> ONE WAY	<input type="checkbox"/> ONE WAY
<input type="checkbox"/> SPOOL	<input type="checkbox"/> SOLID

FRONT BALL DIFF	REAR BALL DIFF
<input type="checkbox"/> LOOSE <input type="checkbox"/> MEDIUM <input type="checkbox"/> TIGHT	<input type="checkbox"/> LOOSE <input type="checkbox"/> MEDIUM <input type="checkbox"/> TIGHT

PINION  T  SPUR GEAR  T

FINAL DRIVE RATIO  ROLLOUT  mm

MOTOR  TIMING

ROTOR  ARMATURE

ESC  BATTERIES

BRUSHLESS  PROGRAM  PUNCH  INITIAL BRAKE  AUTO BRAKE

BODY  WING

SHOCK ABSORBERS

FRONT  OIL  CST  SPRING

REAR  OIL  CST  SPRING

OPEN  CLOSED

ANTI-ROLL BAR THICKNESS  mm

TIRES	THICKNESS
<input type="text"/> mm	<input type="text"/> mm
<input type="text"/> mm	<input type="text"/> mm
<input type="text"/> mm	<input type="text"/> mm
<input type="text"/> mm	<input type="text"/> mm

WEIGHT: TOTAL  g

REMARKS

### FRONT

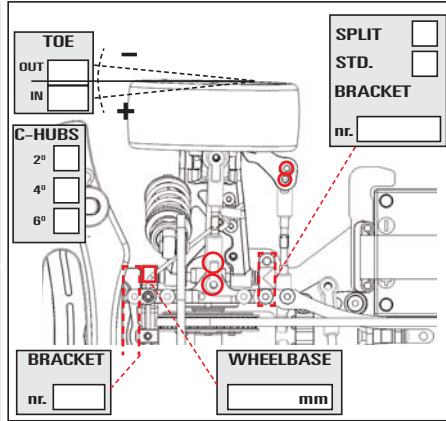

### REAR

