



# SET UP

# FIIO



RACE	Basic setup Asphalt/Rubber	DATE	
TRACK		QUALIFYING POSITION	
DRIVER		QUALIFYING TIME	
SURFACE:	ASPHALT <input checked="" type="checkbox"/> CARPET <input type="checkbox"/>	STARTING POSITION	
TRACTION:	LOW <input type="checkbox"/> MEDIUM <input type="checkbox"/> HIGH <input type="checkbox"/>	FINAL POSITION	
TRACK TEMP		AIR TEMP	

**FRONT SPRINGS (lbs)**

18

22

26

Other (brand/type): /

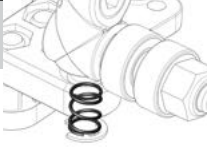

**FRONT RIDE HEIGHT SPACERS**

SPACERS 4 mm



**CENTRAL SHOCK**

Shocktower position



**CENTER SPRING**

Gray  White

Black  Yellow

Green  Orange

Other (brand/type): /

**SHOCK OIL** 500 cst

**PISTON HOLES**



**SIDE SPRINGS (lbs)**

4.5  6.0

5.0  6.5

5.5  7.0

Other (brand/type): /

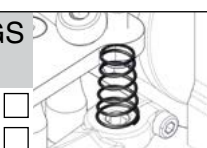

**CENTRAL TUBE**



**OIL** 30.000cst

**REAR AXLE INSERT**

0/0  0/25

0/5  0/30

0/10  0/35

0/15  0/40

0/20



**REMARKS**

## FRONT

TRACK WIDTH: STANDARD  WIDE

**ROLL CENTER AND WISHBONE ANGLE**

Shims Rear 0 mm

Shims Front 0 mm

**OFFSET**

Shims mm

**STEERING ROD POSITION**

ACKERMAN TOE-IN -1.5°

Shims 0 mm Shims 0 mm

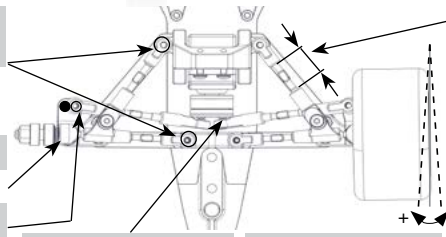

**CASTER (link length)**

Standard		Wide
15.7 mm	0° <input type="checkbox"/>	14 mm
15 mm	3° <input checked="" type="checkbox"/>	13.4 mm
14.4 mm	6° <input type="checkbox"/>	12.8 mm
13.9 mm	9° <input type="checkbox"/>	12.2 mm

**CAMBER**

R -1.5°

L -1.5°

**RIDE HEIGHT** 4 mm

WITH TYRE Ø 63mm

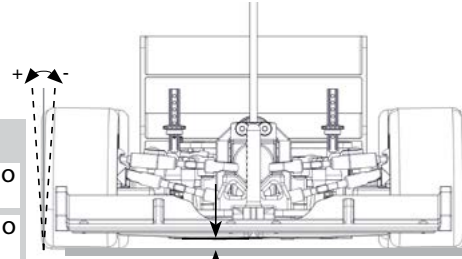

**FRONT TIRES**

Type: Rubber  Foam

Brand

Hardness

Diameter mm

Additive

Additive time min

Treated surface %

## REAR

**RIDE HEIGHT** 4.5mm

WITH TYRE Ø 63mm

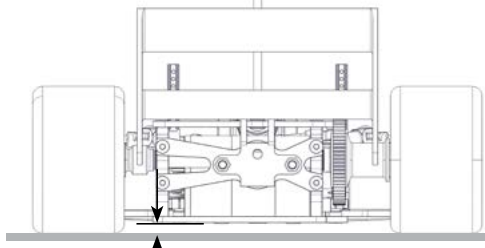

**REAR TIRES**

Type: Rubber  Foam

Brand

Hardness

Diameter mm

Additive

Additive time min

Treated surface %

**RATIO CONFIGURATION**

**SPUR GEAR**

Pitch Teeth

**PINION**

Pitch Teeth

Final drive ratio

Rollout mm

**AERODYNAMIC CONFIGURATION**

**BODY**

Brand Type

**FRONT WING**

Brand Type

**REAR WING**

Brand Type

## ELECTRONICS

**BATTERY: STANDARD**  **SHORTY**

Brand Capacity

**MOTOR**

Brand Type Timing

**ESC**

Brand Type Configuration