

ICON²

Driver: Andreas Stiebler **Track:** 5 Colli Gubbio **Event:** IFMAR WORLD CHAMPIONSHIP 2022
Date: 18.09.2022 **Qualifying:** 3 **Final:** 1 **Best Lap:** 20.124

TRACK TYPE

Grip Level High Medium Low
Type Tight Open Mixed
Condition Flat Bumpy Mixed
Surface Tarmac (Asphalt) Carpet
Track Temp 20 °C
Weather Mixed

Notes:

TYRES

Tyres HotRace HRF1A
Cleaner Additive
Additive HotRace HRADTCA
Additive Time Front: 5 mins Rear: 5 mins
Heating Time Front: mins Rear: mins
Heating Temp Front: °C Rear: °C

Notes:

Front Track width 189mm
 10 gram on rear wing mount

FRONT

KEY: CF = Carbon Fibre, AL = Aluminium, P = Plastic, F = Front, R = Rear
 H = High, L = Low, Y = Yes, N = No, V = Vertical, H = Horizontal

Ride Height 4.0 mm
Droop 5.2 mm
Toe Out ~1.5 deg **St Links** 17.8 mm
Servo Horn Height 16 mm **Saver**
Steering Travel in out
Castor ~12 deg

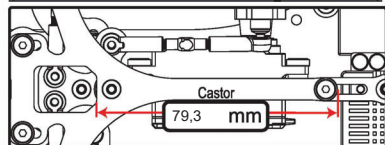

Notes:

85% Steering (100% is max)

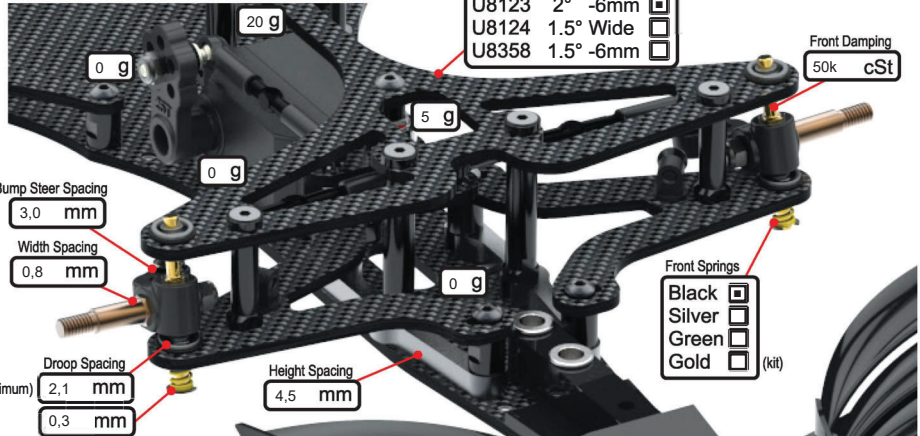

REAR

KEY: CF = Carbon Fibre, AL = Aluminium, P = Plastic, F = Front, R = Rear
 H = High, L = Low, Y = Yes, N = No, V = Vertical, H = Horizontal

Ride Height 4.2 mm
Droop 6.5 mm
Track width 190 mm
Diff Type Gear Ball Spool
Diff Oil (Gear Diffs) 2000 cSt

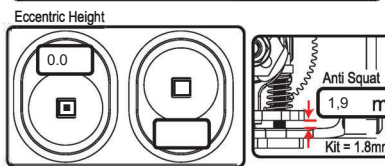

Notes:

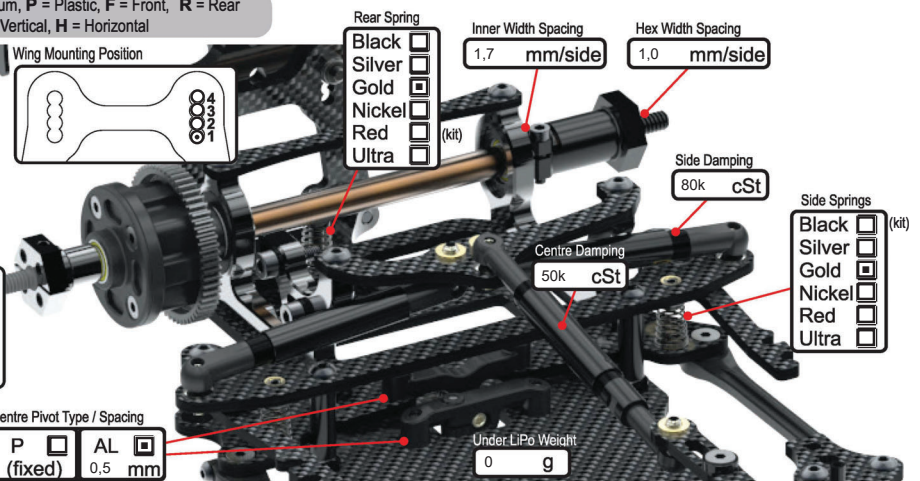

BODYSHELL

Body Gonzo
Rear Wing SER411355
Rear Wing Height 100 mm
Front Wing Montech 2022
Front Wing Flaps none
Front Post Hole #
Front Post Hanger #
Rear Post Hole # 7
Rear Post Hanger # 3
Wing Offset Rwrld -9 mm
Body Weight 40 g

CHASSIS

Chassis AL CF
Wheelbase
 Short Long
Total Weight 1047 g
Weight Distribution
 F : R
Mass Dampers
 F cSt
 R cSt

Notes:

ELECTRONICS

E.S.C. Xerun XR10 Stock Spec 80A
Servo Highest BLP650
RX Sanwa RX-492
LiPo Sunpadow Platin 5400mAh
Motor Hobbywing XeRun V10 G4 21.5T
Rotor Dia. mm
Timing 40 deg
Gear Pitch 48 64
Pinion 41 t
Spur 88 t
Ratio 2.15

Notes:

25mm Fan on the left side in the back
 Serpent rear wing [SER411355] high downforce config