

Driver Details	
NAME	
DATE	
EVENT / TRACK	
WEATHER	
RESULT	
FASTEST LAP TIME	
Chassis and Electrics	
BODYSHELL	
WING	
E.S.C	
SERVO	
RECEIVER	
LIPO	
Track Conditions	
GRIP LEVEL	High <input type="checkbox"/> Medium <input type="checkbox"/> Low <input type="checkbox"/>
LAYOUT	Tight <input type="checkbox"/> Open <input type="checkbox"/> Mixed <input type="checkbox"/>
COMPOSITION	Carpet <input type="checkbox"/> Tarmac <input type="checkbox"/>
SURFACE	Smooth <input type="checkbox"/> Bumpy <input type="checkbox"/>
TEMPERATURE - AIR	°C °F TRACK °C °F
VENUE	Indoor <input type="checkbox"/> Outdoor <input type="checkbox"/>
TRACK DIMENSIONS	
Motor and Gearing	
MOTOR	
TIMING	
SPUR SIZE	
PINION SIZE	
Rollout	mm/rev

<b>NOTES</b>	

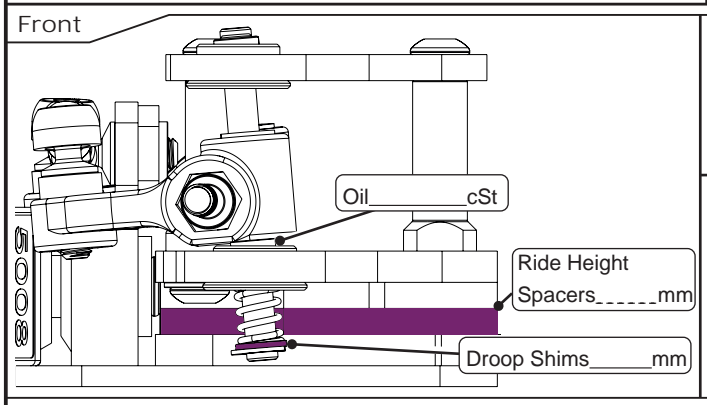

Am0 - Petitr



Ride Height \_\_\_\_\_ mm  
Droop \_\_\_\_\_ mm  
Inside wheel lock \_\_\_\_\_ °  
Toe \_\_\_\_\_ °

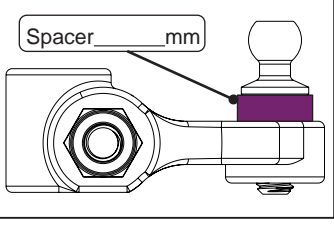

1 Dot <input type="checkbox"/>		Black <input type="checkbox"/>
2 Dot <input type="checkbox"/>		Silver - Kit <input type="checkbox"/>
3 Dot <input type="checkbox"/>		Green <input type="checkbox"/>
		Gold <input type="checkbox"/>

0 Dot - Kit <input type="checkbox"/>
1 Dot <input type="checkbox"/>
2 Dot <input type="checkbox"/>
3 Dot <input type="checkbox"/>

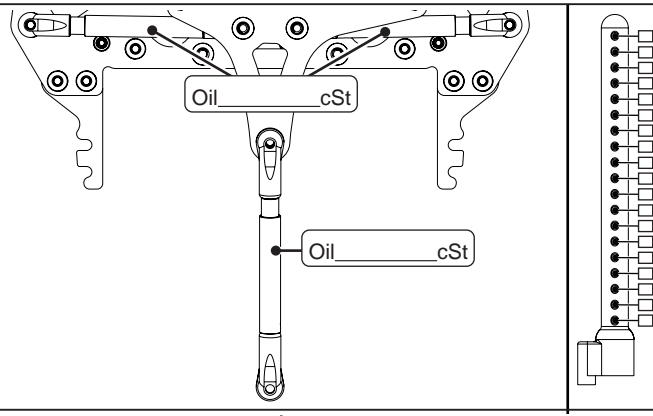
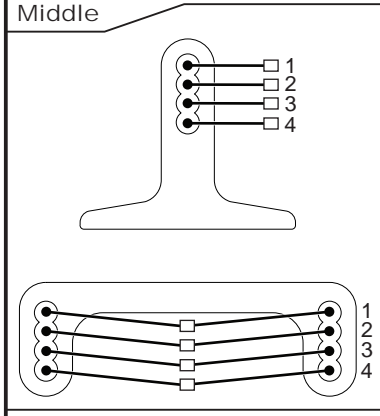

1 Dot <input type="checkbox"/>		Black <input type="checkbox"/>
2 Dot <input type="checkbox"/>		Silver - Kit <input type="checkbox"/>
3 Dot <input type="checkbox"/>		Gold <input type="checkbox"/>
		Nickel <input type="checkbox"/>
		Red Dot <input type="checkbox"/>
		Black Ultra <input type="checkbox"/>

Plastic - Kit <input type="checkbox"/>
Alloy <input type="checkbox"/>

Spacer \_\_\_\_\_ mm

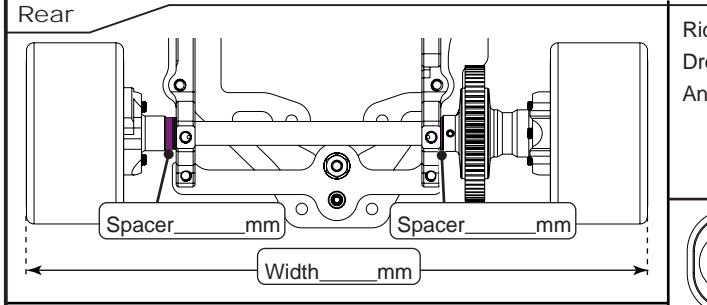

Ride Height \_\_\_\_\_ mm  
Droop \_\_\_\_\_ mm  
Antisquat \_\_\_\_\_ mm Kit (4.2mm)

Antisquat

	Black <input type="checkbox"/>
	Silver - Kit <input type="checkbox"/>
	Gold <input type="checkbox"/>
	Nickel <input type="checkbox"/>
	Red Dot <input type="checkbox"/>
	Black Ultra <input type="checkbox"/>

