

DRIVER: _____	TRACK: _____	TRANSMITTER: _____	BATTERY: _____	TIRES: _____
DATE: _____	SURFACE: ASPHALT <input type="radio"/> CARPET <input type="radio"/>	RECEIVER: _____	MOTOR: _____	ADDITIVE: _____
OUTSIDE TEMPERATURE °C: _____	LAYOUT: TECHNICAL <input type="radio"/> MIXED <input type="radio"/> FAST <input type="radio"/>	SERVO: _____	PINION TYPE & T: _____	WARMER C°: _____
TRACK TEMPERATURE °C: _____	TRACTION: LOW <input type="radio"/> MEDIUM <input type="radio"/> HIGH <input type="radio"/>	STEERING EXPO: _____	SPUR TYPE & T: _____	WARMER TIME: _____
VER. 3101-1	RACE: _____ RESULT: _____	STEERING SPEED: _____		SIDEWALL GLUE: _____

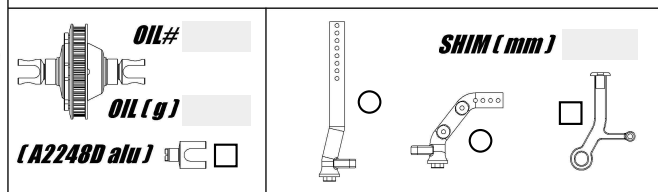

INFO

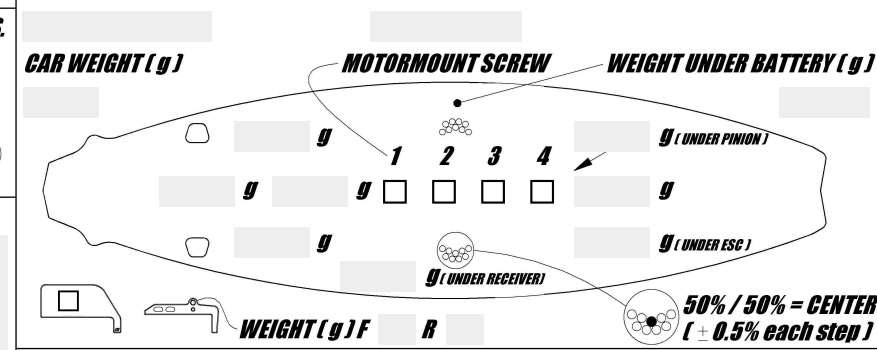
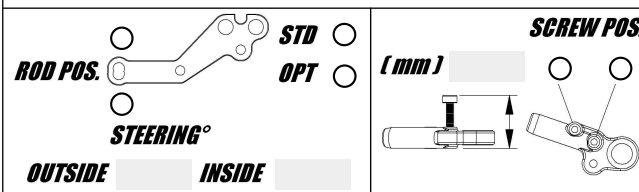
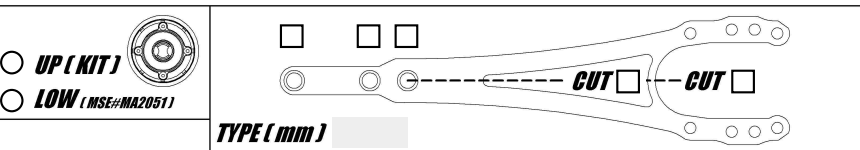
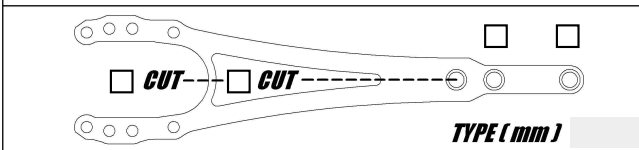
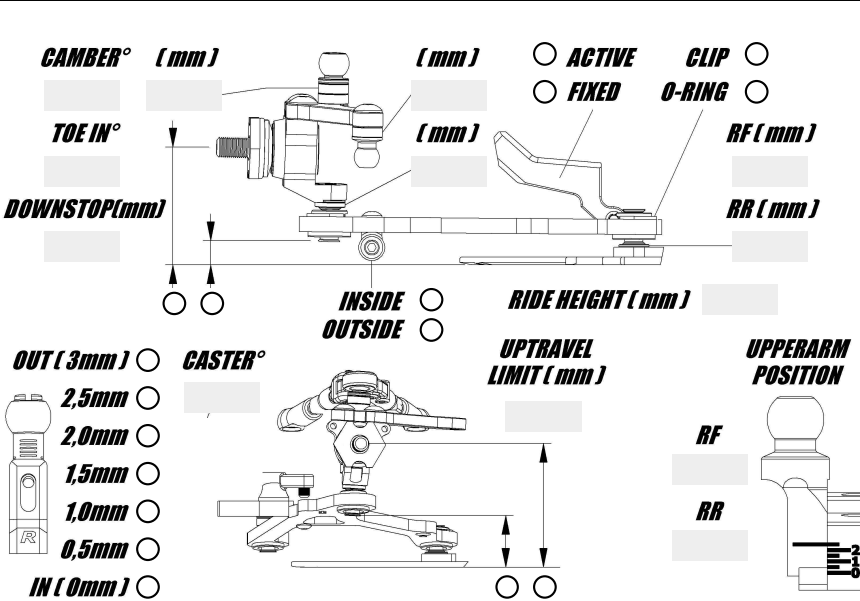
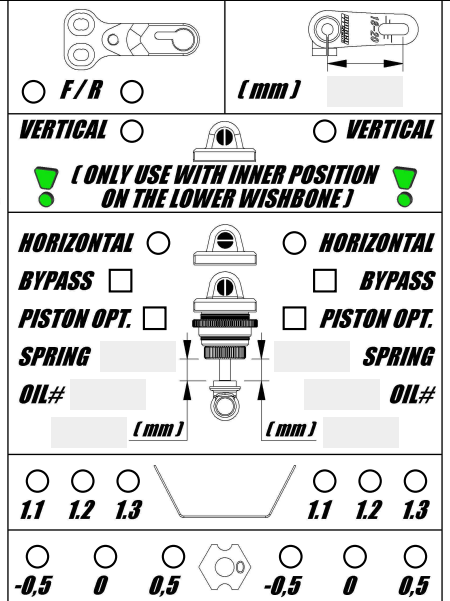
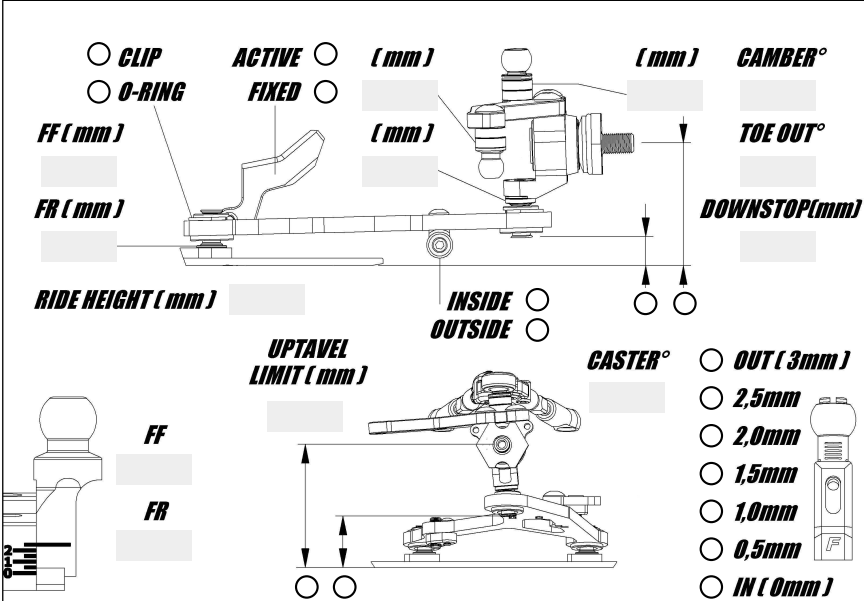