

DRIVER: _____
 DATE: _____
 OUTSIDE TEMPERATURE °C: _____
 TRACK TEMPERATURE °C: _____
 VER. 3101-1

TRACK: _____
 SURFACE: ASPHALT CARPET
 LAYOUT: TECHNICAL MIXED FAST
 TRACTION: LOW MEDIUM HIGH
 RACE: _____ RESULT: _____

TRANSMITTER: _____
 RECEIVER: _____
 SERVO: _____
 STEERING EXPO: _____
 STEERING SPEED: _____

BATTERY: _____
 MOTOR: _____
 PINION TYPE & T: _____
 SPUR TYPE & T: _____

TIRES: _____
 ADDITIVE: _____
 WARMER C°: _____
 WARMER TIME: _____
 SIDEWALL GLUE: _____

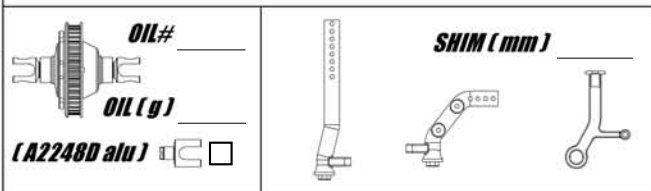
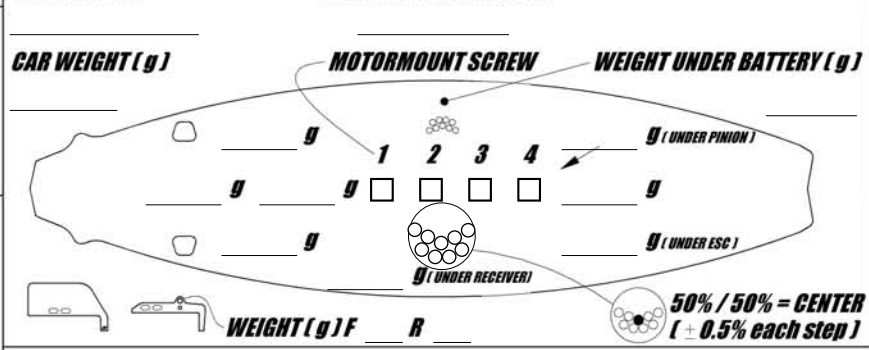
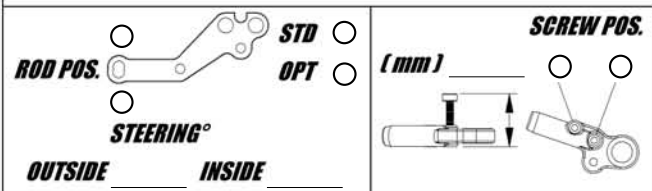
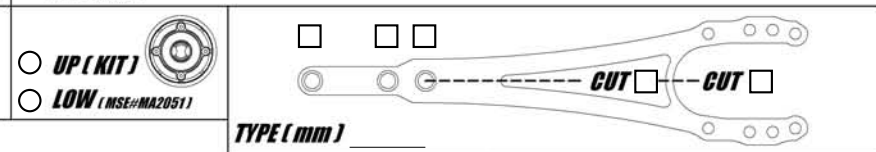
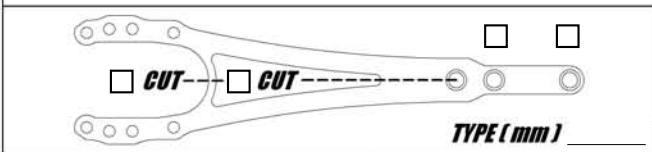
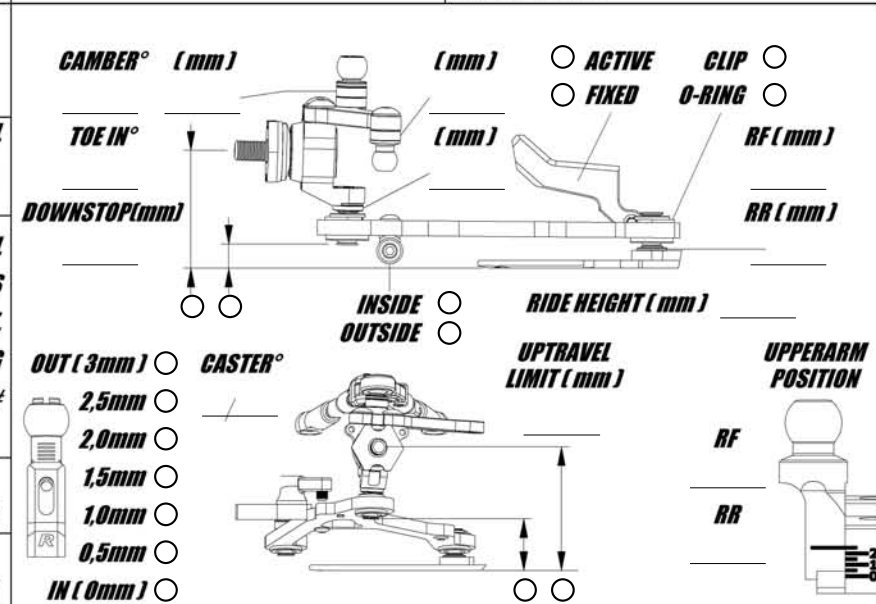
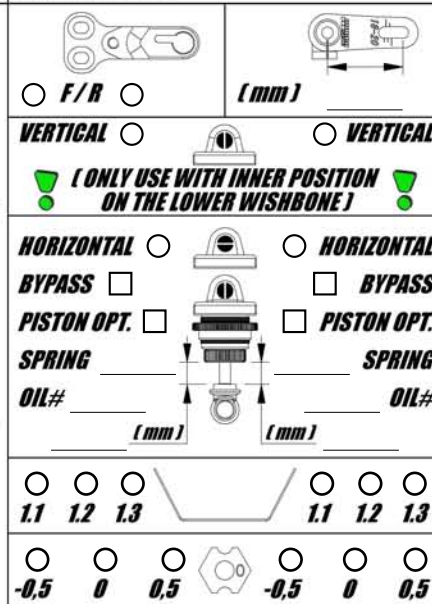
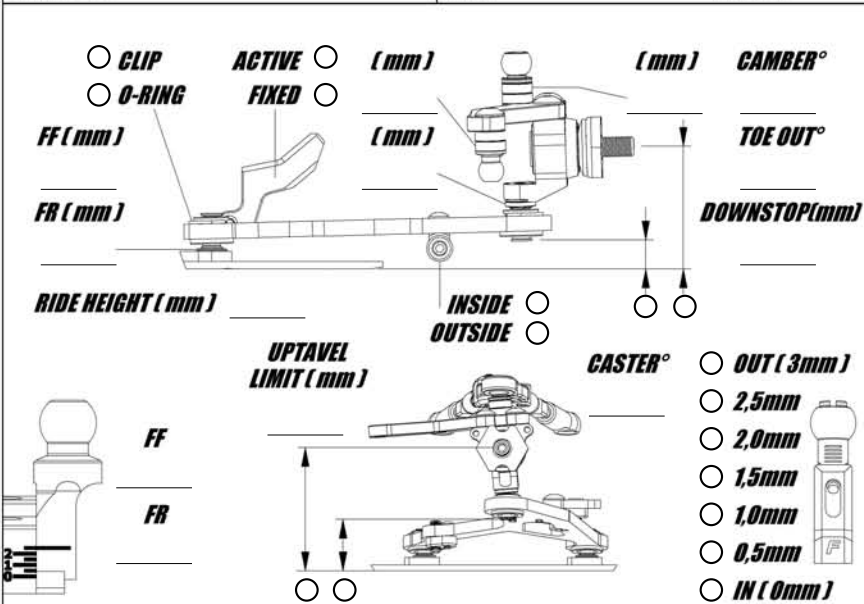

INFO

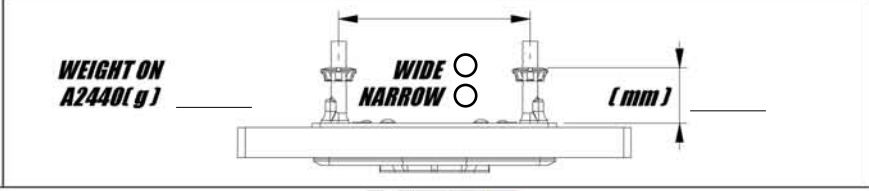

FRONT ←



→ REAR