

| | | |
|---|---|--|
| DRIVER | | |
| DATE | | |
| TRACK | Carpet <input type="radio"/> Asphalt <input type="radio"/> | |
| TRACTION | <input type="radio"/> LOW <input type="radio"/> MEDIUM <input type="radio"/> HIGH | |
| LAYOUT | <input type="radio"/> SLOW <input type="radio"/> MIXED <input type="radio"/> FAST | |
| TEMP °C | AIR | TRACK |
| ELECTRONICS | | |
| ESC | ESC SET | MOTOR |
| SERVO | RECEIVER | BATTERY |
| TIRES | | |
| BRAND | | |
| TYPE | | |
| ADDITIVE | | |
| WARMER °C | FRONT | REAR |
| TIME(min) | FRONT | REAR |
| SHOCK ABSORBERS | | |
| PISTON | FRONT | REAR |
| SHOCK CASE | | |
| OIL | | |
| SPRING | | |
| LENGTH | | |
| ANTI ROLL BAR DIAMETER FRONT/REAR | | |
| FRONT | | REAR |
| REAR DIFFERENTIAL | | |
| DIFF OIL CST (1,6g oil qty.) | | |
| GEAR RATIO (T)Spur/(T)Pinion*1,9=Ratio | | |
| PINION | | SPUR |
| AERODYNAMIC SETTINGS | | |
| BODY TYPE | | |
| WING TYPE | | |
| WING POS | (mm) | |
| BODY POSITION (see picture below) | (mm) \leftrightarrow horizontal | |
| FRONT BODY HEIGHT & POSITION | REAR BODY POST A2407C <input type="radio"/> | REAR BODY POST A2416B <input type="radio"/> |
| | | |
| (mm) vertical \updownarrow | (mm) | (mm) |
| | | |

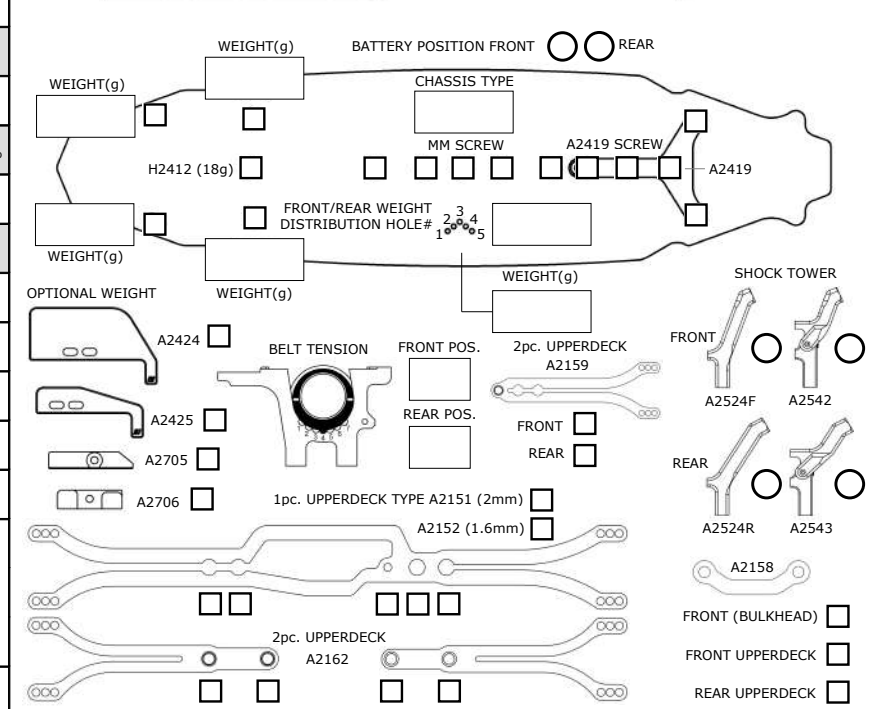
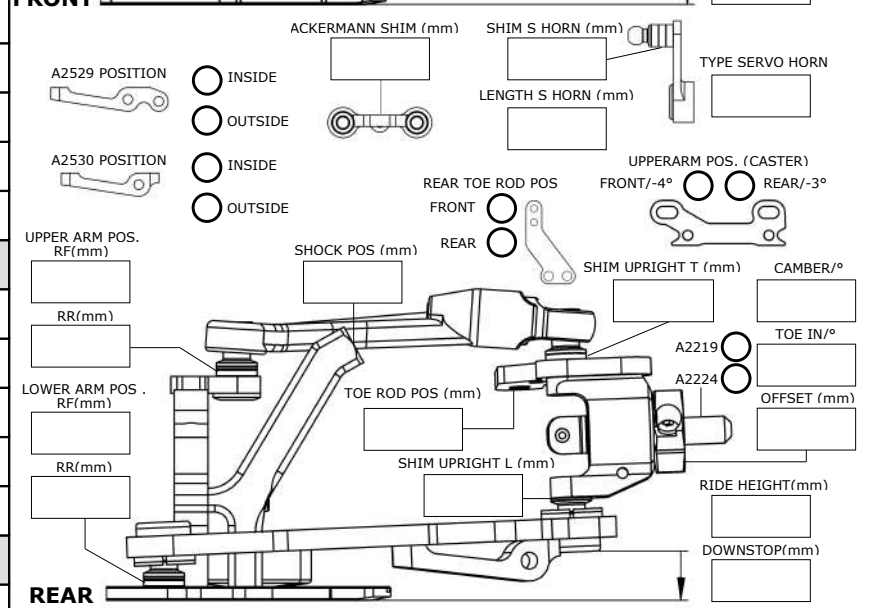
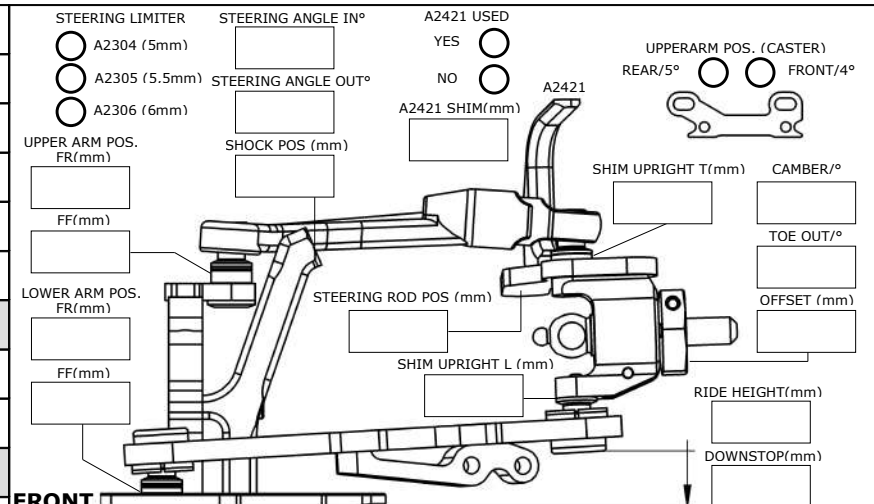

REMARKS