

DRIVER		
DATE		
TRACK	Carpet <input type="radio"/> Asphalt <input type="radio"/>	
TRACTION	<input type="radio"/> LOW <input type="radio"/> MEDIUM <input type="radio"/> HIGH	
LAYOUT	<input type="radio"/> SLOW <input type="radio"/> MIXED <input type="radio"/> FAST	
TEMP °C	AIR	TRACK
ELECTRONICS		
ESC	ESC SET	MOTOR
SERVO	RECEIVER	BATTERY
TIRES		
BRAND		
TYPE		
ADDITIVE		
WARMER °C	FRONT	REAR
TIME(min)	FRONT	REAR
SHOCK ABSORBERS		
PISTON	FRONT	REAR
SHOCK CASE		
OIL		
SPRING		
LENGTH		
ANTI ROLL BAR DIAMETER FRONT/REAR		
FRONT		REAR
REAR DIFFERENTIAL		
DIFF OIL CST (1,6g oil qty.)		
GEAR RATIO (T)Spur/(T)Pinion*1,9=Ratio		
PINION		SPUR
AERODYNAMIC SETTINGS		
BODY TYPE		
WING TYPE		
WING POS	(mm)	
BODY POSITION (see picture below)	(mm) \leftrightarrow horizontal	
FRONT BODY HEIGHT & POSITION	REAR BODY POST A2407C	<input type="radio"/> REAR BODY POST A2416B <input type="radio"/>
(mm) vertical \updownarrow	(mm)	(mm)

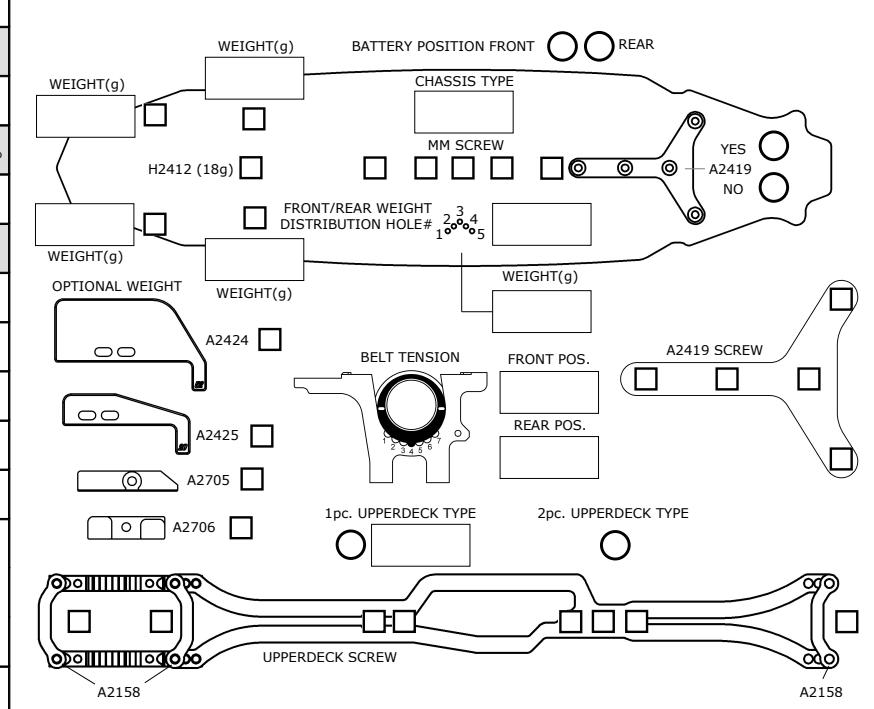
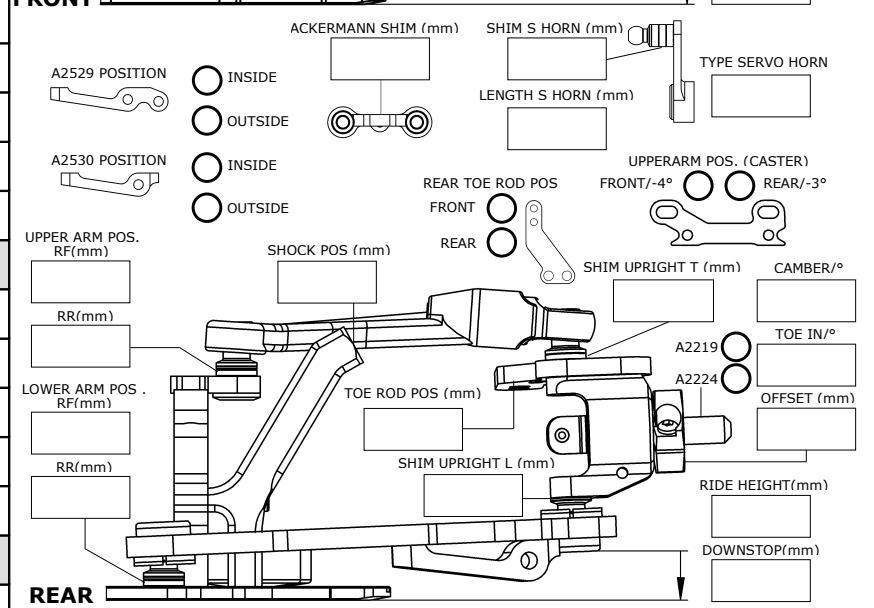
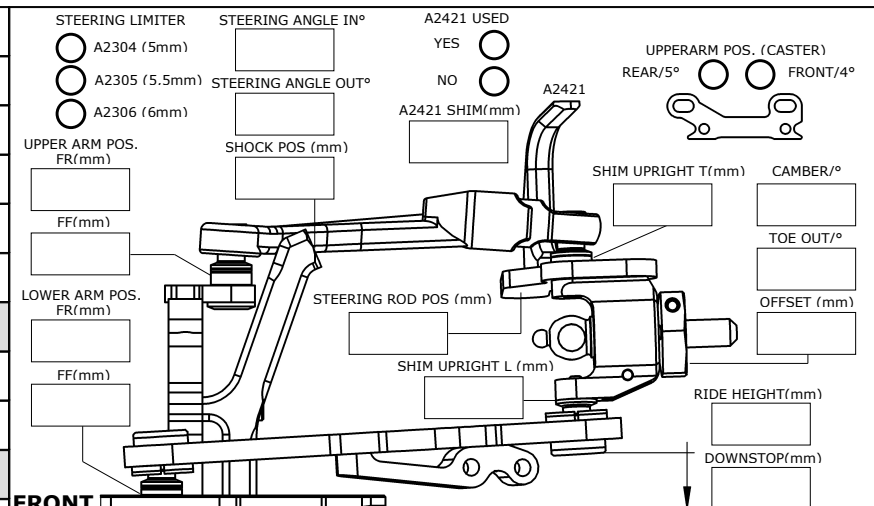

REMARKS