

MTC

1/10 ELECTRIC TOURING CAR

MUGEN SEIKI

●Items required for operation

- 2ch radio set for RC car (Transmitter, Receiver, Servo)
- Motor
- Pinion Gear
- Spur Gear
- ESC (Electric Speed Controller)
- Batteries for RC car
- Charger
- Body (190mm)
- Body paint tools
- Tires / Wheels / Inserts

●Tools required

- Hexagon Wrenches (1.5mm / 2mm / 2.5mm / 3mm)
- Box Wrench (7mm)
- Needle Nose Pliers
- Wire Cutters
- Sharp Hobby Knife
- Scissors
- Vernier Calipers
- Solder / Soldering Iron
- Instant Glue
- Turnbuckle wrench

●Neutral setting of transmitter

- * Before setting, read the instructions attached to the transmitter and ESC.
1. Turn on the transmitter.
 2. Set trims of transmitter.
 3. Set throttle side of transmitter according to the instruction manual ESC.
 4. Turn on the ESC according to the instruction manual and set the default.
 5. Check that the servos move properly in accordance with the control from transmitter.
 6. Turn off the ESC.
 7. Turn off the transmitter.

●キット以外に必要なもの

- RCカー用プロポ (送信機、受信機、サーボ)
- モーター
- ピニオンギヤ
- スパーギヤ
- スピードコントローラー
- 車体用バッテリー
- 充電器
- ボディ (190mm)
- ボディ塗装用の塗料
- タイヤ / ホイール / インナーフォーム

●キット制作に便利な工具類

- 六角レンチ (1.5mm / 2mm / 2.5mm / 3mm)
- ボックスレンチ (7mm)
- ラジオペンチ
- ニッパー
- カッターナイフ
- ハサミ
- ノギス
- ハンダ&ハンダごて
- 瞬間接着剤
- ターンバックルレンチ





























●プロポのニュートラル設定

- *使用するプロポ、スピードコントローラーに付属する取扱説明書をよく読み、事前に使用方法を理解しておいて下さい。
1. 送信機のスイッチをONにします。
 2. 送信機のトリムをセンターに合わせます。
 3. スピードコントローラーの説明書に従って、送信機のスロットル側の設定を行います。
 4. 説明書に従って、スピードコントローラーのスイッチをONにし、初期設定を行います。
 5. 送信機のハンドル / スティックを動かしてサーボが正常に動くか確認します。
 6. スピードコントローラーのスイッチをOFFにします。
 7. 送信機のスイッチをOFFにします。

Screw Chart

These are the actual sizes of the screws included with this kit.

使用ビス類一覧

 SiG2x3	 SiG3x10	 SJG2x6	 SJG3x6	 SJG3x14 2pcs.	 SG2x10	 SK3x3	 SK3x10
 SiG2x6	 SiG3x12	 SJG2x8	 SJG3x8	 SJG3x16 2pcs.	 SG3x8	 SK3x5	 SK3x12
 SiG3x5	 SiG3x14	 SJG2x10	 SJG3x10		 OE2.3	 SK3x6	 OW3x5x0.2
 SiG3x8		 SJG3x5	 SJG3x12			 SK3x8	 OW3.5x7.5x0.2

Before you start to assemble the kit, please read the instruction manual to the end.
組立てに入る前に説明書を最後までよく見てから作業を始めて下さい。



Apply Super Joint Grease.
スーパージョイントグリスを塗る。

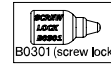

OPTION
Apply B0301 Lockfirm Liquid.
B0301ロックファームリキッドを塗る。

Positions to use optional titanium screw set A2815!

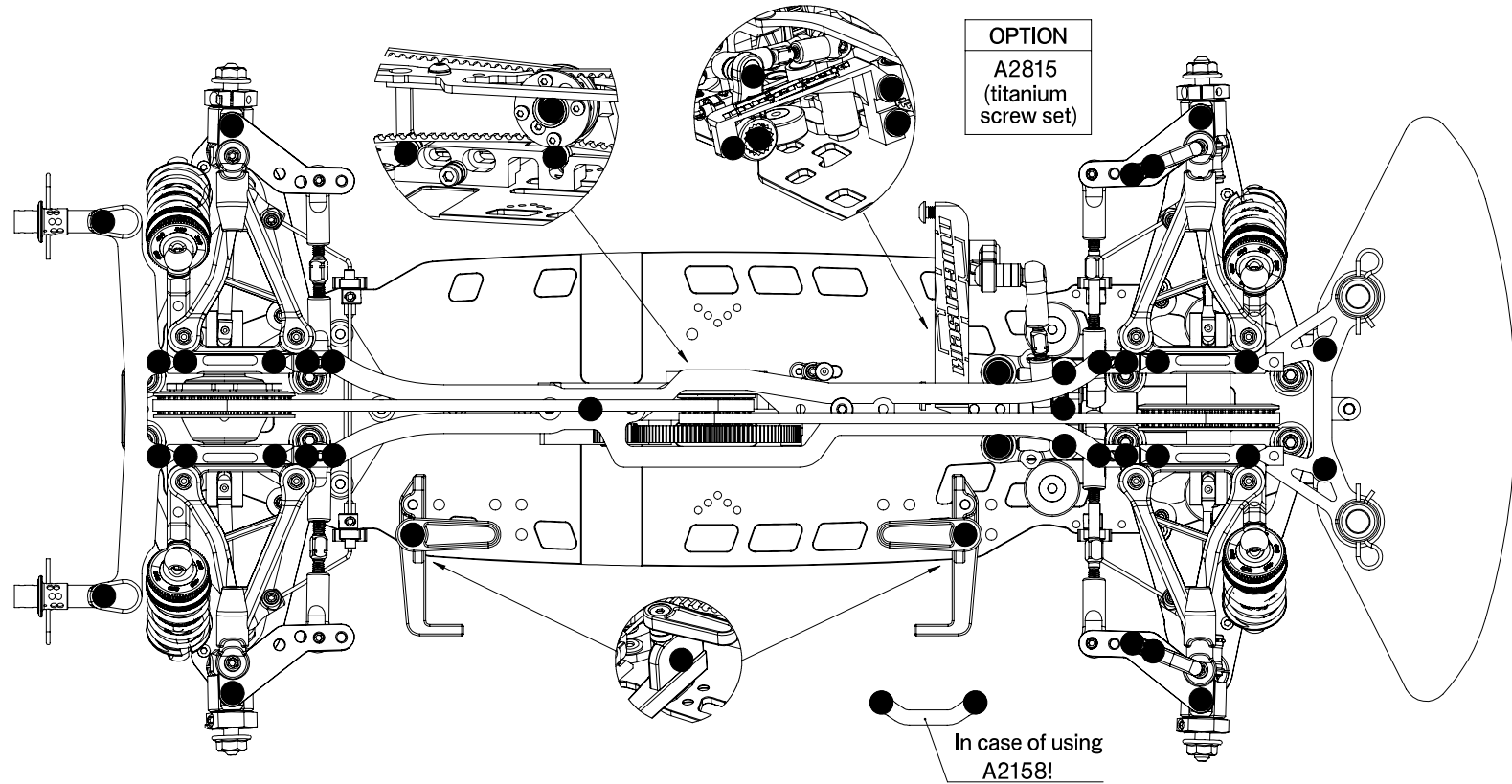

Chassis Preparation

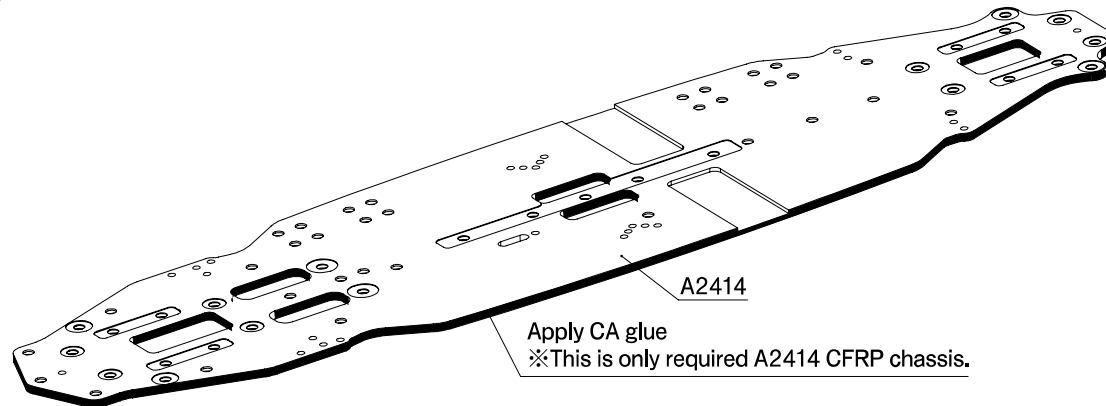

Setup sheet can be chosen by yourself from the sheets included, or from download area at www.mugenseiki.co.jp
 (if you choose the setup from download area, the parts included in the kit like springs, oil's might be different to the kit).

Explanation #1!

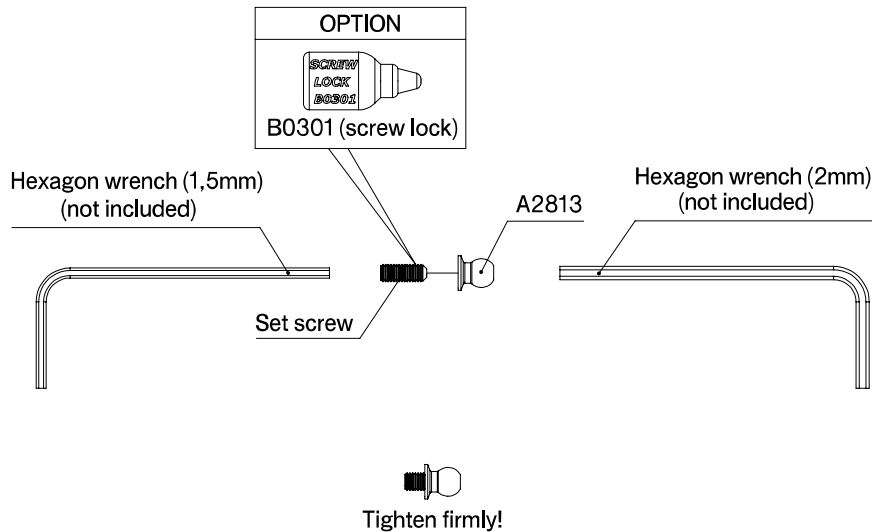

Explanation #2!

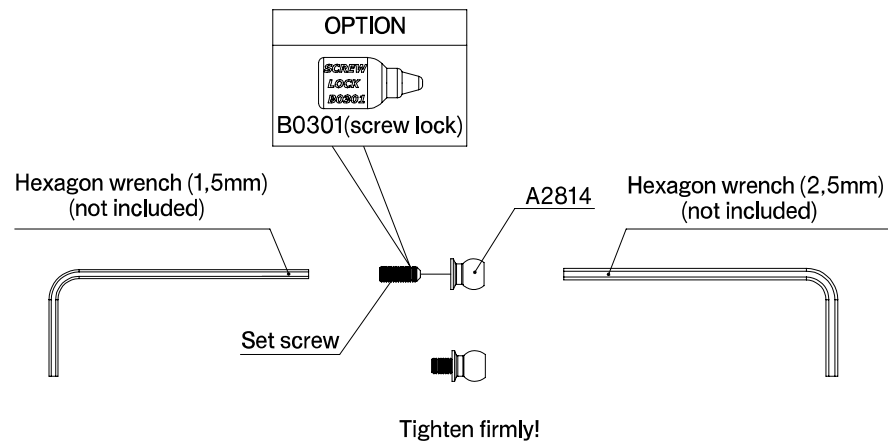

Explanation #3!

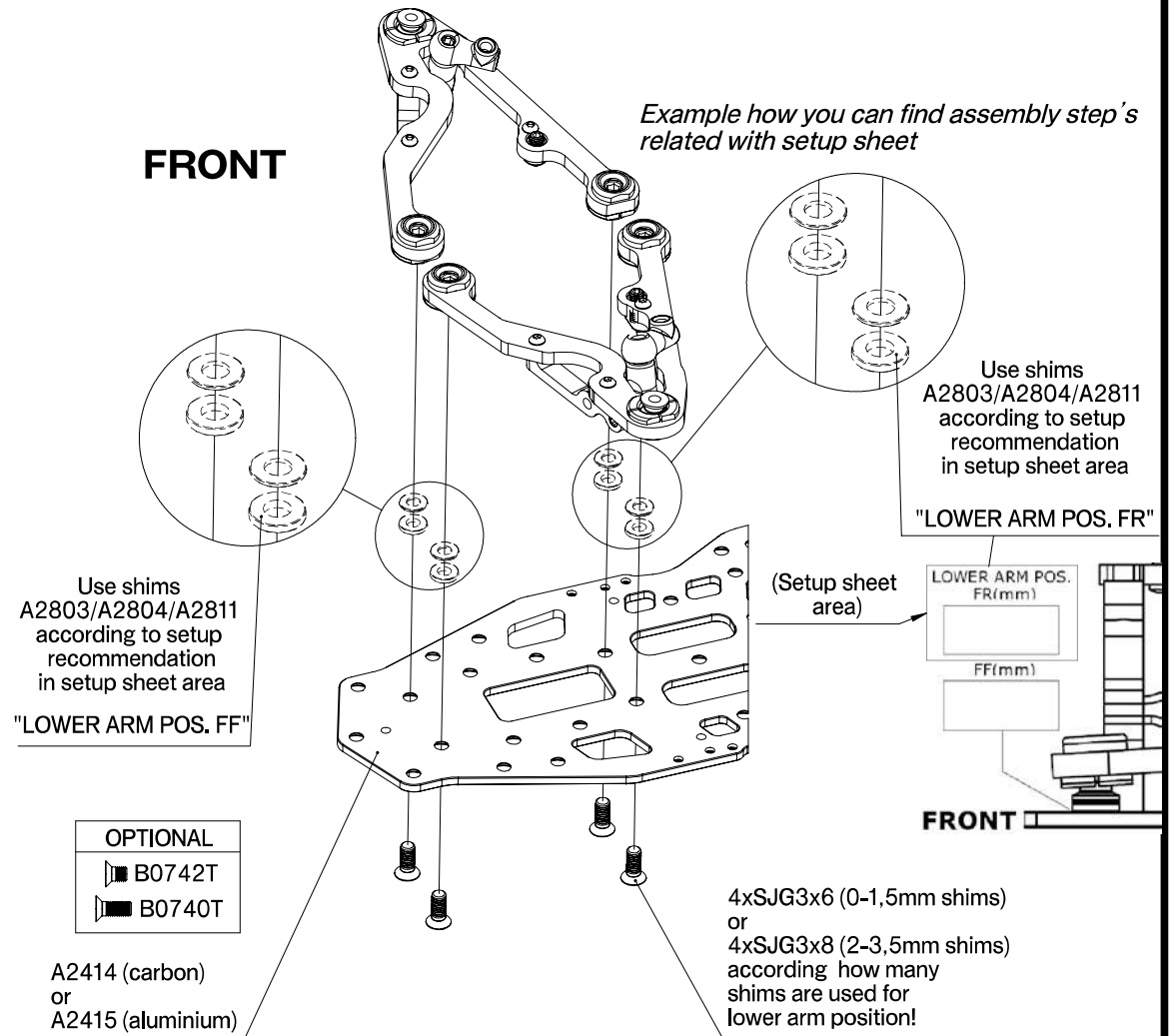

Step 1-1

Kit Bag-A1

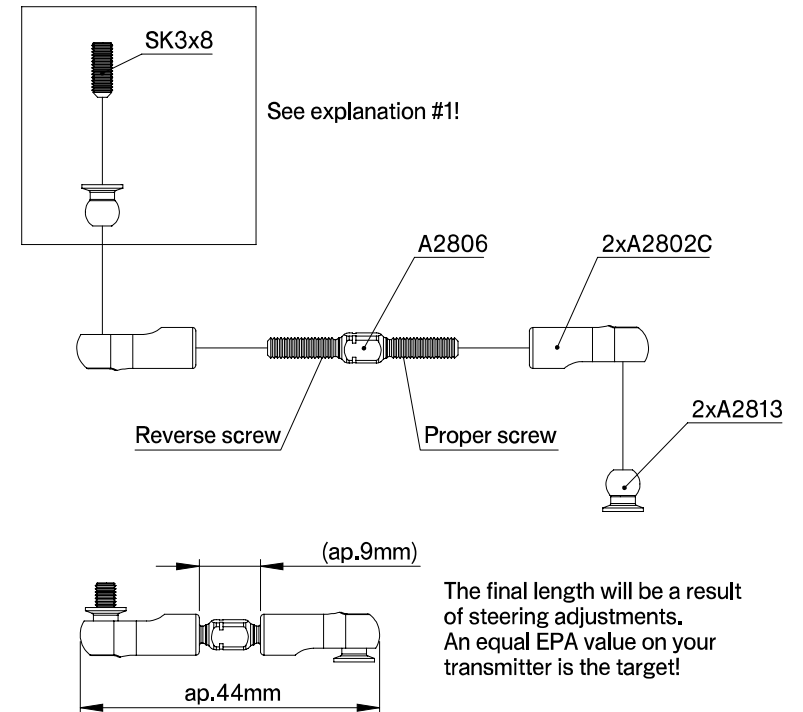
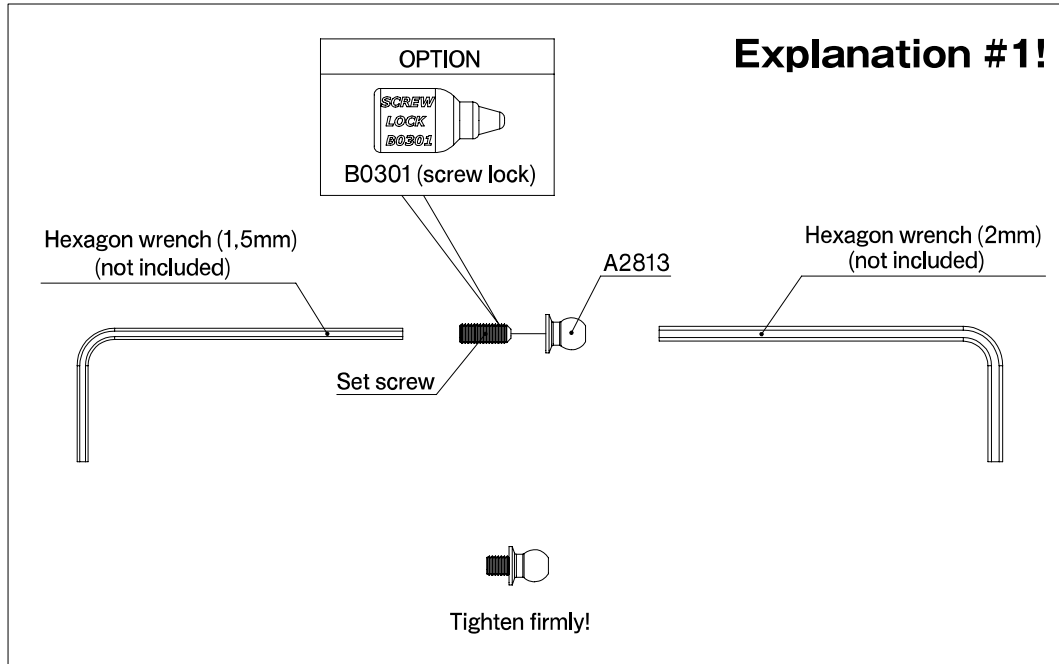

Step 1-2

Kit Bag-A1

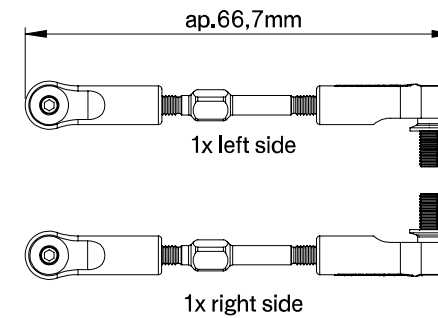
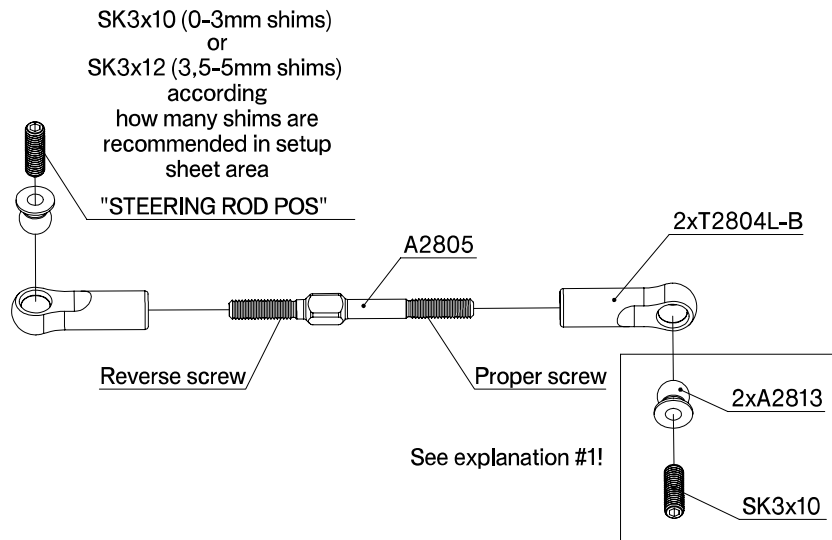

The final length will be a result of setup recommendation in setup sheet area

"TOE OUT" ° "

Step 1-3 Kit Bag-A1

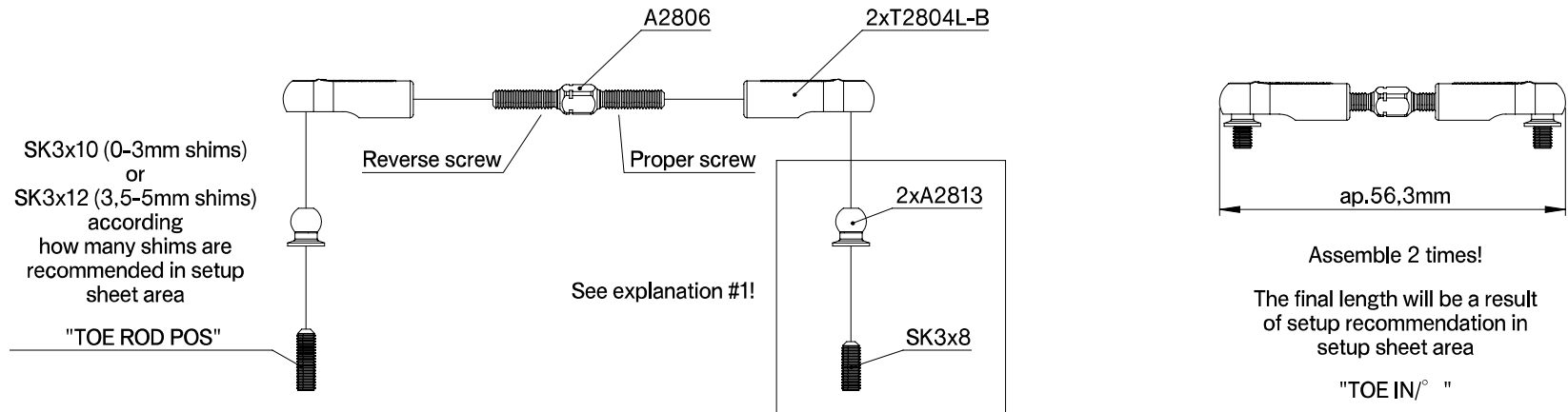

Step 2-1 Kit Bag-A1

Assemble 12 times!

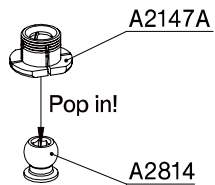

FRONT

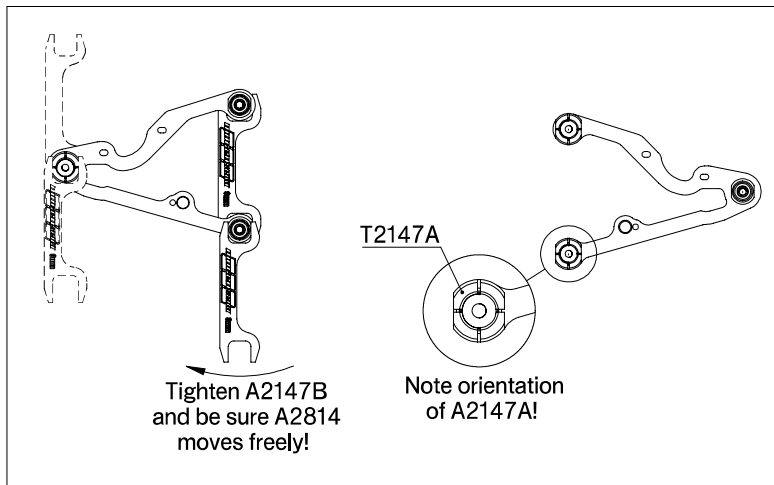
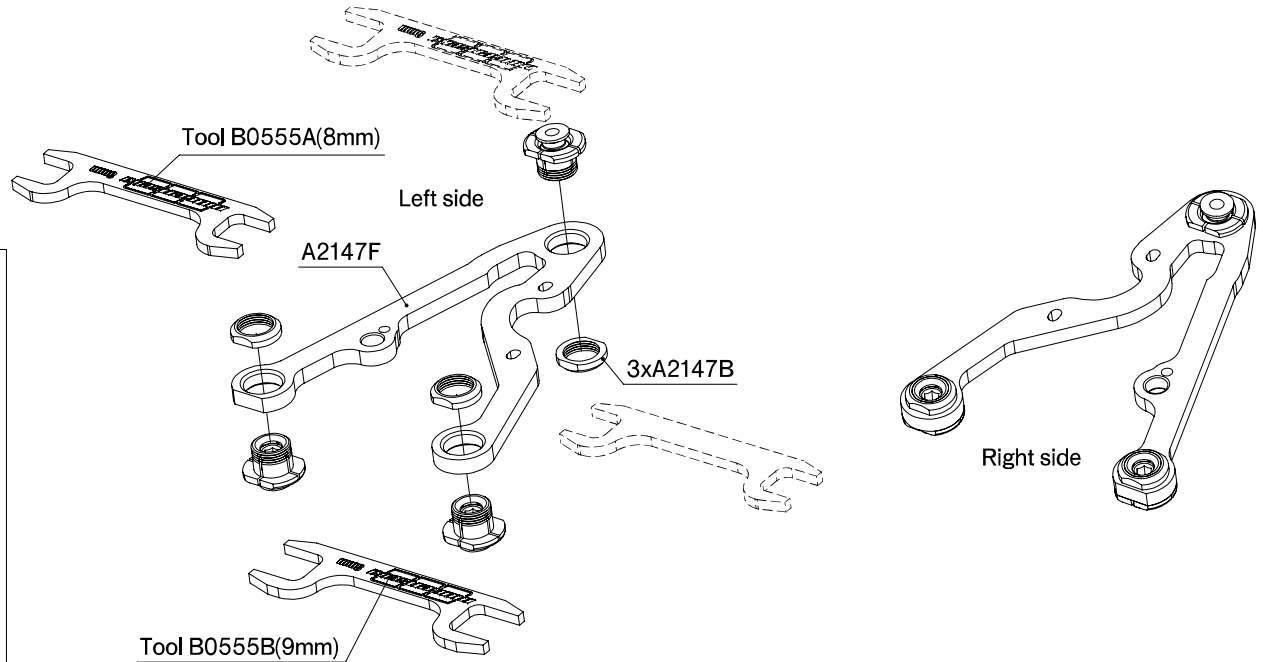

Step 2-2

Kit Bag-A1

FRONT

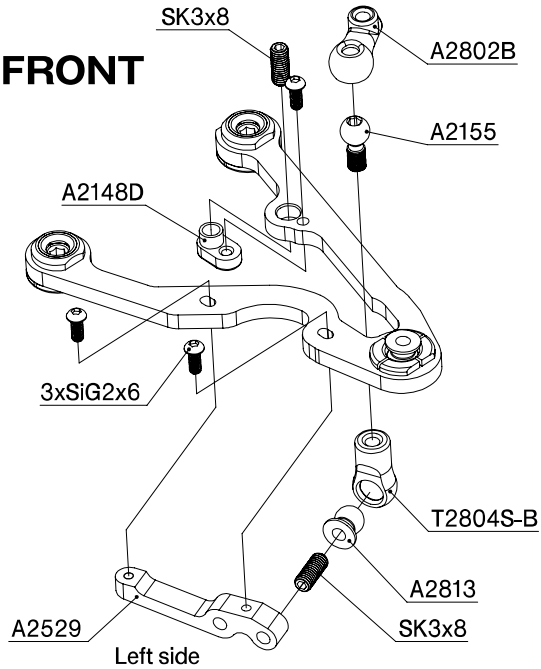

Please find the position of A2529 according to setup recommendation in setup sheet area
"A2529 POSITION"

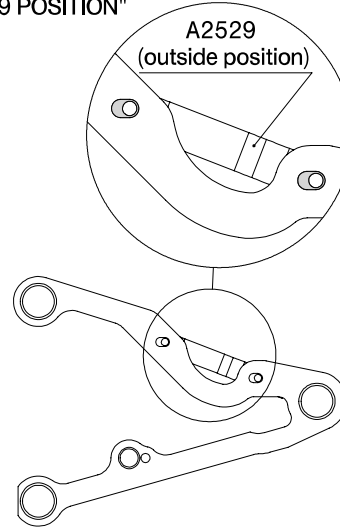
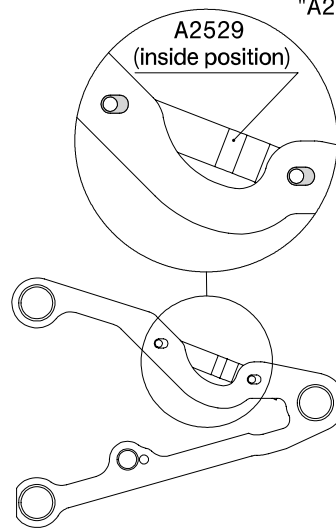

ARB ENDPLAY

Pre-adjust the ARB linkage to ap. 19,5mm for both sides!
Adjust the final endplay left/right equal, after having finished your final downstop setting!

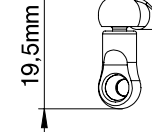

DOWNSTOP

Pre-adjust the downstop set screw to ap. 3mm for both sides!
Please find the final adjustment in your setup recommendation in setup sheet area
"DOWNSTOP"

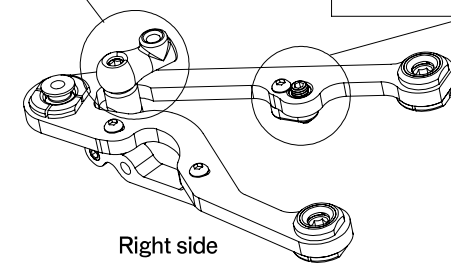
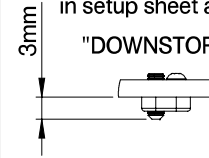

Step 2-3

Kit Bag-A1

REAR

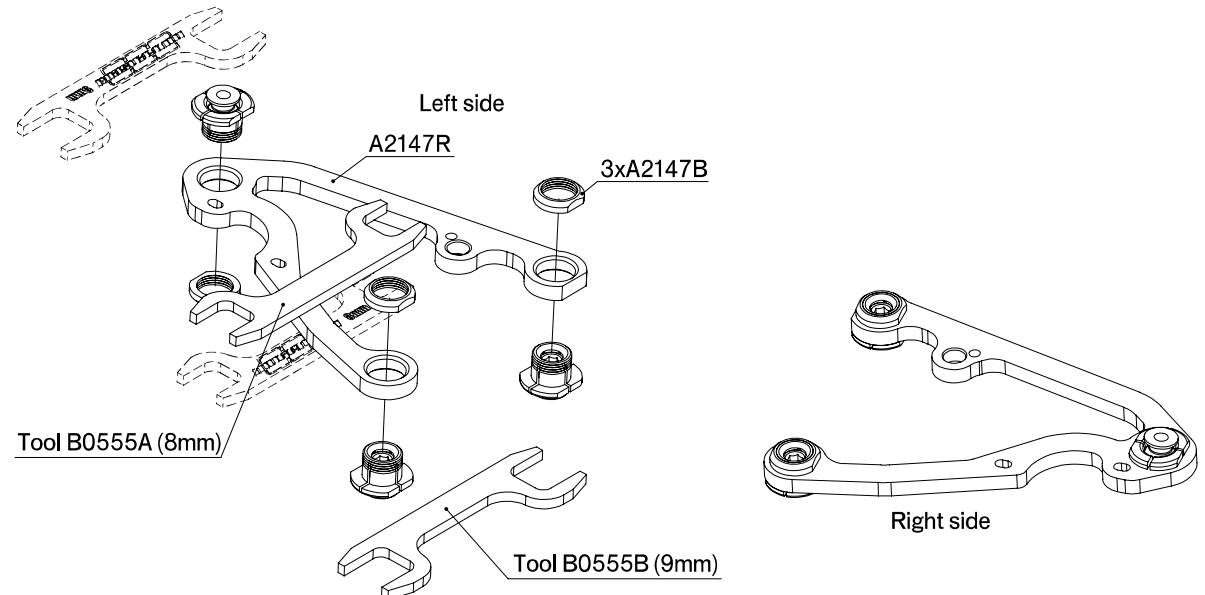
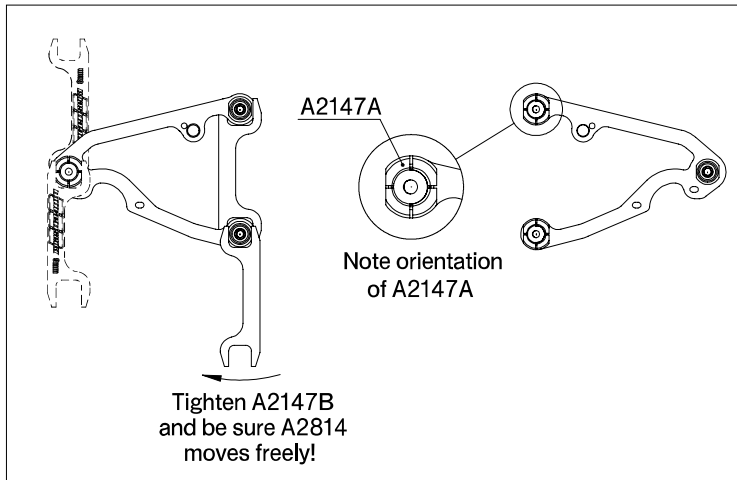

Step 2-4

Kit Bag-A 1

Please find the position of A2530 according to setup recommendation in setup sheet area

"A2530 POSITION"

REAR

Left side

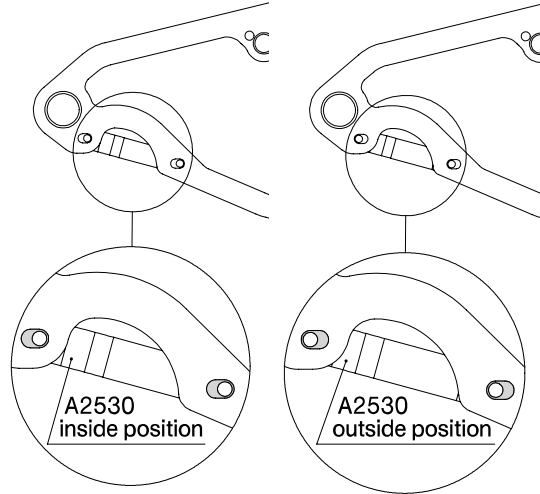
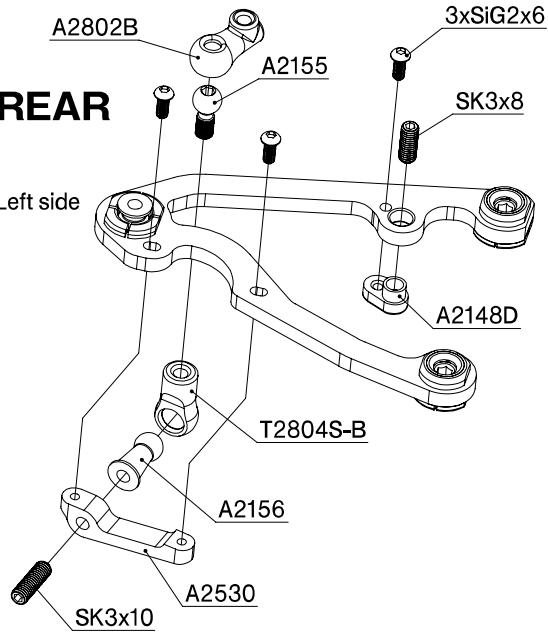

DOWNSTOP

Pre-adjust the downstop set screw to ap. 3mm for both sides!
Please find the final adjustment in your setup recommendation in setup sheet area

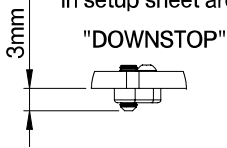

ARB ENDPLAY

Pre-adjust the ARB linkage to ap. 19.5mm for both sides!
Adjust the final endplay left/right equal, after having finished your final downstop setting!

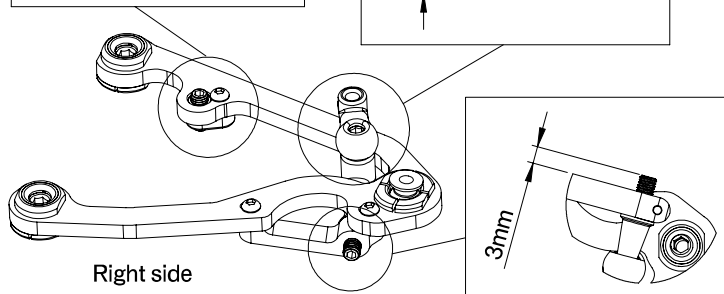
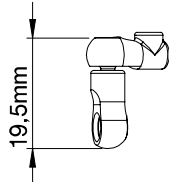

Right side

Step 3-1

Kit Bag-A 1

Explanation #3!

FRONT

Example how you can find assembly step's related with setup sheet

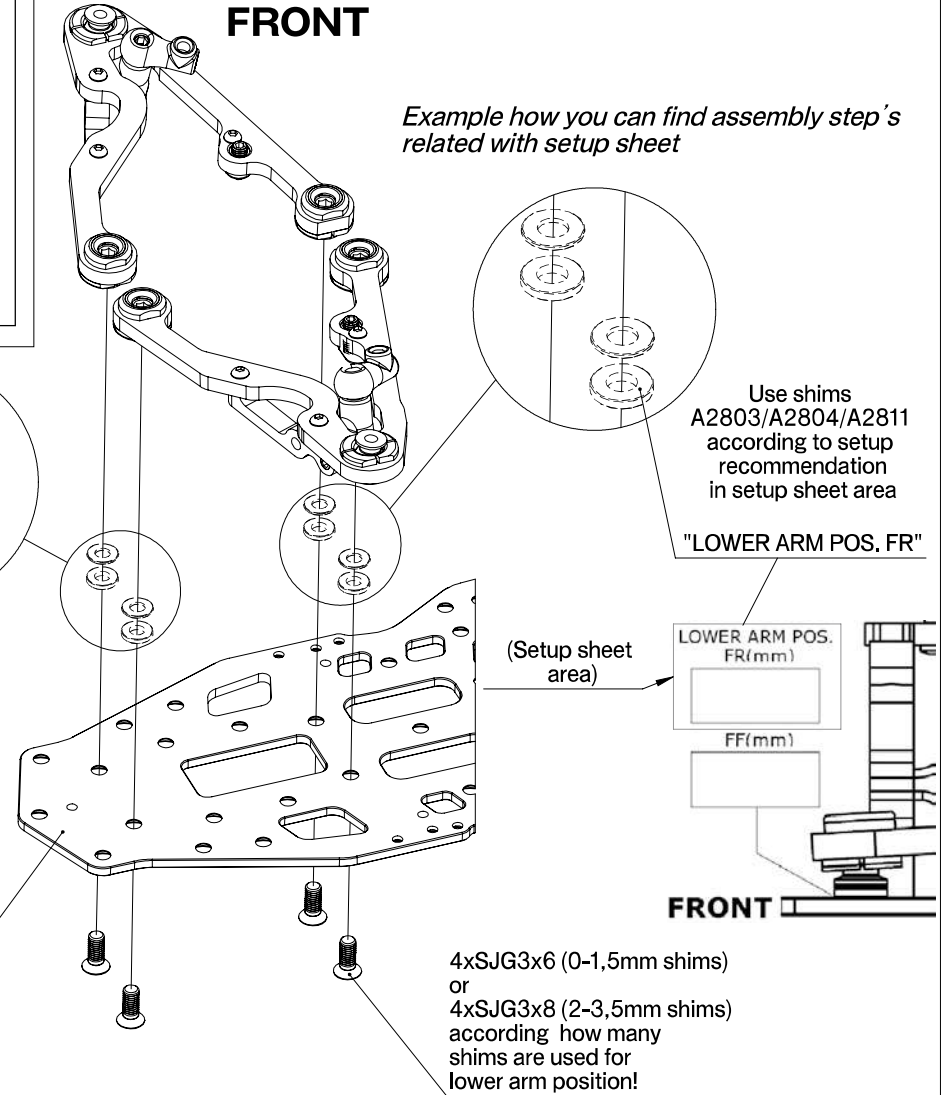

Use shims A2803/A2804/A2811 according to setup recommendation in setup sheet area

"LOWER ARM POS. FR"

(Setup sheet area)



FRONT

Use shims A2803/A2804/A2811 according to setup recommendation in setup sheet area

"LOWER ARM POS. FF"

OPTIONAL

B0742T

B0740T

A2414 (carbon)
or
A2415 (aluminium)

4xSJG3x6 (0-1,5mm shims)
or
4xSJG3x8 (2-3,5mm shims)
according to how many shims are used for lower arm position!

Step 3-2

Kit Bag-A1

REAR

Use shims
A2803/A2804/A2811
according to setup
recommendation
in setup sheet area

"LOWER ARM POS. RF"

Use shims
A2803/A2804/A2811
according to setup
recommendation
in setup sheet area

"LOWER ARM POS. RR"

4xSJG3x6 (0-1,5mm shims)
or
4xSJG3x8 (2-3,5mm shims)
according how many
shims are used for
lower arm position!

OPTIONAL

 B0742T

 B0740T

Step 3-3

Kit Bag-A1

REAR

Use A2419 according
to setup recommendation
in setup sheet area

"A2419"

with recommended screws
in setup sheet area

"A2419 SCREW"

5xT2157B

A2419

5xSJG3x5

OPTION

 B0753T

Step 3-4

Kit Bag-A1/B1

FRONT

Use H2412 according to setup recommendation in setup sheet area

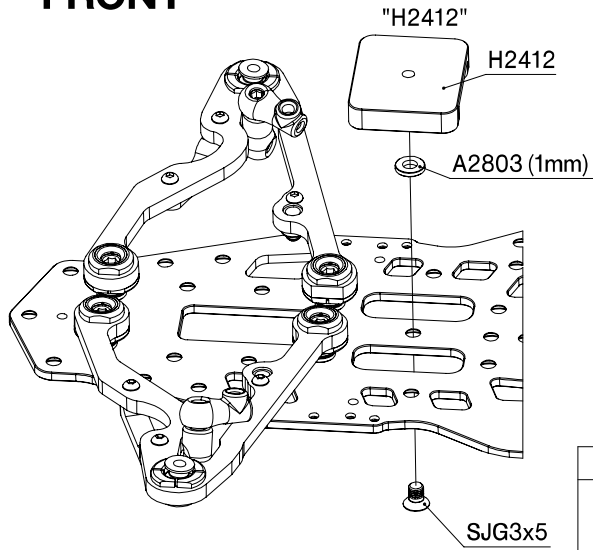

OPTION

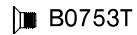

2xA2422
(2pcs. included)

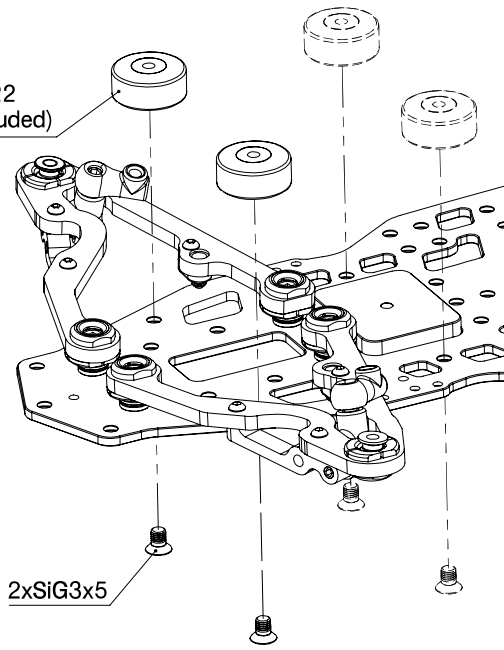

OPTION



A2422 (10g)
2pcs. included!

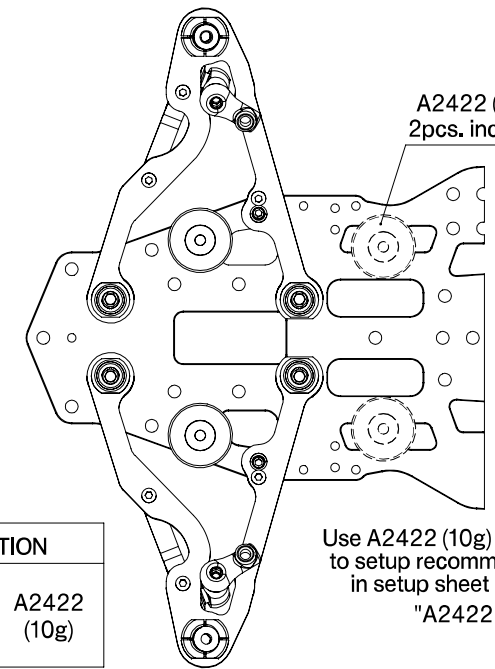

Use A2422 (10g) according to setup recommendation in setup sheet area "A2422"

Step 4-1

Kit Bag-B1

Assemble 2 times!

Rear toe rod

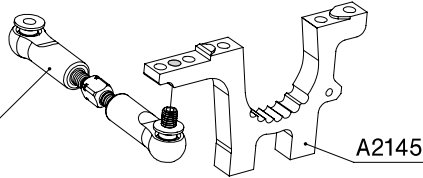

A2524F

A2524R

FRONT

2xSG2x10

2xA2524F

2xA2145

OPTION



6xSJG3x5

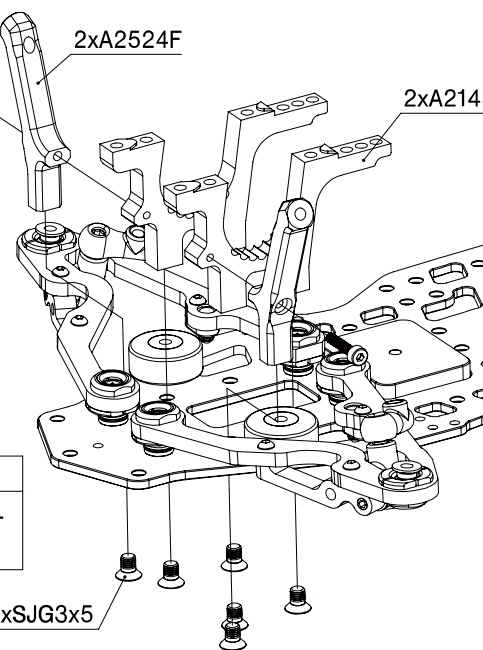

REAR

2xSG2x10

2xA2524R

OPTION

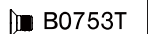

6xSJG3x5

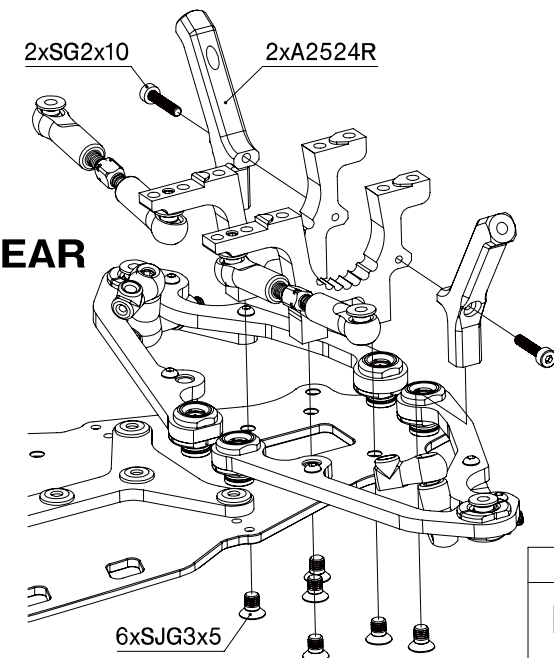

Step 5-1

Kit Bag-A2/B1

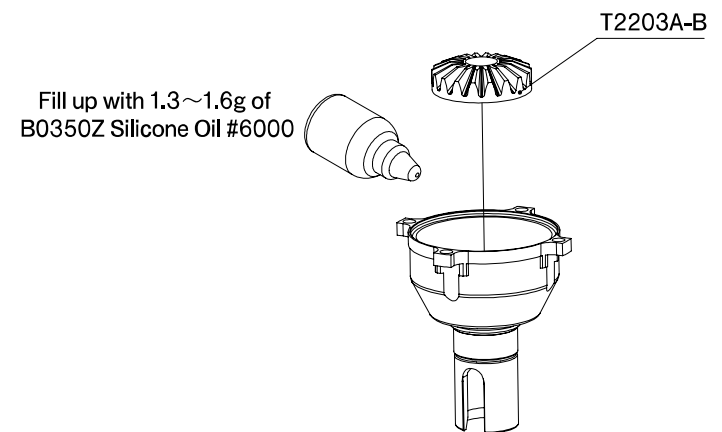
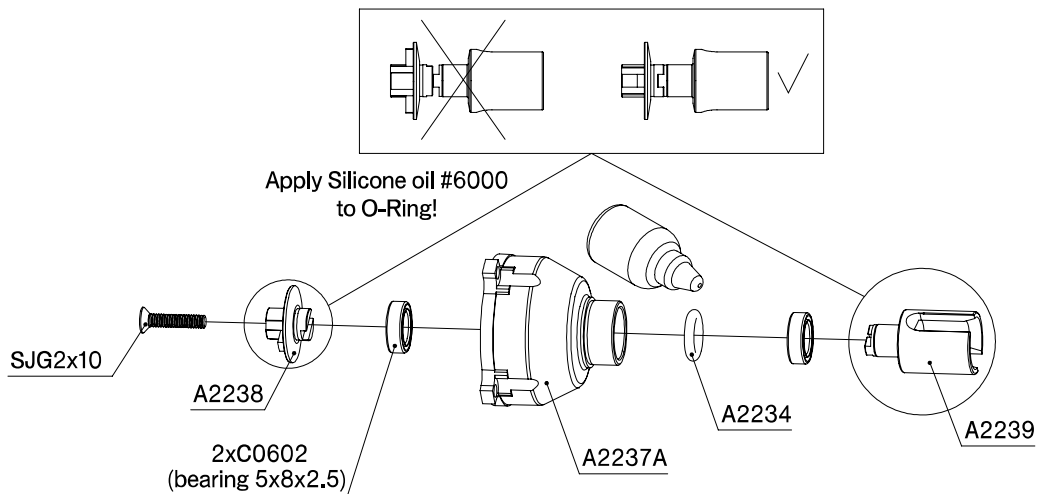
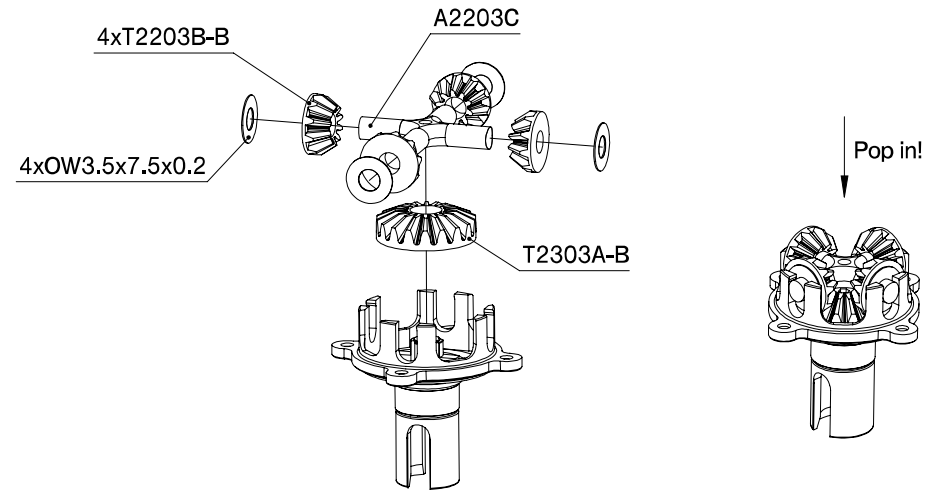
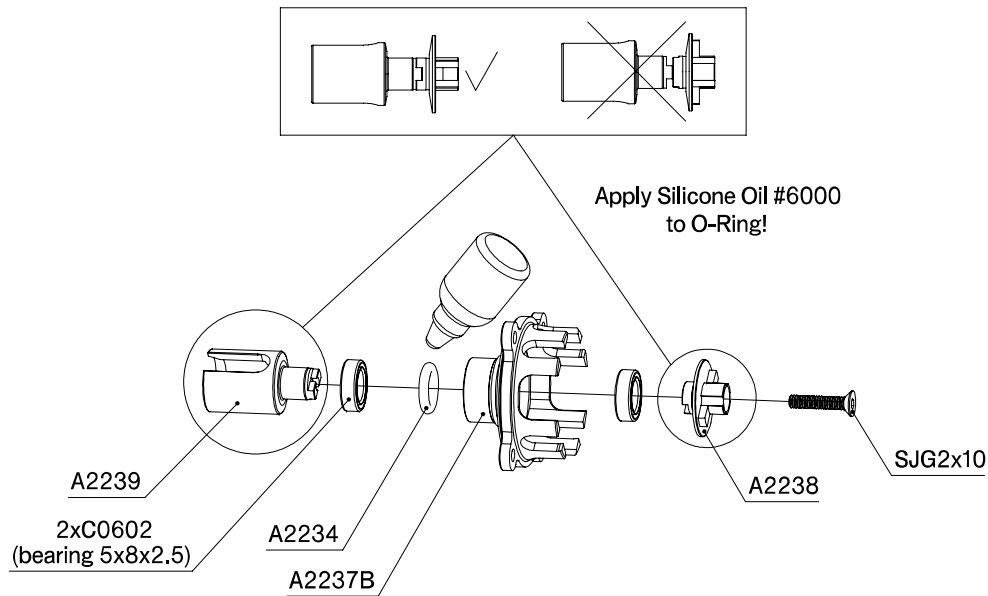

Step 5-2

Kit Bag-A2/B1

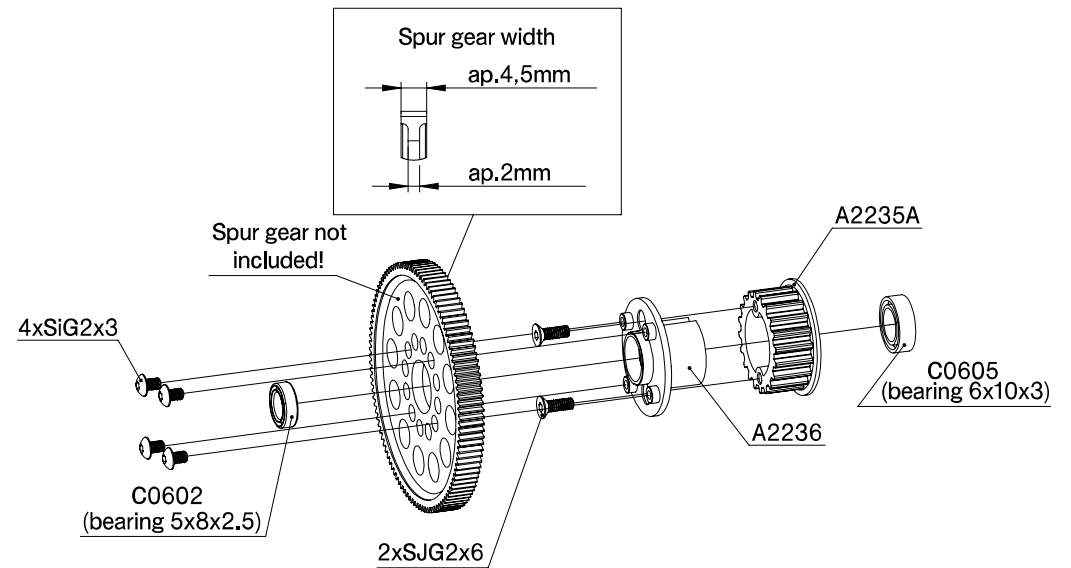
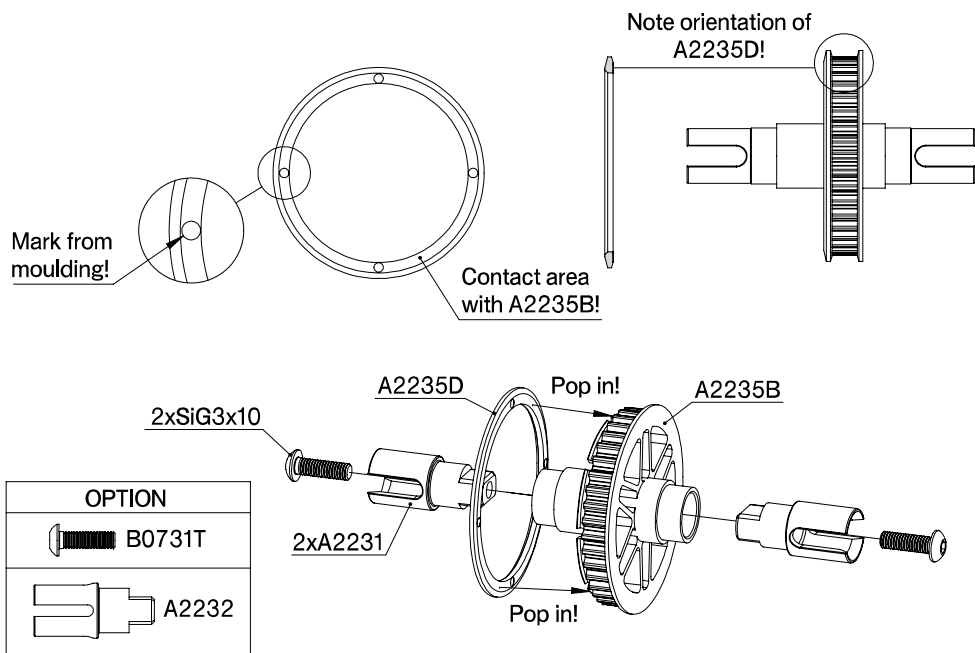
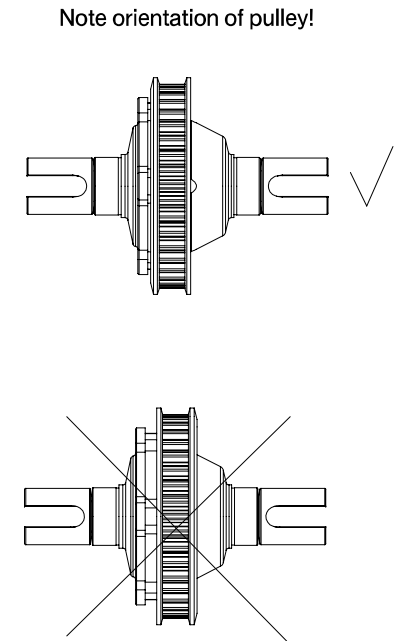
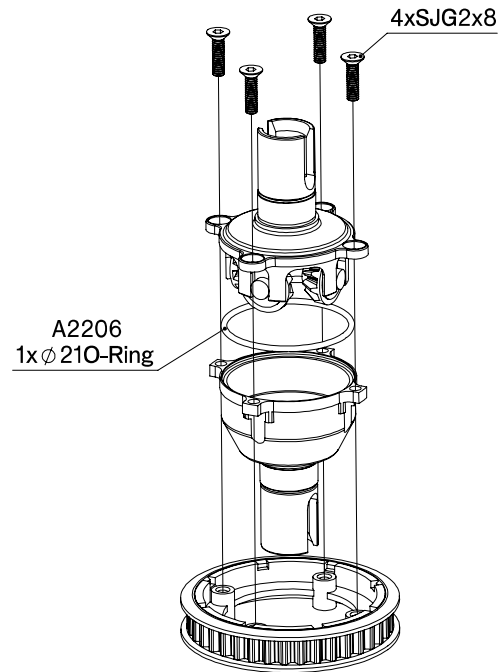
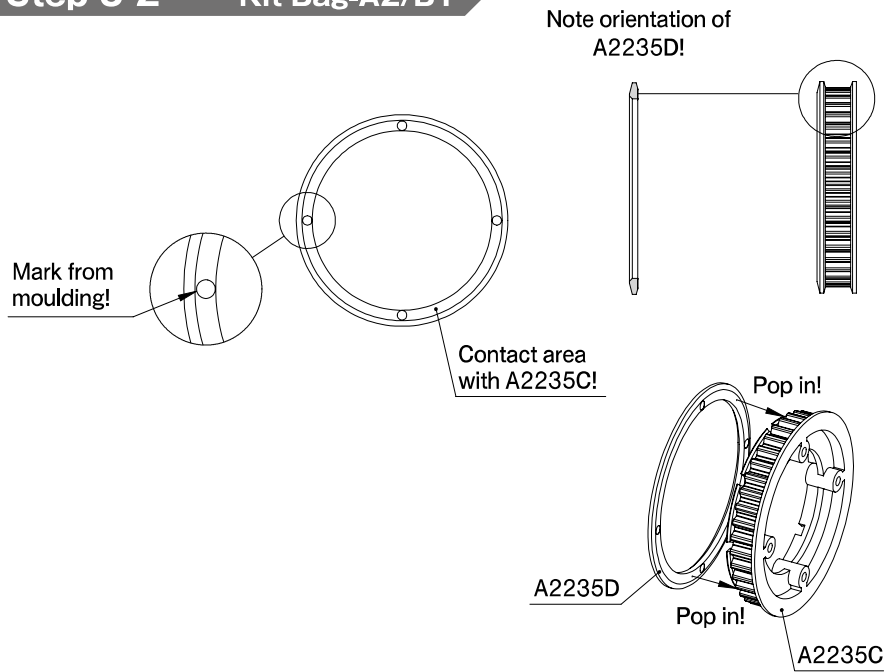

Step 6-1 Kit Bag-A2/C1/Upperdeck

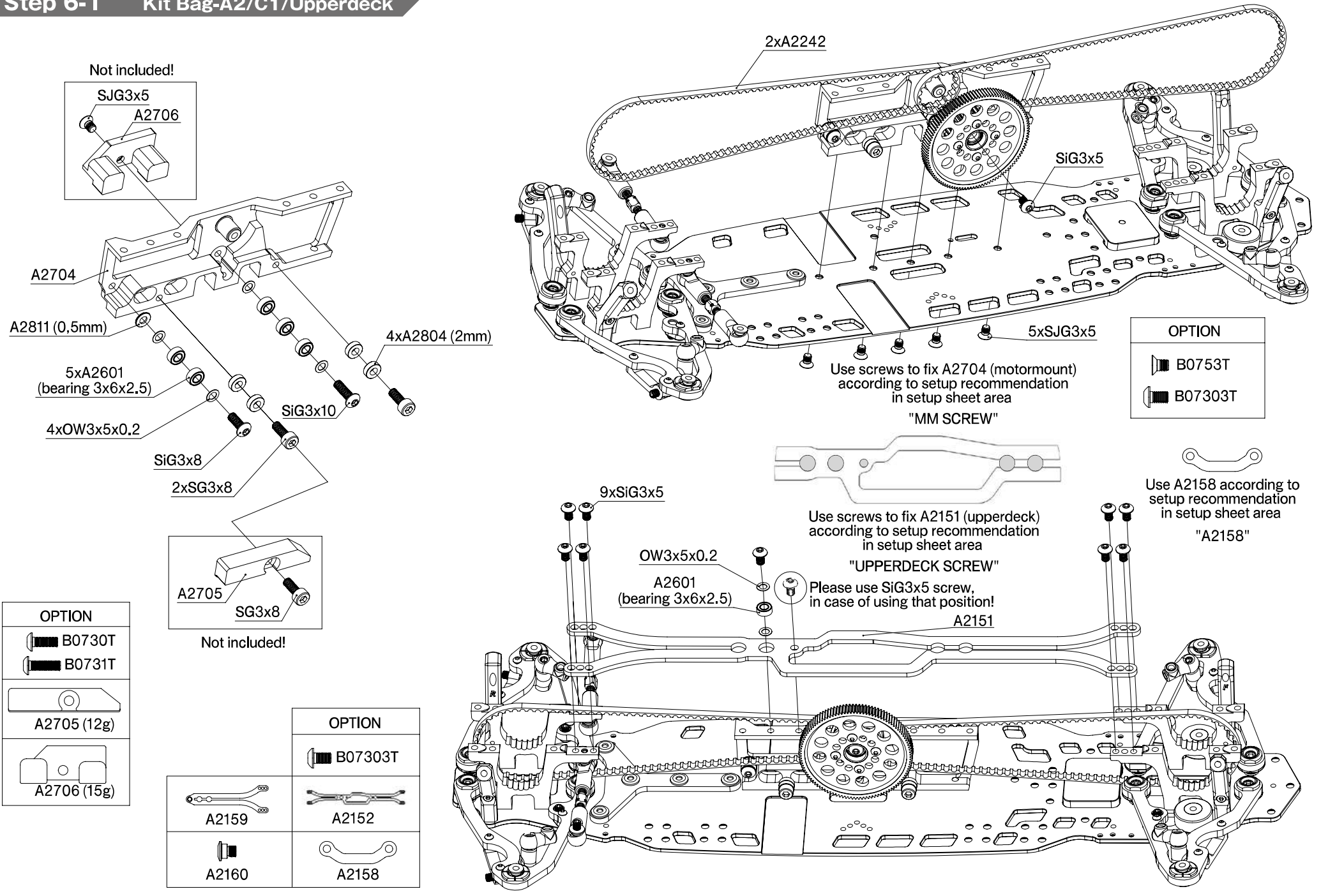

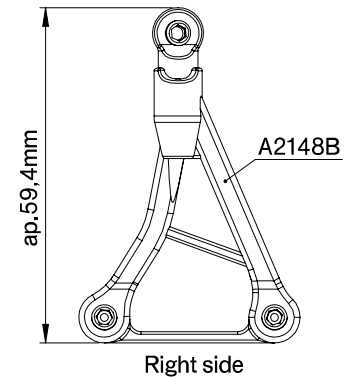
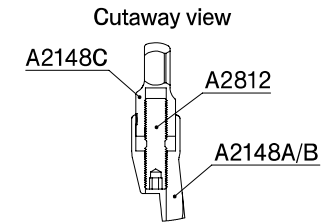
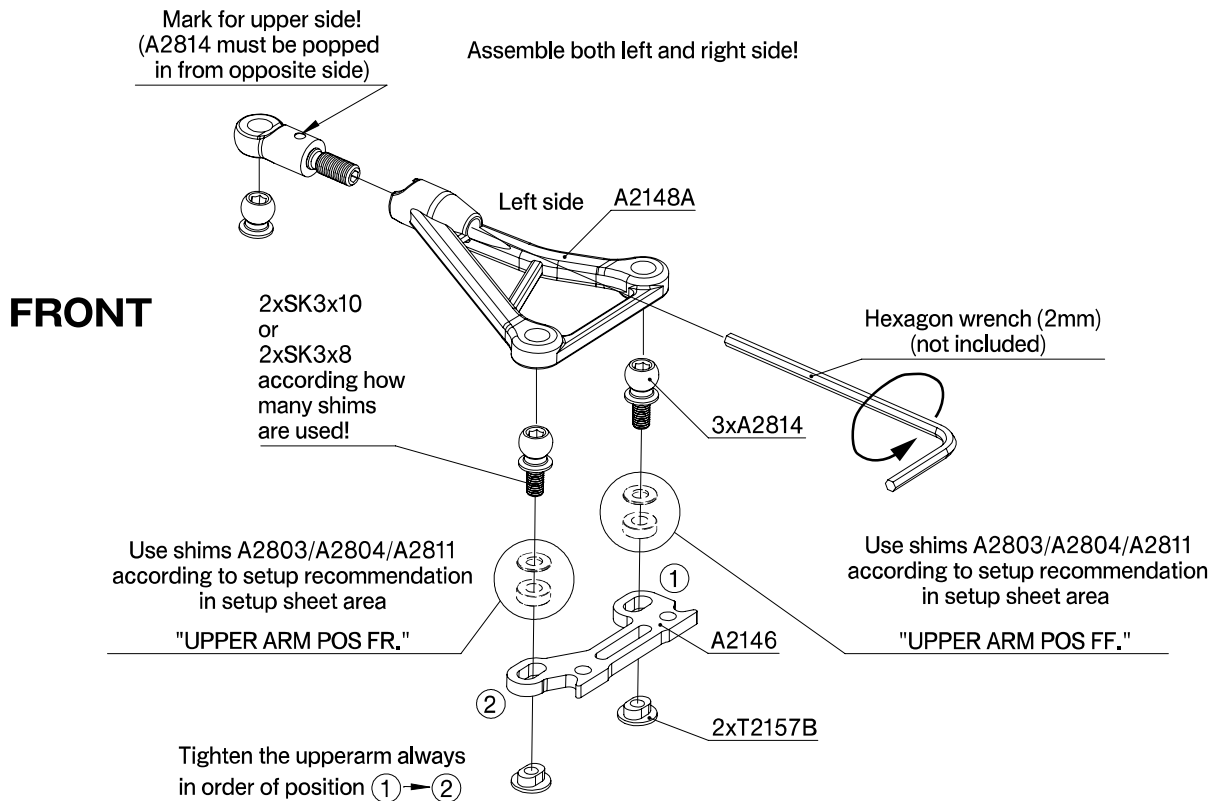
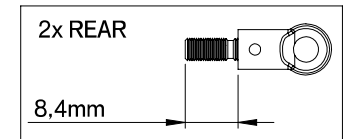
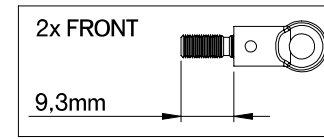
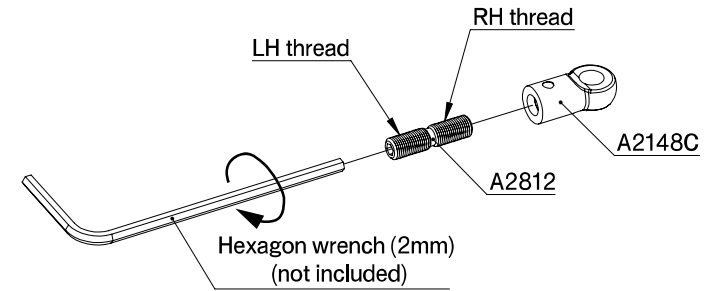
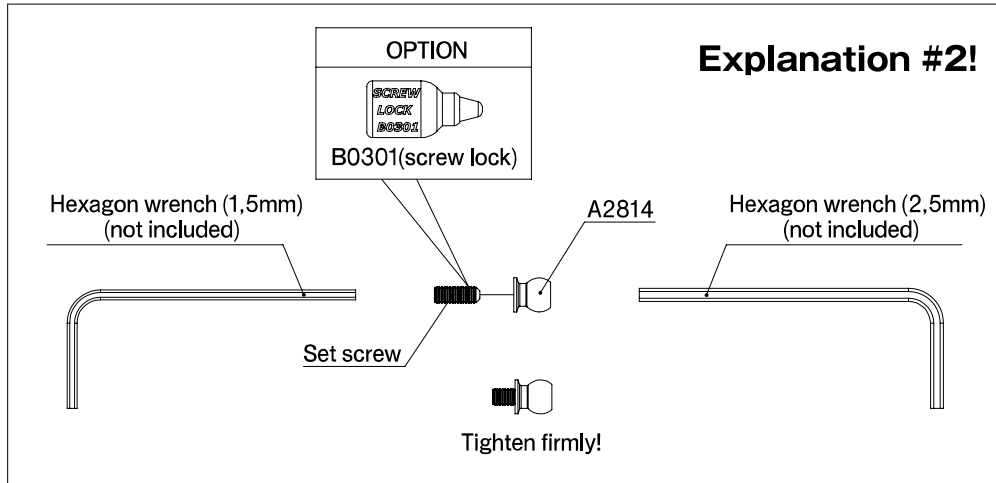

Upperarm position front 4°

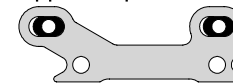

Use the position of Upperarm according to setup recommendation in setup sheet area

Upperarm position rear 5°

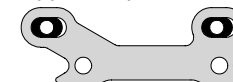

"UPPERARM POS. (CASTER)"

REAR

Mark for upper side!
(A2814 must be popped
in from opposite side)

Assemble both left and right side!

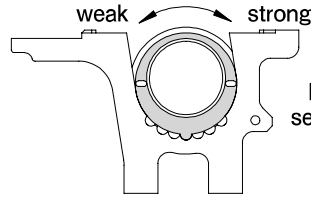

Find belt tension at
setup recommendation
in setup sheet area
"BELT TENSION"

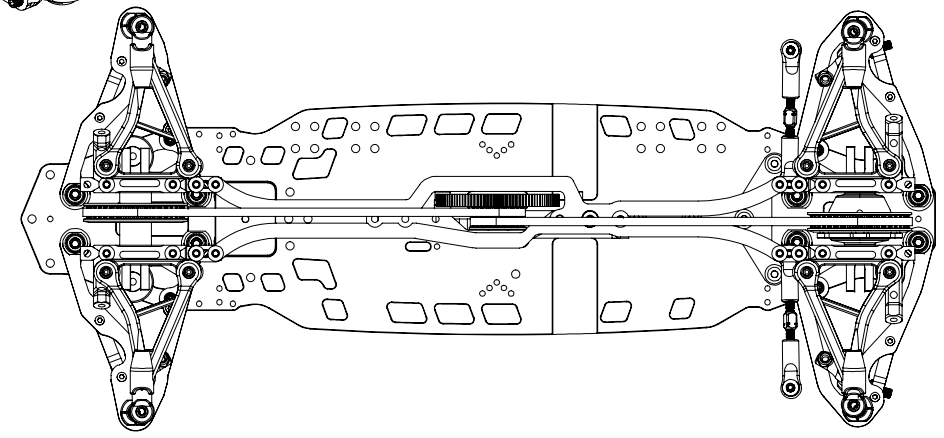
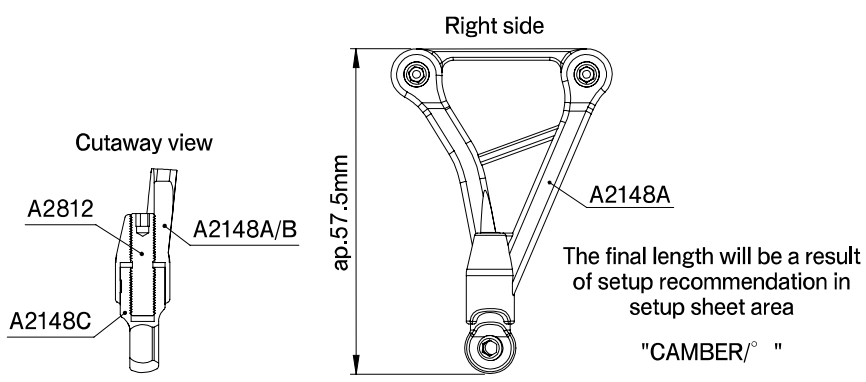
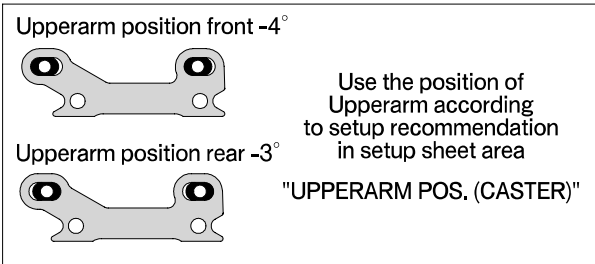
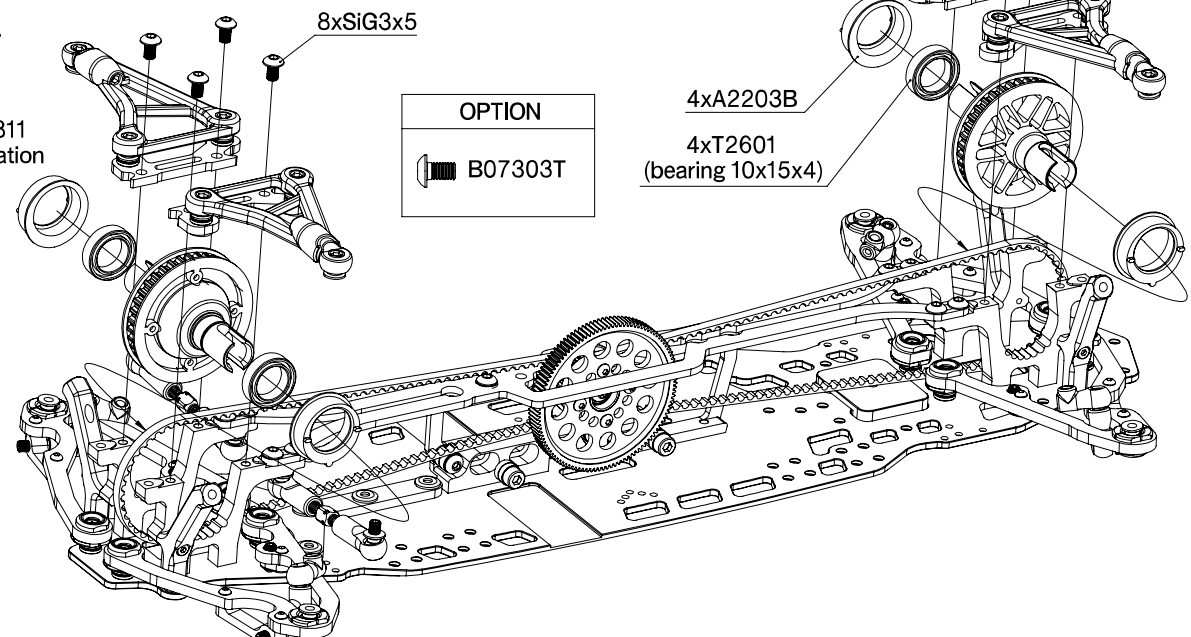
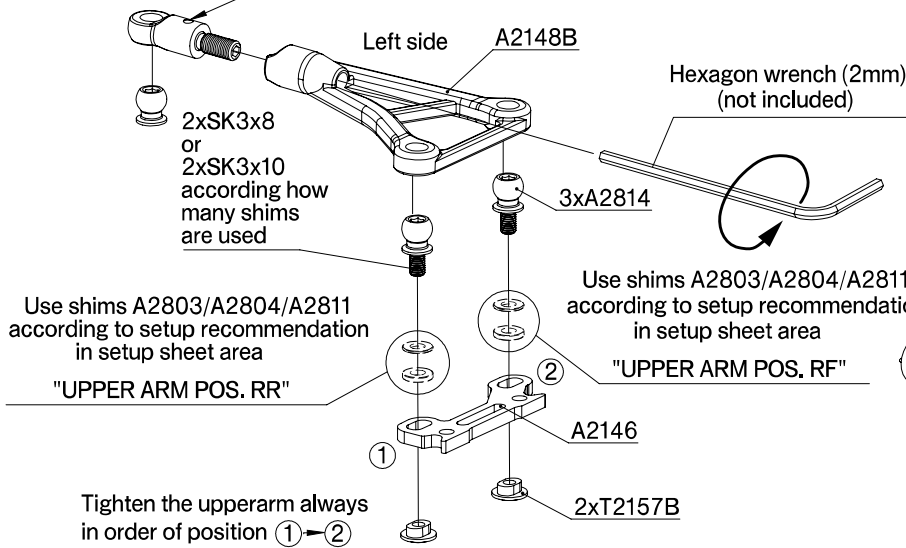

Step 8-1

Kit Bag-C1

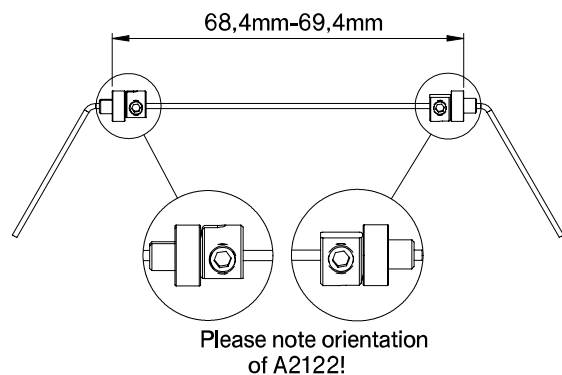
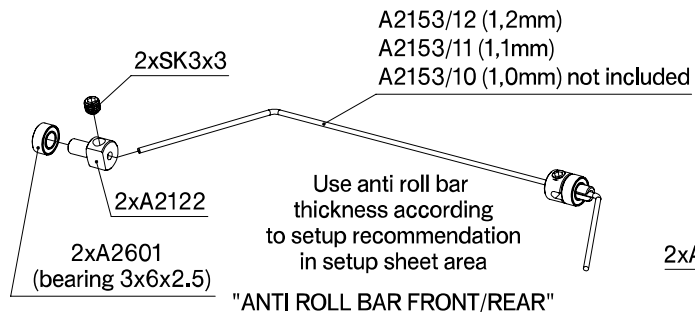

Be sure anti roll bar's moving freely!

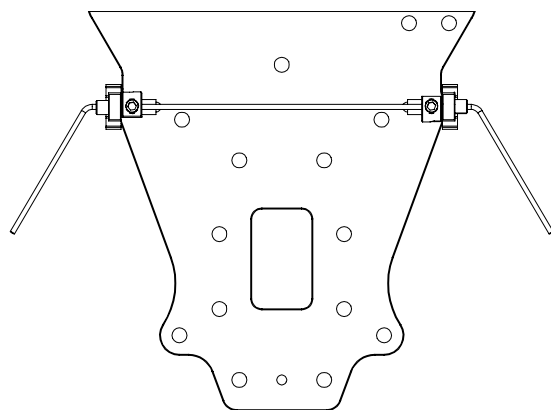

REAR

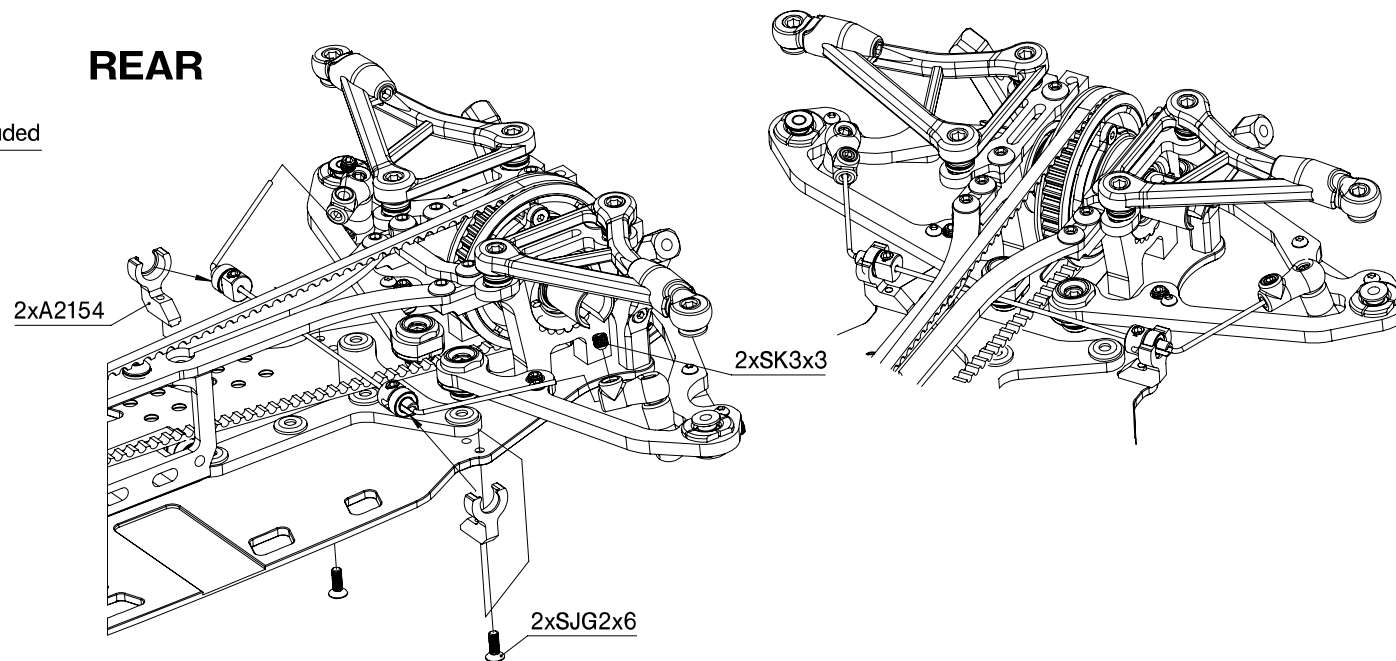

FRONT

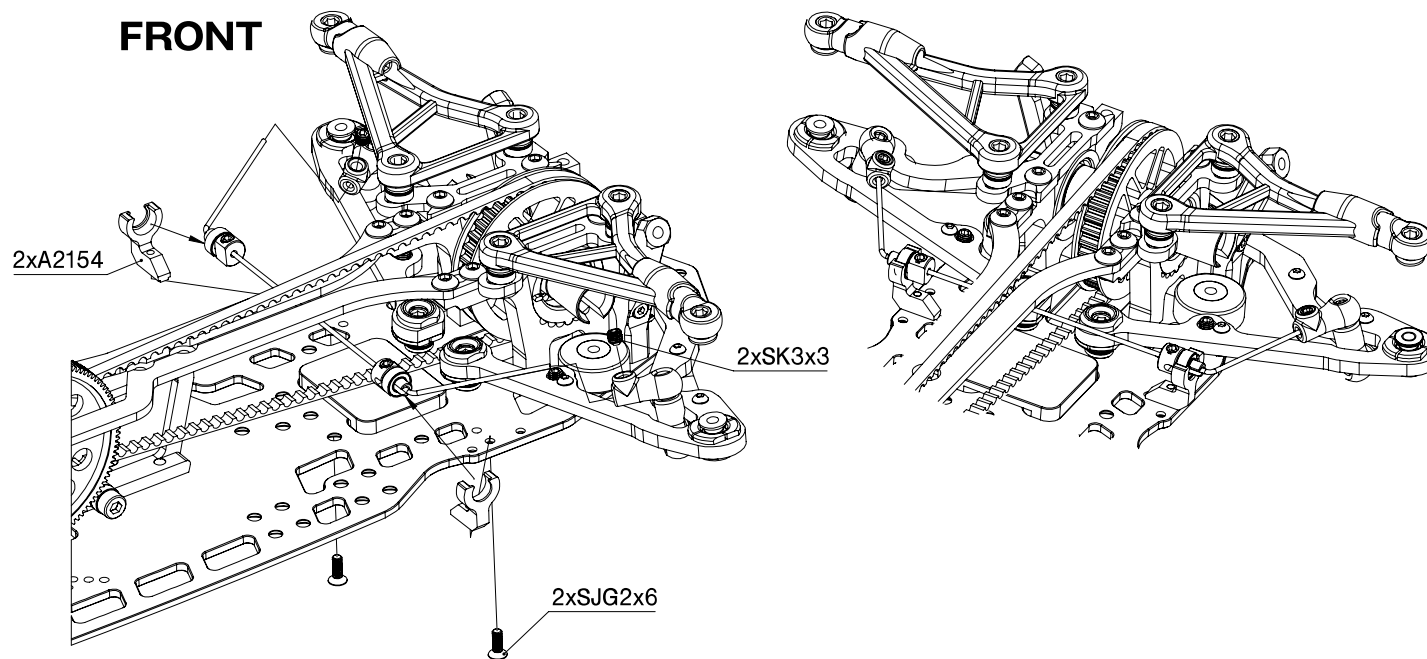

Step 9-1

Kit Bag-C1

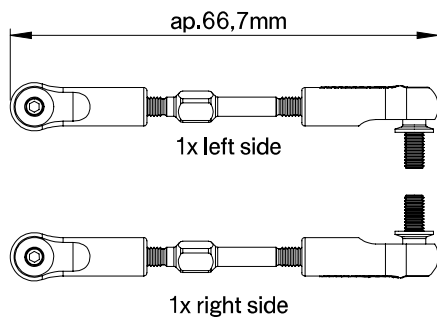

The final length will be a result of setup recommendation in setup sheet area

"TOE OUT/° "

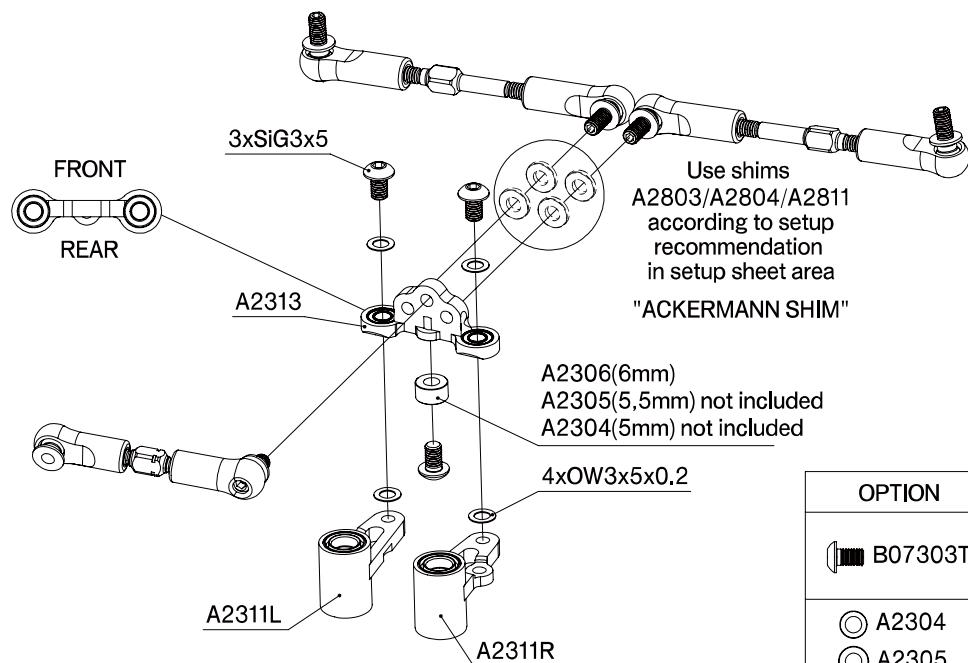

OPTION

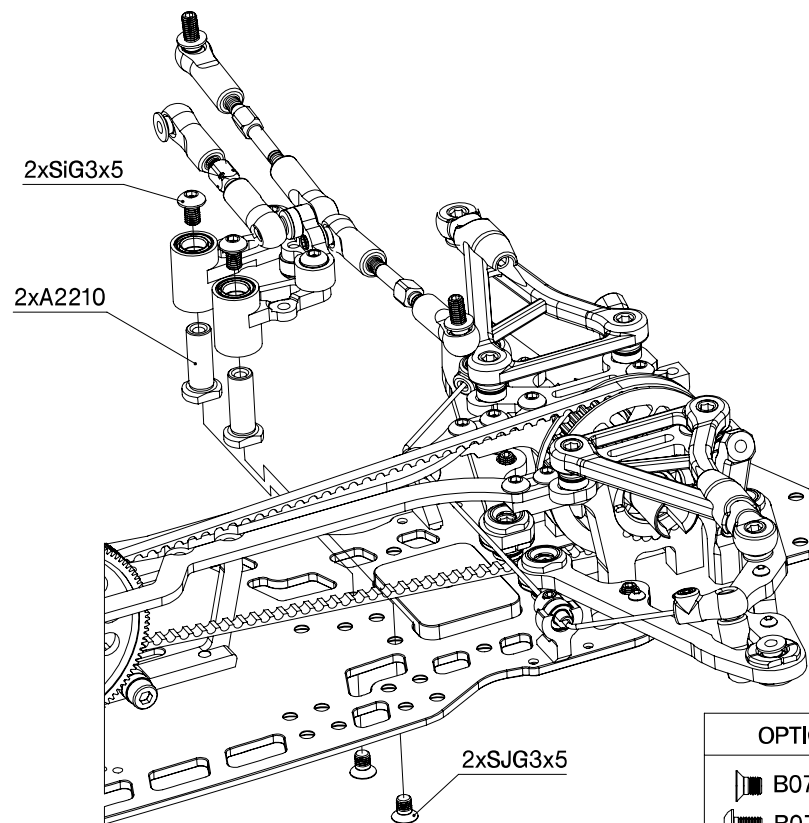
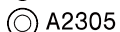
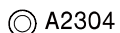
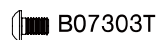

OPTION

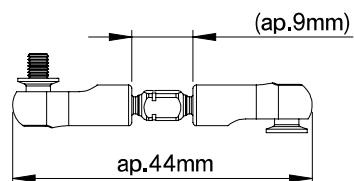

The final length will be a result of steering adjustments. An equal EPA value on your transmitter is the target!

Step 10-1 Kit Bag-A2/D1

FRONT

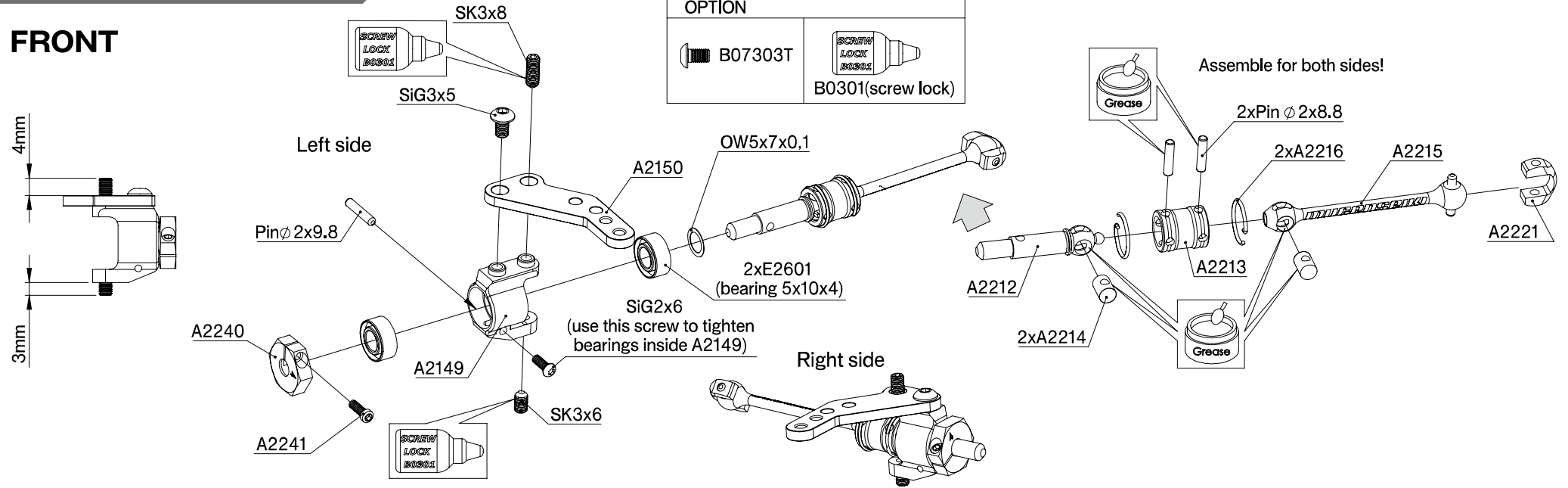

REAR

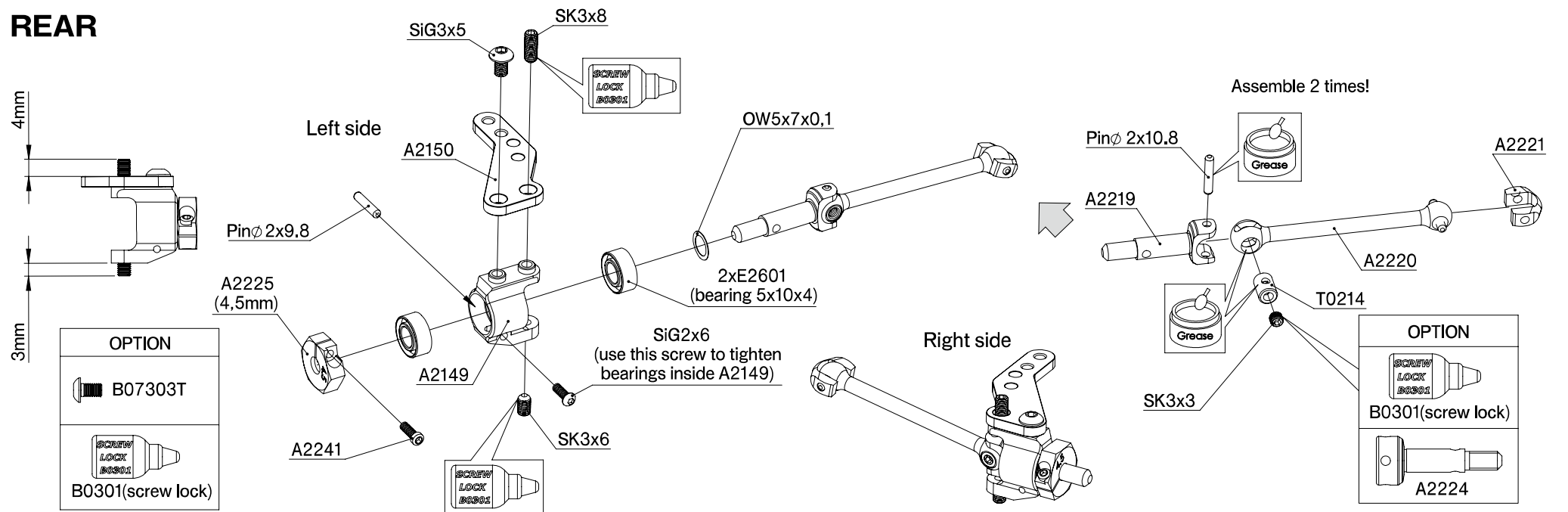

Step 1 1-1 Kit Bag-A2/D1

FRONT

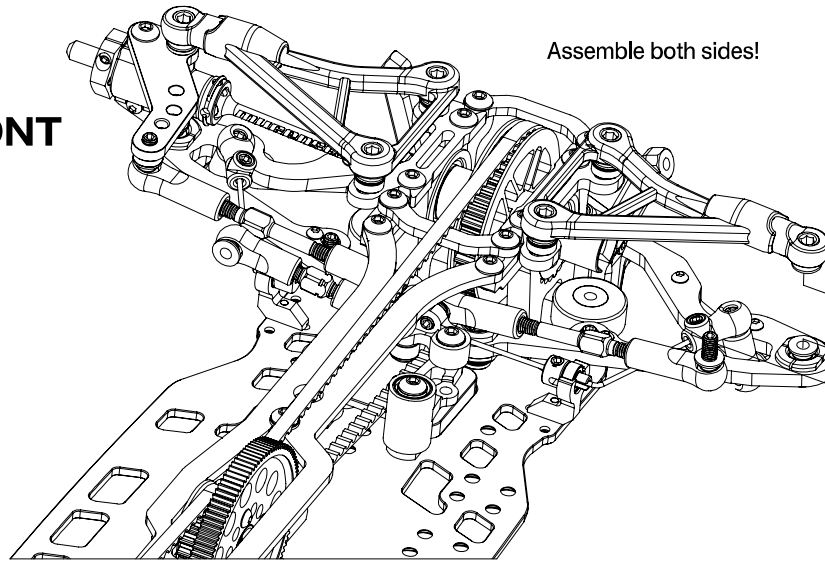

Cutaway view
Shim
A2813
A2150
SK screw
(be sure the SK screw is long enough)

Use shims A2803/A2804/A2811 according to setup recommendation in setup sheet area

"SHIM UPRIGHT"

Use shims A2803/A2804/A2811 according to setup recommendation in setup sheet area

"STEERING ROD POS."

REAR

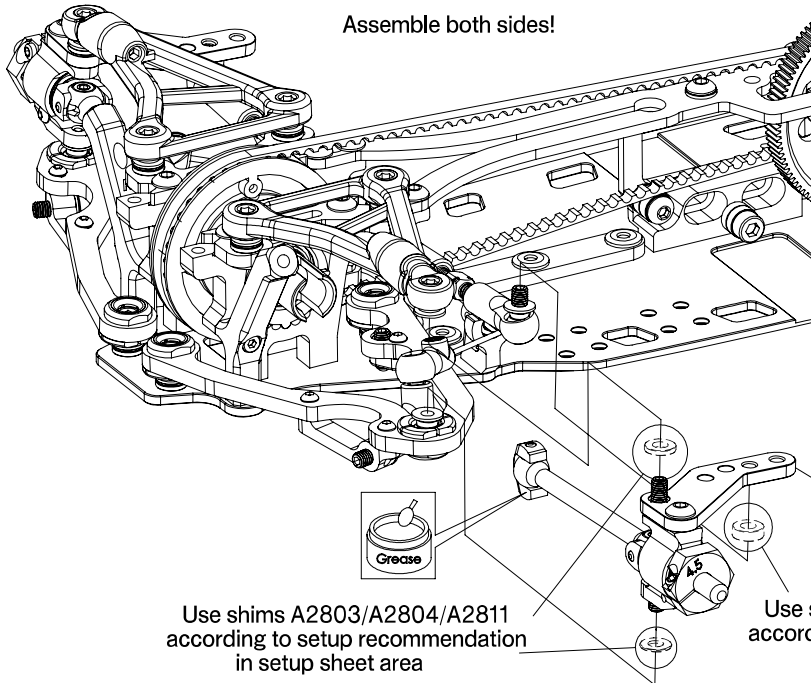

Assemble both sides!

Cutaway view
A2150
Shim
A2813
SK screw
(be sure the SK screw is long enough)

Please find the position to mount the toe rod according to setup recommendation setup sheet area

"REAR TOE ROD POS"

Use shims A2803/A2804/A2811 according to setup recommendation in setup sheet area

"SHIM UPRIGHT"

Use shims A2803/A2804/A2811 according to setup recommendation in setup sheet area

"TOE ROD POS."

FRONT

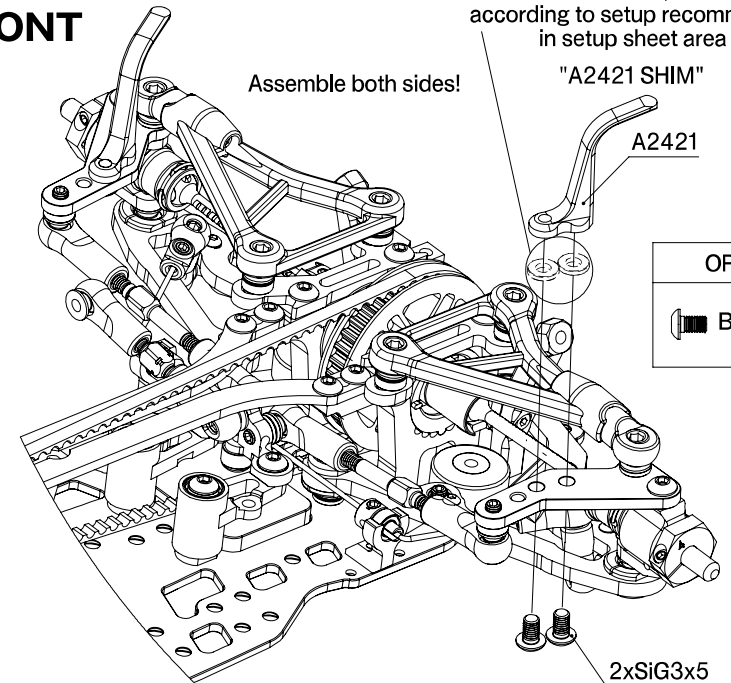

Assemble both sides!

Use shims A2803/A2804/A2811 according to setup recommendation in setup sheet area

"A2421 SHIM"

A2421

OPTION

B07303T

2xSiG3x5

Choose the right screw length in case of using shims between A2421 and A2150!
SiG3x6 (1mm shim) SiG3x8 (2-3mm shim) (screws and shims not included)

Step 13-1 Kit Bag-D1

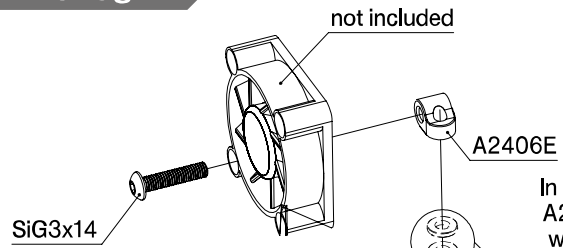

In case you use optional weight A2423 (20g) to equal left/right weight distribution, you need to add shims to raise the height of cooling fan!

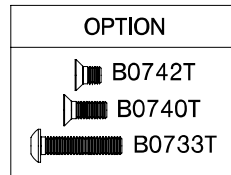
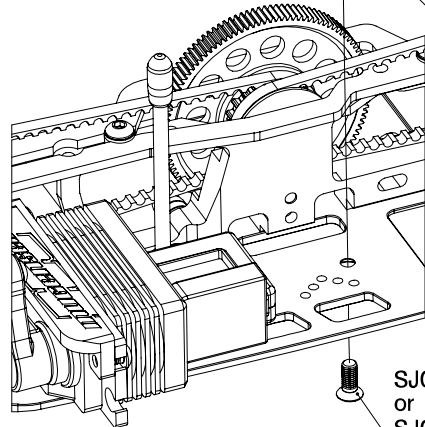

SJG3x8
or
SJG3x6

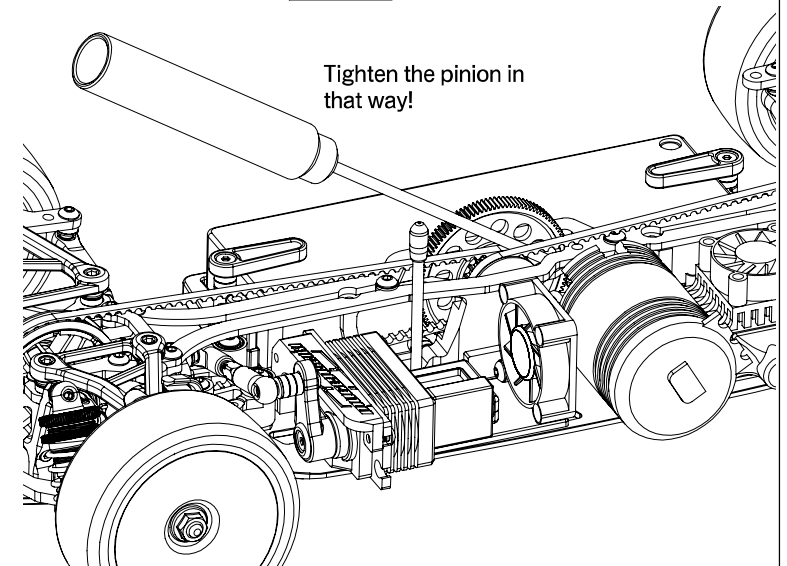
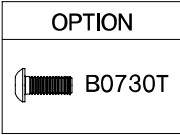
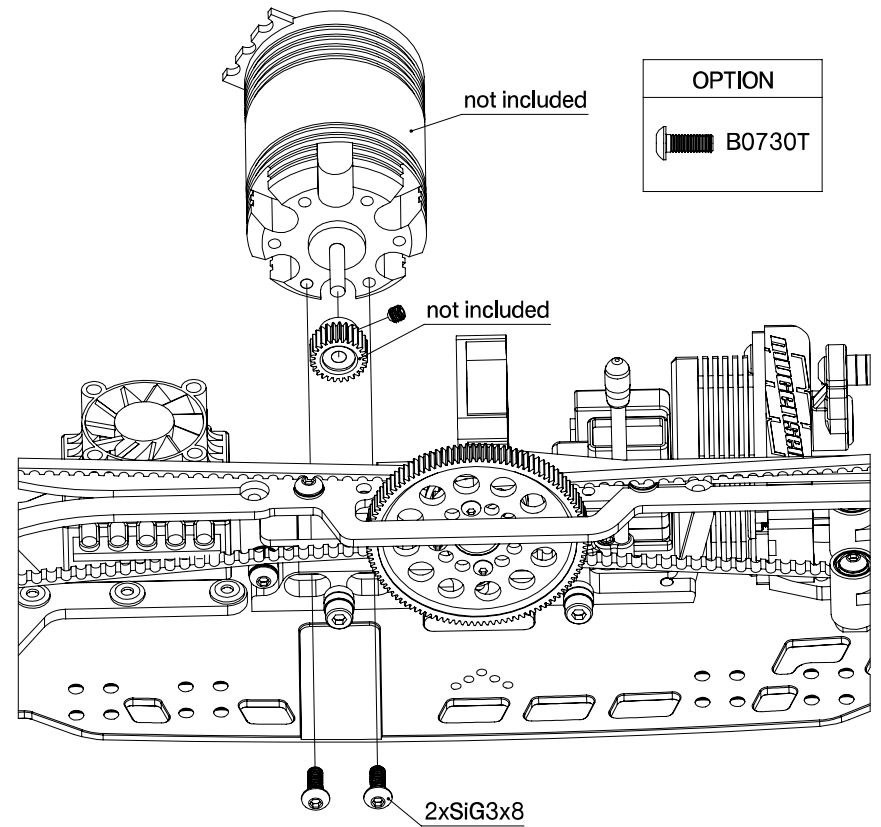
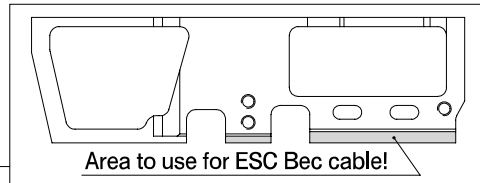
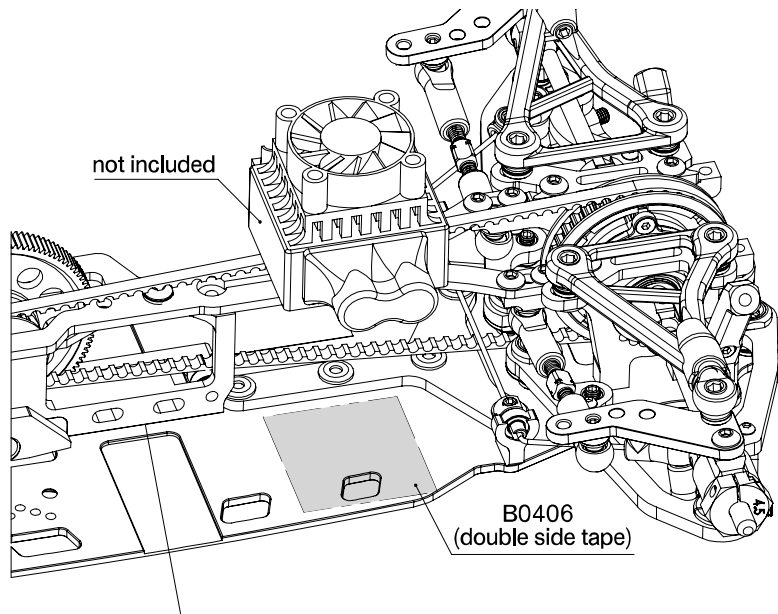

Step 13-2

Kit Bag-A2/D1

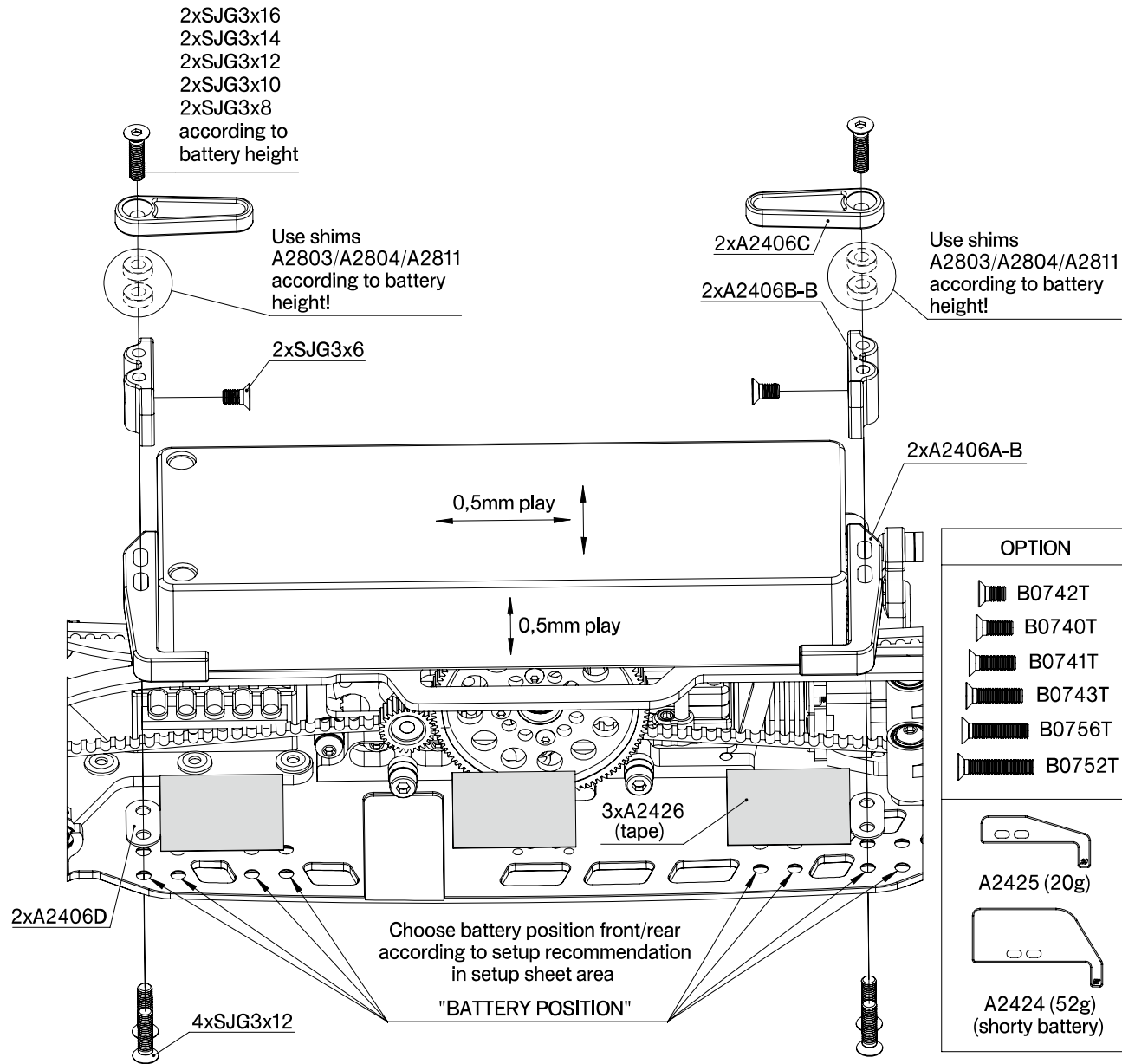

Step 14-1

Kit Bag-E1

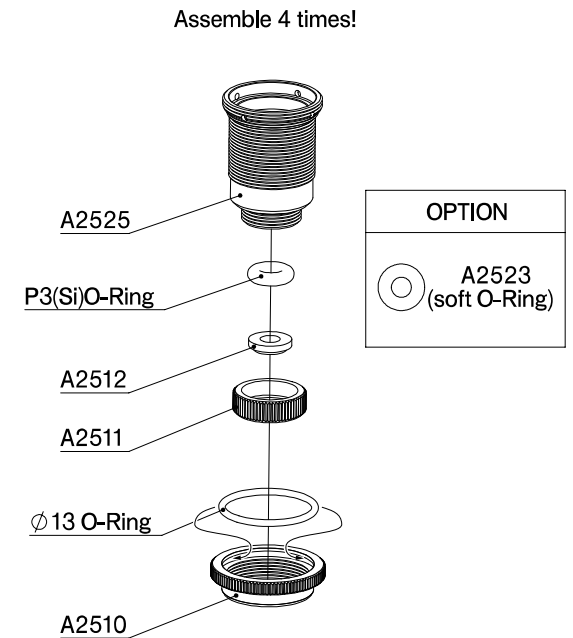
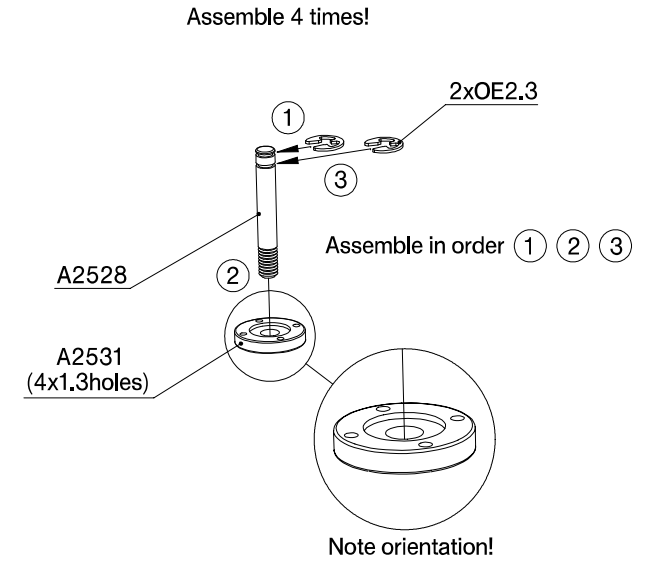

Step 14-2

Kit Bag-A2/E1

B0316Z
(Silicone oil #400)
Use Silicone oil according
to setup recommendation
in setup sheet area
"SHOCK ABSORBERS"

OPTION

- B0314 #300
- B0315 #350
- B0316 #400
- B0332 #450
- B0325 #500

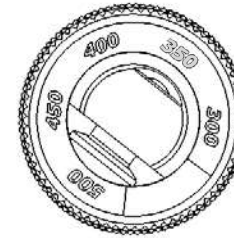

Please note you can
turn the Laser engraving
which shows up oil hardness,
align the hole of ball cup.
So you can recognize which
oil is filled in.

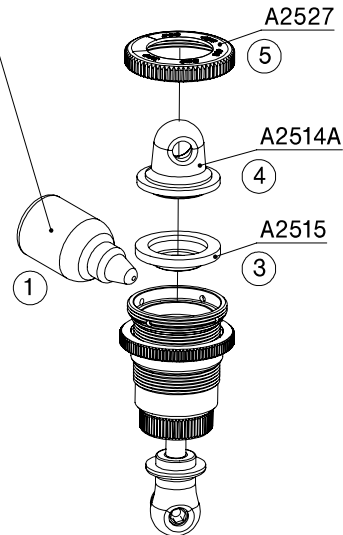
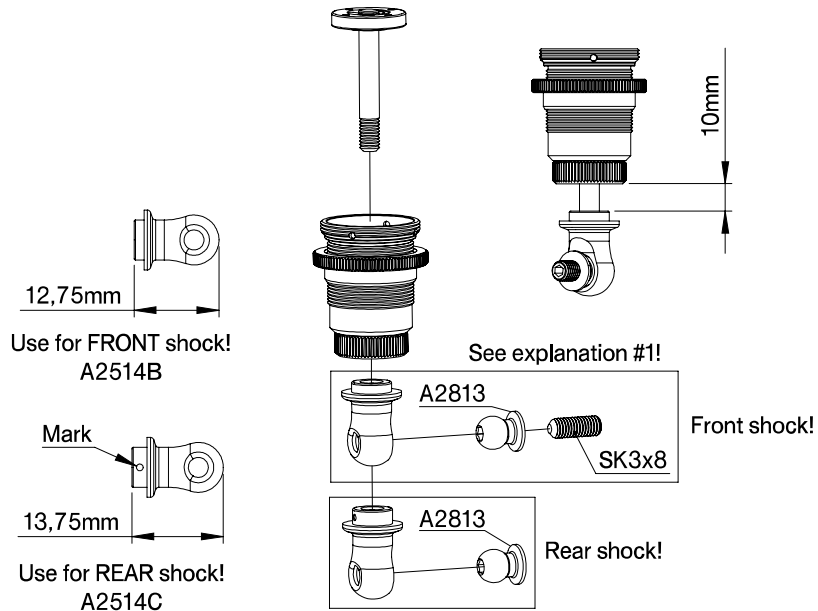

Assemble in order:

- 1 Fill up with silicone oil and let the bubbles come out
- 2 Push the piston upwards until ap. 4mm
- 3 Put A2515 inside the case
- 4 Set A2514A onto the membrane
- 5 Close the shock with the nut A2527

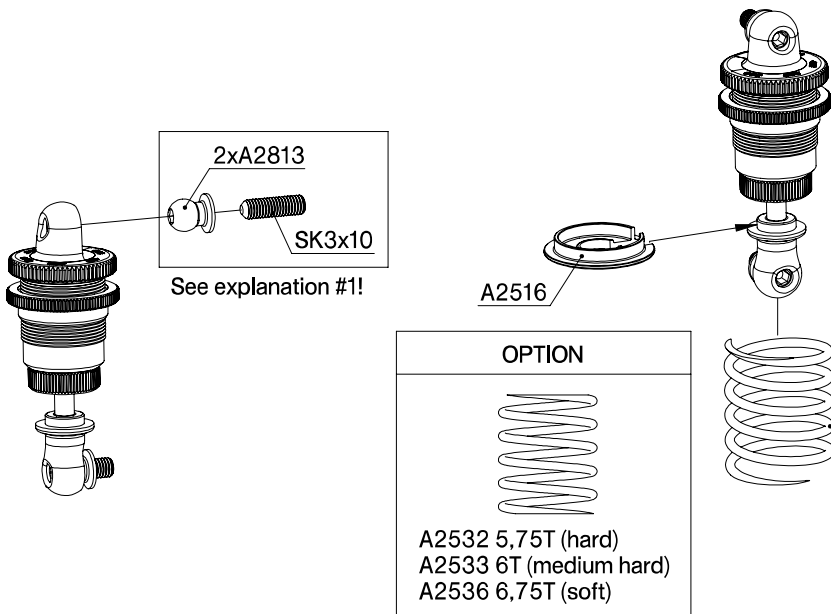
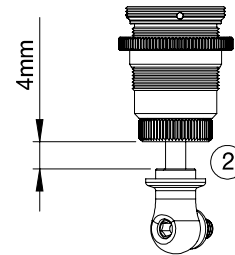

Use springs
according to setup
recommendation
in setup sheet area

"SPRING"

Included in kit:
Front : A2535 6,5T (medium soft) 2pcs.
Rear : A2534 6,25T (medium) 2pcs.

OPTION

- A2532 5,75T (hard)
- A2533 6T (medium hard)
- A2536 6,75T (soft)

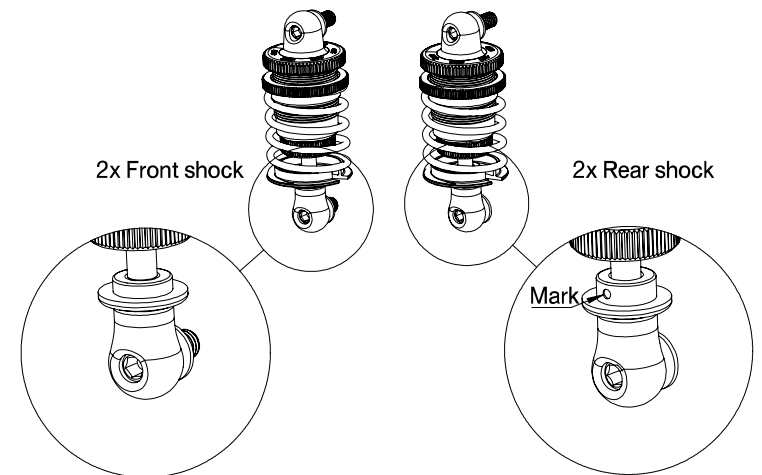

Step 14-3

Kit Bag-E1

FRONT

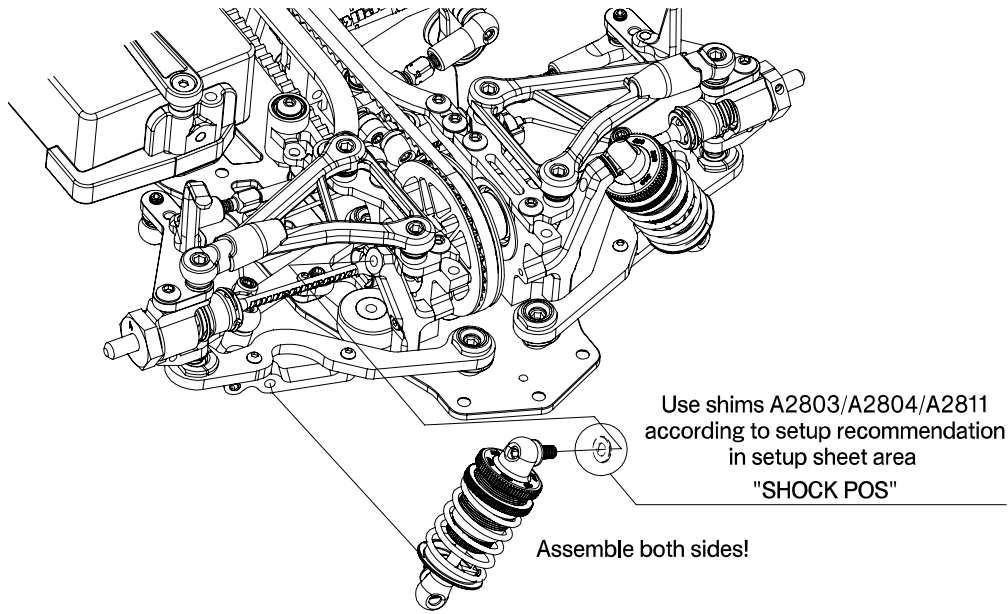

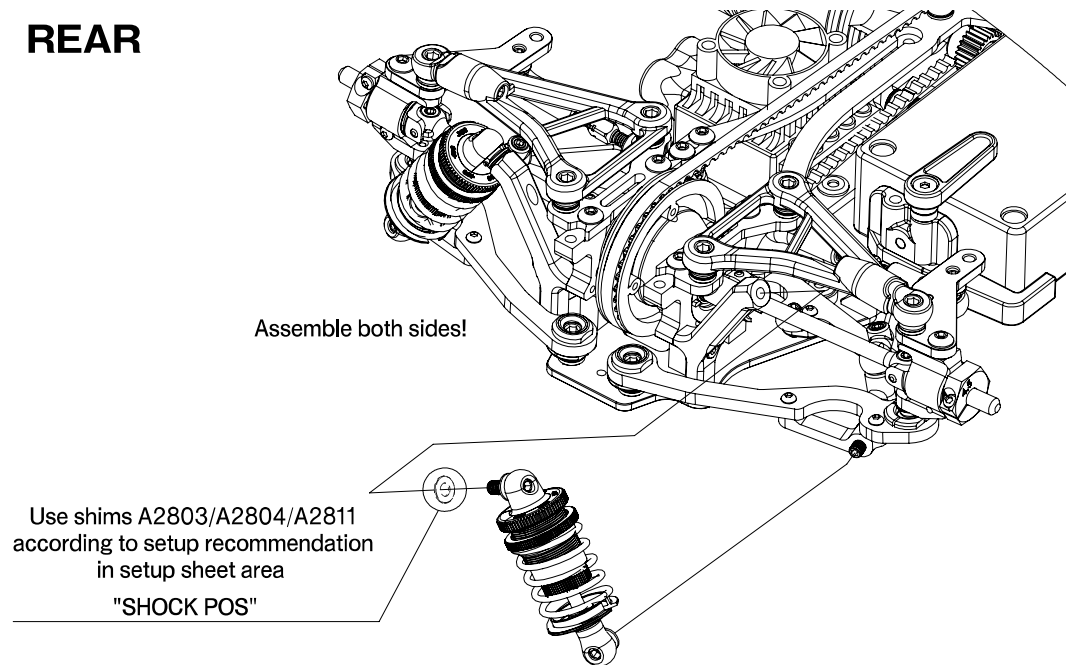

REAR



Step 15-1

Kit Bag-F1

OPTION	
	B0730T
	B0740T

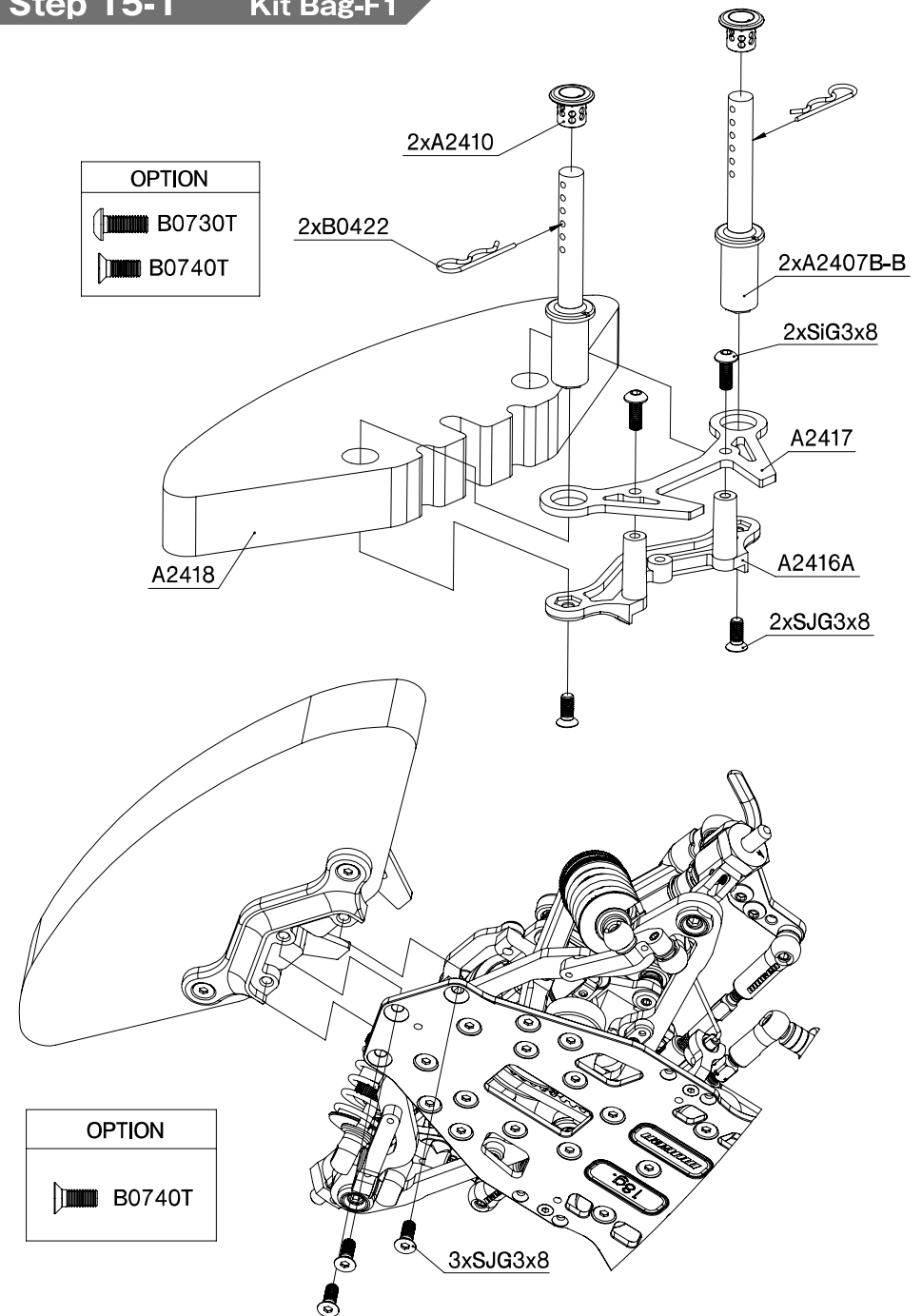

Step 15-2 Kit Bag-F1

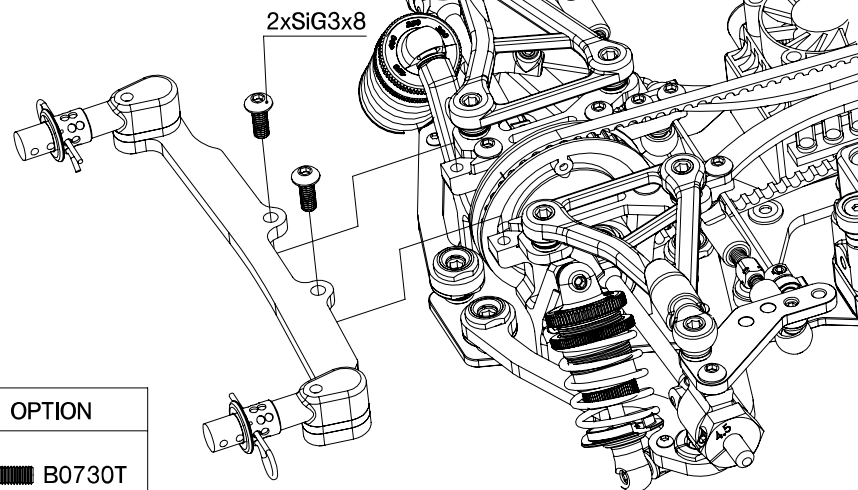
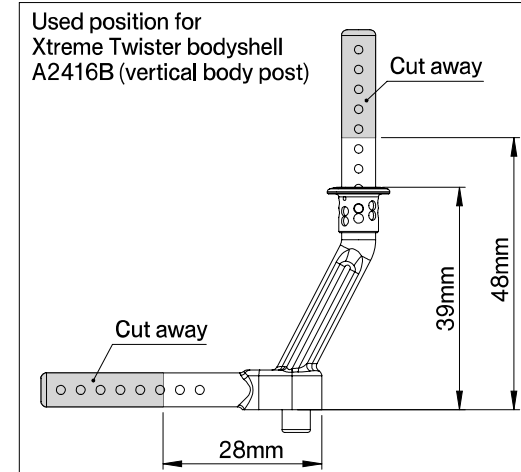
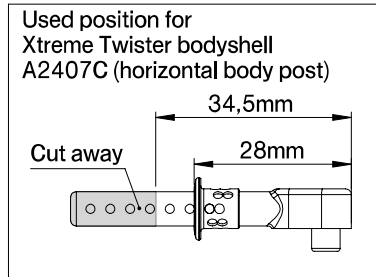
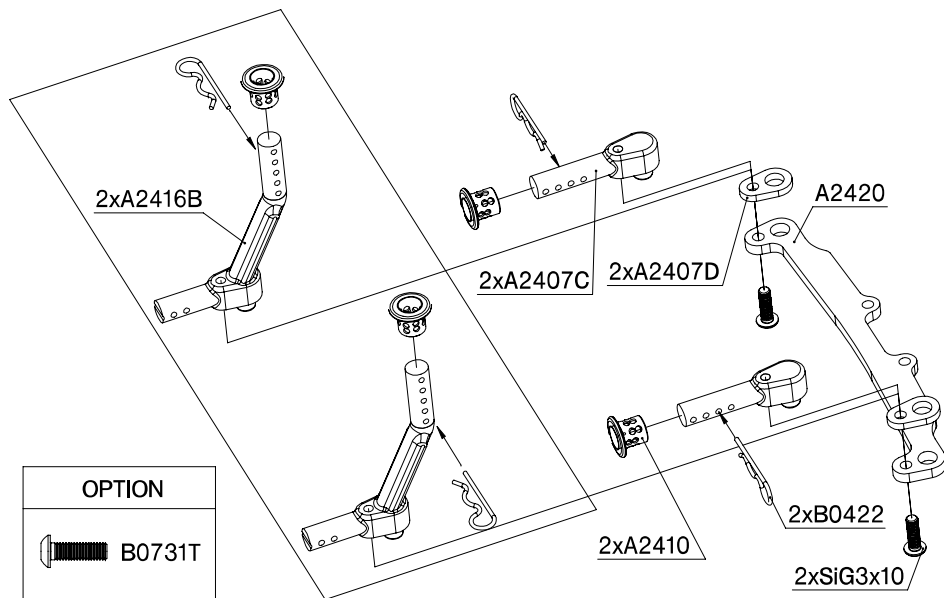

Step 16-1 Kit Bag-A2

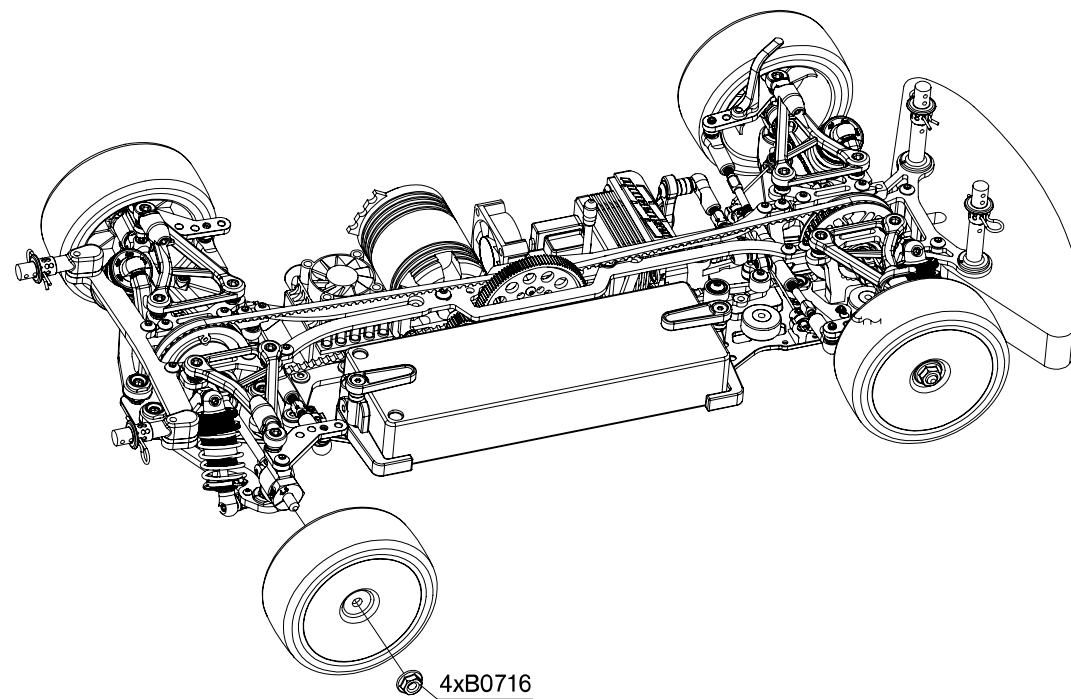

Before / After Operating

*It is very dangerous if you make a mistake in the order of on/off switch on transmitter and model.

Loss of control will result due to the interference of frequency.

Install the charged batteries on the model and connect the battery connectors.

Extend transmitter antenna and turn the power on. Then, turn on the switch of the model (ESC).

Raise the tires off the ground and check if the model is functioning properly.

Make sure the motor is not rotated at the neutral position of throttle.

Check if the steering operates the front tires correctly.

Start operation after checking each part of the model moves properly in accordance with the operation of transmitter.

Always turn off the model (ESC) first, and turn off the transmitter after running.

Always disconnect/remove the batteries when the model is not in use.

Trouble Shooting

PROBLEM	CAUSE	SOLUTION
Model doesn't move	Battery on model is not charged. The wiring is short-circuited. Motor failure. ESC failure. Assembly mistake in rotation part.	Charge it correctly. Insulating and repair the wiring. Repair or exchange the motor. Repair or exchange the ESC. Reassemble it according to the instruction manual.
Model is hard to control	Weak transmitter and/or receiver batteries. Low reception from radio antennas. Servo linkage is not adjusted properly. Assembly mistake in rotation part, wrong adjustment.	Recharge or replace batteries. Fully extend transmitter and receiver antennas. Reassemble it according to the instruction manual. Reassemble it according to the instruction manual.

走行の準備、終了

*送信機および車体側スイッチのON/OFFの順番を間違えると大変危険です。

電波の混信によって車体が暴走する恐れがあります。

十分に充電されたバッテリーを車体に取り付け、コネクタをつなぎます。

送信機のアンテナをのばし、スイッチをONにします。

次に車体（スピードコントローラー）のスイッチをONにします。

車体を台等に載せ、タイヤを浮かせた状態にします。

スロットルのニュートラルの状態でもーターが回転しないことを確認します。

ステアリングが正常に動くか確認します。

送信機の操作を行い、車体各部の動きが正常であることを確認した後、走行を開始してください。

走行終了後、車体（スピードコントローラー）のスイッチをOFFにします。

その後送信機のスイッチをOFFにします。

走行後は必ず車体からバッテリーをはずしておいてください。

Trouble Shooting

車の状態	考えられる原因	直し方
車が全く動かない。	走行用バッテリーが充電されていない。 配線がショートしている。 モーターが故障している。 スピードコントローラーが故障している。 回転部の組立て間違い。	走行用バッテリーを充電する。 ショート箇所を絶縁等、修理する。 モーターを修理もしくは交換する。 スピードコントローラーを修理もしくは交換する。 取扱説明書通りに組立て直す。
車が思いどおり動かない。	車が思いどおり動かない。 送信機、走行用バッテリーが減っている。 電波の送受信状態が良くない。 サーボリンクエッジの調整不足。 回転部の組立て間違い、調整不足。	バッテリーを交換もしくは充電する。 送受信機のアンテナを完全に伸ばす。 取扱説明書通りに組立て直す。 取扱説明書通りに組立て直す。

SAFETY PRECAUTIONS ※Please read carefully before assembling and operating your model.

- This product is high performance radio control model car. Follow the rules and enjoy your drive.
- To enjoy this model to its fullest, prepare other necessary equipments and convenient tools for assembly in advance.
- Improper usage of batteries for radio control model car may not only damage the electronics of the car and/or radio, but can cause excess heat and possibly fire, resulting in serious accidents. Be sure to operate the battery safely.

In order to avoid accidents and personal injury, adhere to following instructions:

Handling of radio control car

- This model car can exceed very high speed, and cannot be stopped quickly.
- Operate your model only on designated areas, race tracks, and other spacious areas.
- Also, be sure to operate the model car safely to avoid serious personal injury, property damage, and unforeseen accidents.

Before assembling

- Before you begin, read the instruction manual thoroughly.
- Read the instruction manual supplied with transmitter, ESC, or motor, and understand how to use beforehand.
- Keep out of the reach of children.
- All tools require careful handling to avoid injury.
- Painting must be done only in well-ventilated area.
- Feel free to contact us if you have any questions.

Check before operations

- Be sure to tight screws, nuts etc. securely and install all parts.
- Make sure whether the moveable part works smoothly.
- Fully charge the batteries of the transmitter and model.
- Turn on the transmitter and then ESC to check if the steering servo and ESC work properly.
With weak batteries, transmission and reception of the radio fall off.
Models may become out of control under such condition, which may cause serious accidents.
- Stop the model car immediately when the electric wave is interrupted and it is not possible to control.

Cautions during operations

- Always fun your car with the body shell mounted.
- Do not put fingers or any objects inside rotating and moving parts (Tire, Shaft, Gear).
- Stop the model car and check the problem immediately when it behaves strangely or it sounds strangely.
- Do NOT operate in.....
 1. Crowded place
 2. Near Children
 3. Near residential districts, schools, and hospitals
 4. Near roads and railroads
 5. Indoors and in limited space
 6. Nighttime and early morning
 7. Place where running of radio control model car is prohibited

Cautions after operations

- Always switch off the speed controller and then transmitter.
The car might be loss of control when it makes a mistake in order.
- Do not touch the moter, ESC, battery because it might be very hot after use.
- Always disconnect/remove the batteries when the model is not in use.
Failure to do so may cause damage to the batteries from excessive discharge and leaking.
- Do care after running to maintain performance, to notice the damage and the wear, to avoid further trouble.
- Do not store the model car in hot or humid conditions, or in direct sunlight.

Handling of battery

- Be careful of handling of the battery.
- Properly connect plugs firmly.
- Never reverse connection nor disassemble batteries.
- When using rechargeable batteries, carefully read and follow the instructions supplied with the battery and charger unit.

安全のための注意事項 ※組み立て、走行前に必ずお読みください。

- ・この商品は、高性能なR/Cカーです。ルールを守って楽しく走行させてください。
- ・この商品を楽しむために、商品以外に必要な物や組み立てに便利な工具など事前に用意しておきましょう。
- ・R/Cカーに使用する電池は使い方を誤ると大きな電流が流れ、コードが焼けたり発火する危険があります。取扱には十分注意してください。

思わぬ事故やケガなどの危険防止のため、次の事項を必ずお守りください。

R/Cカーの取り扱いについて

このR/Cカーは非常に速いスピードで走行します。走行させる場合は安全で人の迷惑にならない広い場所で走行させてください。
また、人にケガをさせたり、物を壊したり、思わぬ事故が起こらないように十分注意して走行を楽しみください。

組み立て前に

- ・組み立て前に必ずキットの説明書を最後までお読みください。
- ・使用するプロポ、スピードコントローラーやモーター等に付属している説明書をよく読み、事前に使用方法を理解しておいてください。
- ・小さなお子様のいる場所で作業しないでください。
- ・カッターやニッパー、ハサミなどの工具の取り扱いには十分注意してください。
- ・塗装する場合は室内の換気に十分注意して作業をおこなってください。
- ・製品の事で不明な点がございましたらお気軽に弊社までお問い合わせください。

走行前の点検

- ・ネジ、ナットの緩みや締め忘れ、部品の取り付け忘れのないことを確認してください。
- ・可動部分がスムーズに動くことを確認してください。
- ・送信機バッテリー、車体用バッテリーが十分に充電されていることを確認してください。
- ・送信機、スピードコントローラーの順にスイッチを入れたステアリングサーボ、スピードコントローラーが正常に動くことを確認してください。
バッテリーの要領が少ないと車をコントロールすることが出来なくなり、暴走や衝突の原因になり危険です。
- ・電波が混信しコントロールができない場合は、すぐに走行を中止してください。

走行上の注意

- ・走行時は必ずボディを装着してください。
- ・回転している部分（タイヤ、シャフト、ギヤ）に触れたり、異物を入れないでください。
- ・走行させてはいけない場所……………1. 人の多い所。
2. 小さな子供の近く。
3. 住宅、学校、病院の近く。
4. 道路、線路の近く。
5. 室内、狭い場所。
6. 夜間や早朝は走行させない。
7. その他、R/Cカーの走行が禁止されている場所。

走行後の注意

- ・必ずスピードコントローラーのスイッチをOFFにしてから、送信機のスイッチをOFFにしてください。順番を間違えると車が暴走する恐れがあります。
- ・走行後のモーター、スピードコントローラーやバッテリーは熱くなっているので、直接手で触れないでください。ヤケドの恐れがあります。
- ・走行させない場合は送信機バッテリー、車体用バッテリーは取り外してください。ご走行やバッテリーの過放電、発熱や液漏れなどの恐れがあります。
- ・走行後は性能を保つ為や破損部分、磨耗部分に気付くためにも車のメンテナンス（点検、整備）を行なってください。メンテナンスを怠るとトラブルが発生しやすくなります。
- ・車の保管は温度の高くなる場所や湿度の高くなる場所は避けてください。

バッテリーの取り扱い

- ・バッテリーの取扱いは十分注意してください。
- ・コードの接続はコネクターをしっかりと押し込んで、確実につないでください。
- ・バッテリーの逆接続、分解は絶対にしないでください。
- ・充電はバッテリーや充電器の説明書に従い、正しい方法で行なってください。



MUGEN SEIKI CO., LTD.

1395 Takane-cho, Funabashi, Chiba
274-0817, Japan

E-mail: support@mugenseiki.com
www.mugenseiki.co.jp
www.mugenseiki.com

MUGEN SEIKI RACING LTD.

20525 Crescent Bay Drive
Lake Forest, CA 92630, USA

E-mail: support@mugenracing.com
www.mugenracing.com

MSE MUGEN SEIKI Europe Vertriebs GmbH

Auf'm Wasserkamp 3,
D-45881 Gelsenkirchen, Germany

E-mail: info@mugen.eu
www.mugen.eu