

# MTC2R SETUP SHEET

NAME: \_\_\_\_\_ DATE: \_\_\_\_\_

TRACK: \_\_\_\_\_ RACE: \_\_\_\_\_

TRACK SURFACE: CARPET  ASPHALT

LAYOUT: TECHNICAL  MIXED  FAST

TRACTION: LOW  MEDIUM  HIGH

ELECTRONICS

SERVO: \_\_\_\_\_ ESC: \_\_\_\_\_

BATTERY: \_\_\_\_\_ MOTOR/TIMING: \_\_\_\_\_

NOTES: \_\_\_\_\_

TIRES

BRAND/TYPE F/R: \_\_\_\_\_

ADDITIVE F/R: \_\_\_\_\_

ADDITIVE TIMING F/R: \_\_\_\_\_

WARMER° F/R: \_\_\_\_\_

TRANSMISSION

PINION: \_\_\_\_\_ SPUR:  A2248D(Alu):

DIFF OIL CST: \_\_\_\_\_ OIL WEIGHT (qty.): \_\_\_\_\_

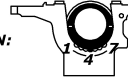
BELT TENSION:  FRONT: 1 2 3 4 5 6 7 REAR: 1 2 3 4 5 6 7

SHOCK'S FRONT: \_\_\_\_\_ REAR: \_\_\_\_\_

SHOCK CASE: \_\_\_\_\_

PISTON: \_\_\_\_\_

OIL: \_\_\_\_\_

SPRING: \_\_\_\_\_

LENGTH: \_\_\_\_\_

ANTI ROLL BAR FRONT: \_\_\_\_\_ REAR: \_\_\_\_\_

OPTIONAL WEIGHT

A2423  A2424  A2425  A2704  A2705

BODYSHELL

TYPE: \_\_\_\_\_ WING TYPE: \_\_\_\_\_

WING POS: \_\_\_\_\_ OVERALL WEIGHT: \_\_\_\_\_

STIFFENER:

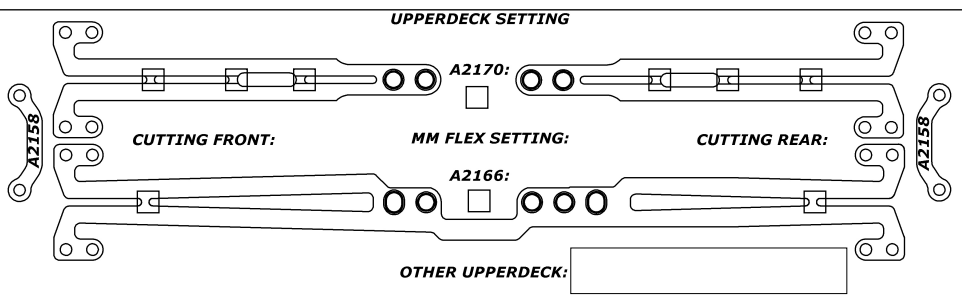
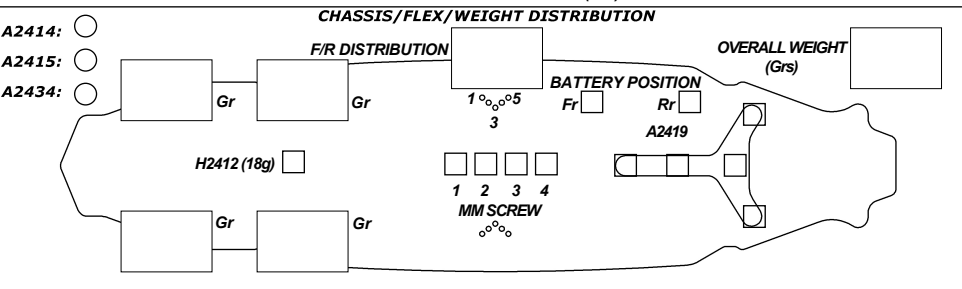
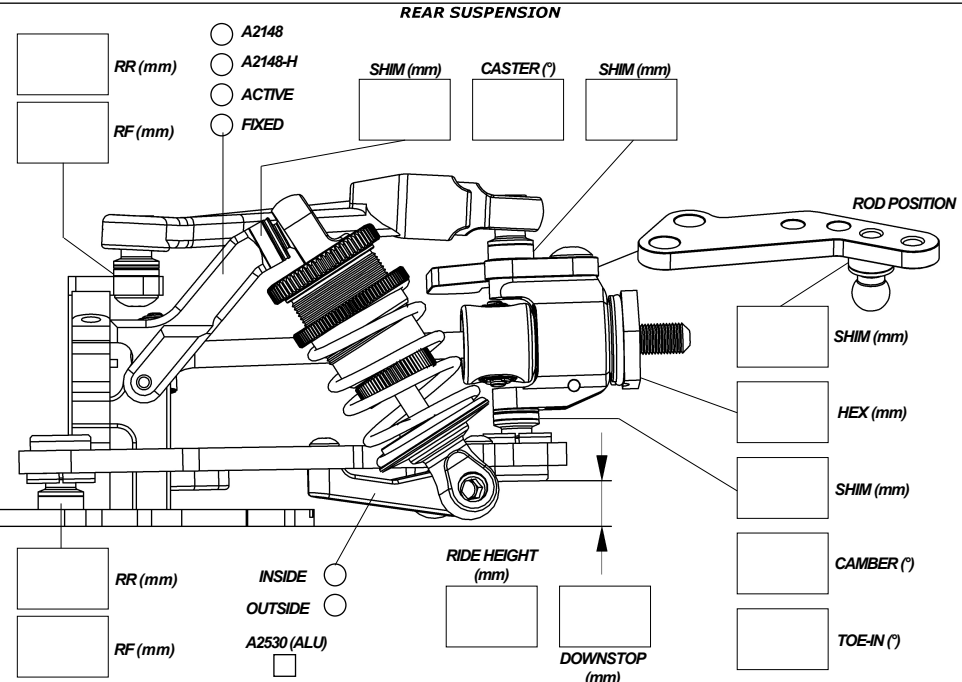
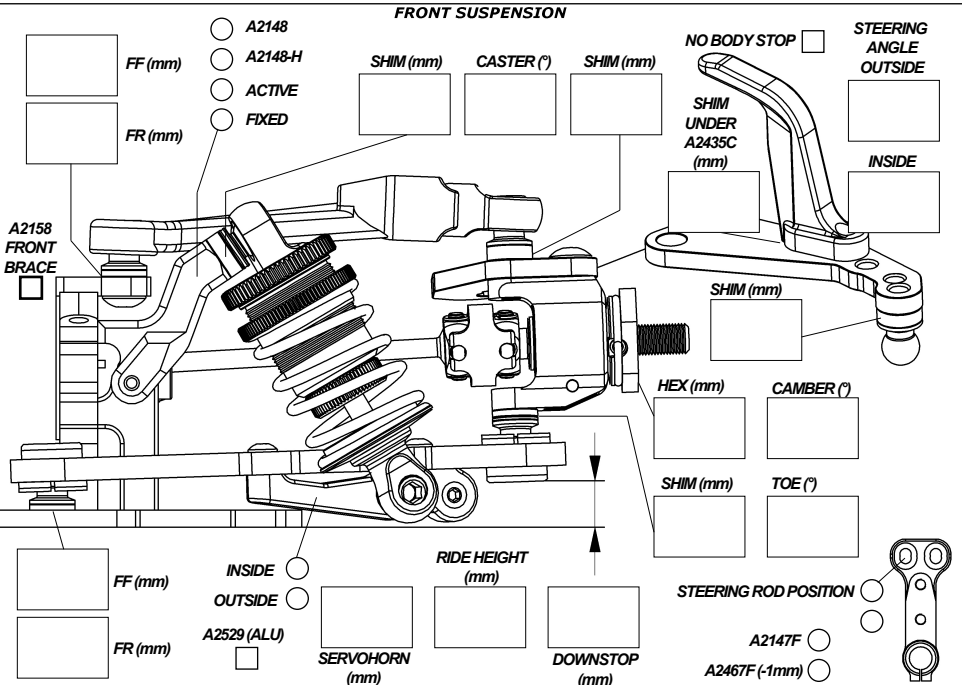
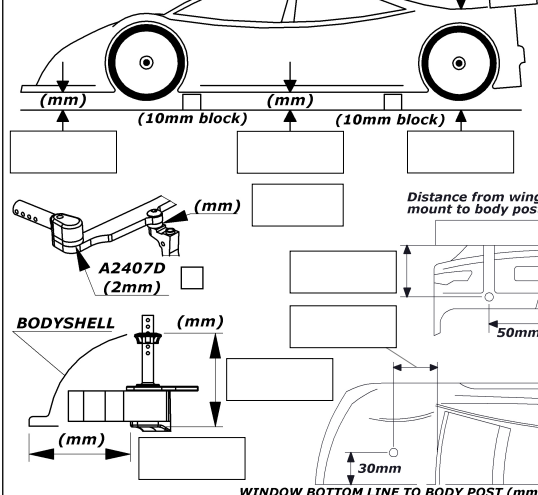

COMMENTS: \_\_\_\_\_