

# SETUPSHEET

VER:1002-1 **MTC2R**

|                |  |
|----------------|--|
| NAME:          | DATE:  |
| TRACK:         | RACE:  |
| TRACK SURFACE: | CARPET <input type="radio"/> ASPHALT <input type="radio"/>                             |
| LAYOUT:        | TECHNICAL <input type="radio"/> MIXED <input type="radio"/> FAST <input type="radio"/> |
| TRACTION:      | LOW <input type="radio"/> MEDIUM <input type="radio"/> HIGH <input type="radio"/>      |
| ELECTRONICS    |  |
| SERVO:         | ESC:   |
| BATTERY:       | MOTOR/TIMING:  |
| NOTES:         |  |

|                      |  |
|----------------------|--|
| TIRES                |  |
| BRAND/TYPE F/R:      |  |
| ADDITIVE F/R:        |  |
| ADDITIVE TIMING F/R: |  |

|               |  |
|---------------|--|
| WARMER° F/R:  |  |
| TRANSMISSION  |  |
| PINION:       | SPUR: <input type="checkbox"/> A2248D(Alu): <input type="checkbox"/> |
| DIFF OIL CST: | OIL WEIGHT (qty.):   |
| BELT TENSION: | FRONT: 1 2 3 4 5 6 7 REAR: 1 2 3 4 5 6 7                             |

|               |        |       |
|---------------|--------|-------|
| SHOCK'S       | FRONT: | REAR: |
| SHOCK CASE:   |        |       |
| PISTON:       |        |       |
| OIL:          |        |       |
| SPRING:       |        |       |
| LENGTH:       |        |       |
| ANTI ROLL BAR | FRONT: | REAR: |

|                                |                                |                                |                                |                                |
|--------------------------------|--------------------------------|--------------------------------|--------------------------------|--------------------------------|
| OPTIONAL WEIGHT                |                                |                                |                                |                                |
| A2423 <input type="checkbox"/> | A2424 <input type="checkbox"/> | A2425 <input type="checkbox"/> | A2704 <input type="checkbox"/> | A2705 <input type="checkbox"/> |

|           |                 |
|-----------|-----------------|
| BODYSHELL |                 |
| TYPE:     | WING TYPE:      |
| WING POS: | OVERALL WEIGHT: |

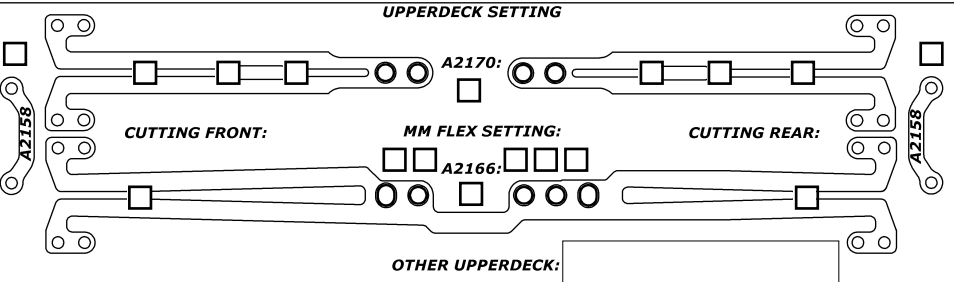
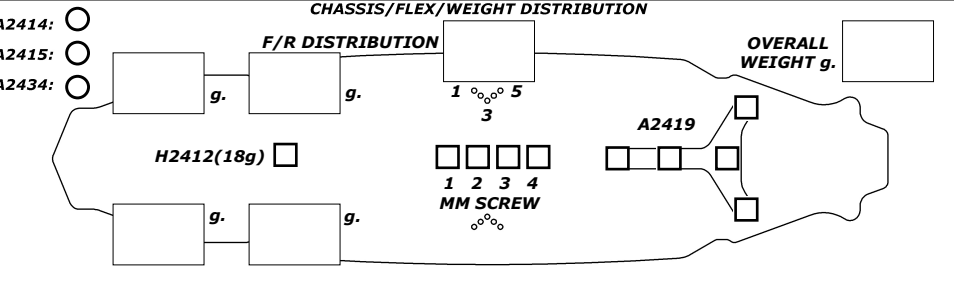
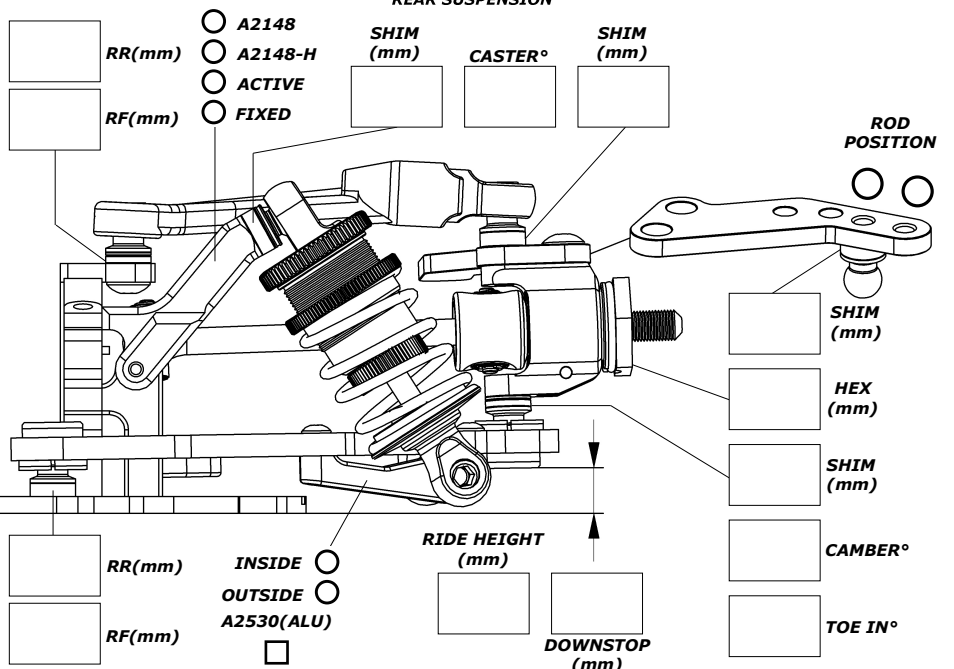
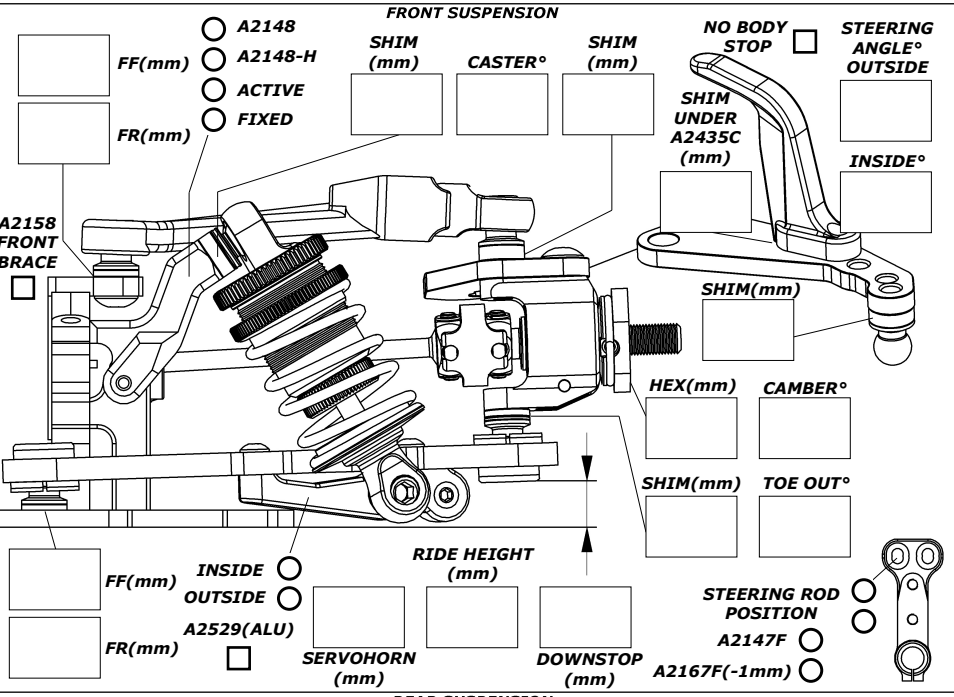
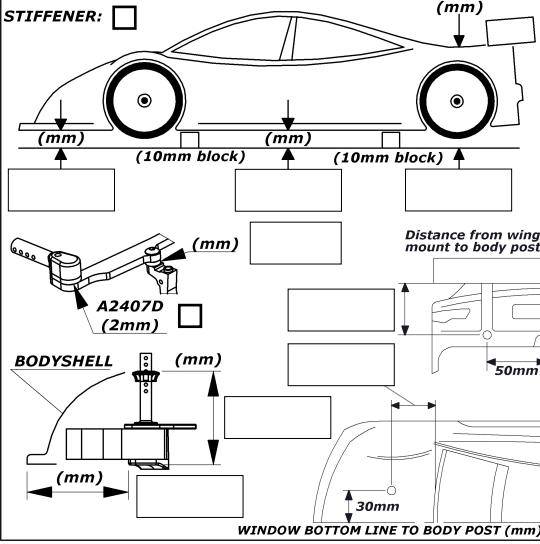

COMMENTS: